

Technical-Description

CHIP-Sensing NTC-Thermister Size 0603

Features

- SMD type suitable for high density mounting
- Series of B constant for various applications
- Excellent solder ability

Applications

- Telecommunications equipment such as cellular phone, automobile phone, etc.
- Office automation such as printer, facsimile, word processor, etc.
- Battery, CPU temperature protection.

Technical Dimensions

Size	0603
Size Code	1608
L(mm)	1,6 ±0,15
W(mm)	0,8 ±0,15
T(mm)	0,8 ±0,15
a(mm)	0,30 ±0,2

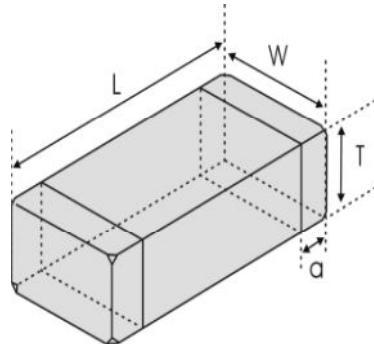

Technical Specifications

Zero Power Resistance Range (KΩ)	100
Zero Power Resistance Range Code	104
Tolerance (%)	±1%
Tolerance Order Code	F
Resistance B Constant (25~50°C)	4250
B Constant Value (K) (25~50°C)	4250K
Tolerance of B Constant (%)	±3%
Tolerance Order Code of B-Constant	H
Thermal Time Constant (sec)	<5 sec.
Dissipation Factor (mW/°C)	1,0
Rated Electric Power (mW)	100
Max. Permissible Operating Current (25°C (mA)	0,1
Operating- Temperature Range (°C)	-40°C ~ +125°C

Packing	Tape/Reel
Packing Code	T/R
Quantity of Reel	4000

DRW:	Lexua	CHKD	Wilson	MATL:	ChuChu	DATE	30.03.2023
APPD:	Jimmy			FINISH	Josy	Sheet	1 from 3

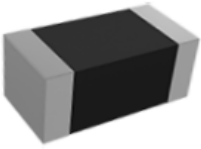

CHIP-Sensing NTC-Thermister Size 0603

Typical Electrical Characteristics

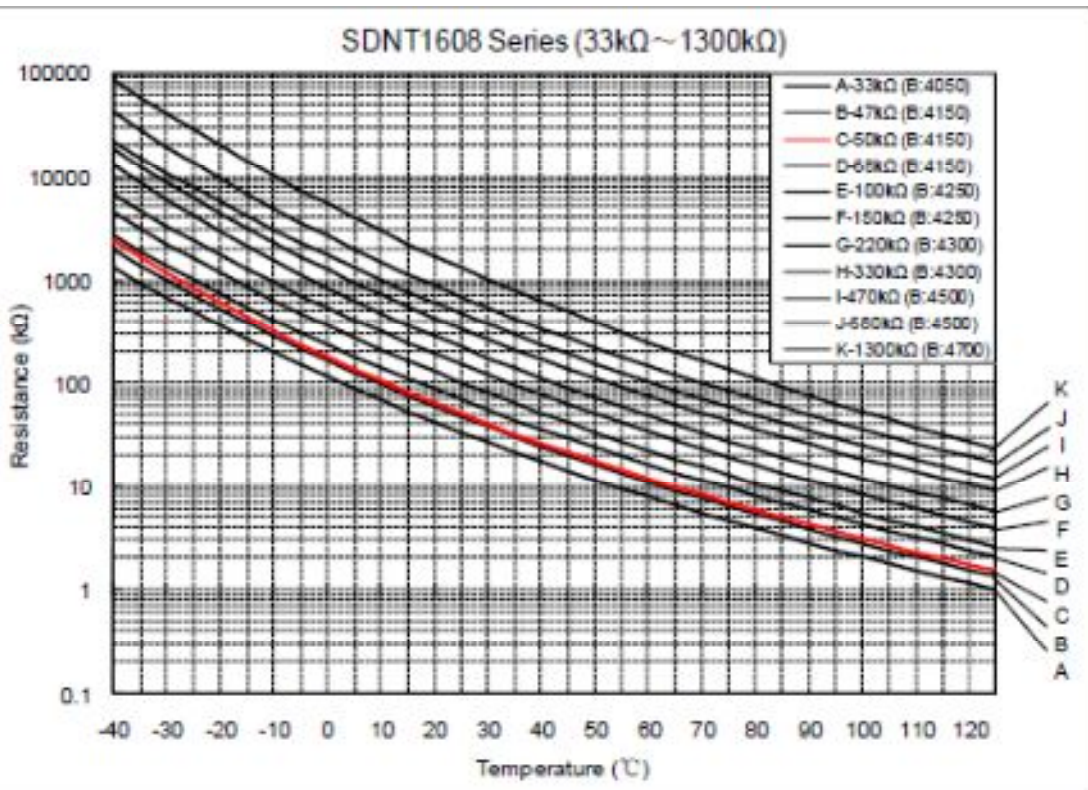
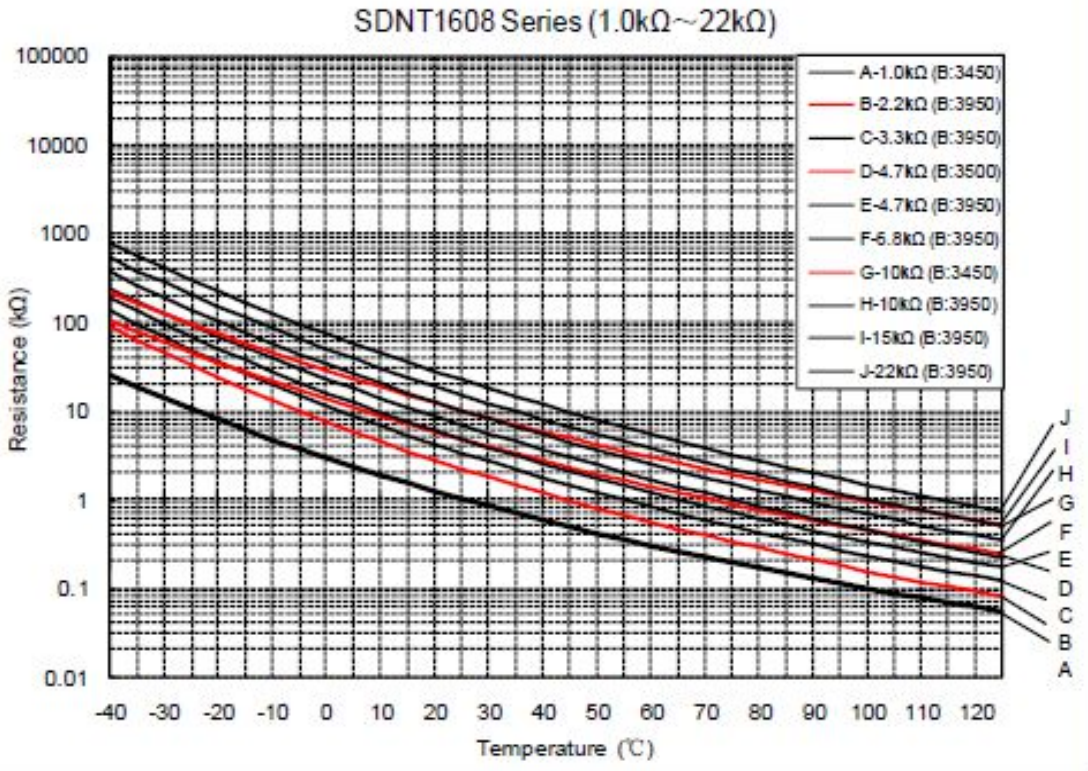

DRW:	Lexua	CHKD	Wilson	MATL:	ChuChu	DATE	30.03.2023
APPD:	Jimmy			FINISH	Josy	Sheet	2 from 3

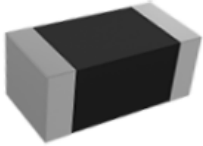

CHIP-Sensing NTC-Thermister Size 0603

Ordering Informations:

Serie-No. - Size - Range	ROHS	Packing	Quantity of Reel
X54004-1608X104F4250H	R	T/R	4000

Serie -	1608	X	104	F	4250	H		
Serie	Size	Intern Code	Range	Tolerance	B-Constant	Tolerance of B-Constant	R= ROHS	T/R= Tape/Reel
							N= NON ROHS	BU= Bulk

Soldering Information

Lead Solder Performance

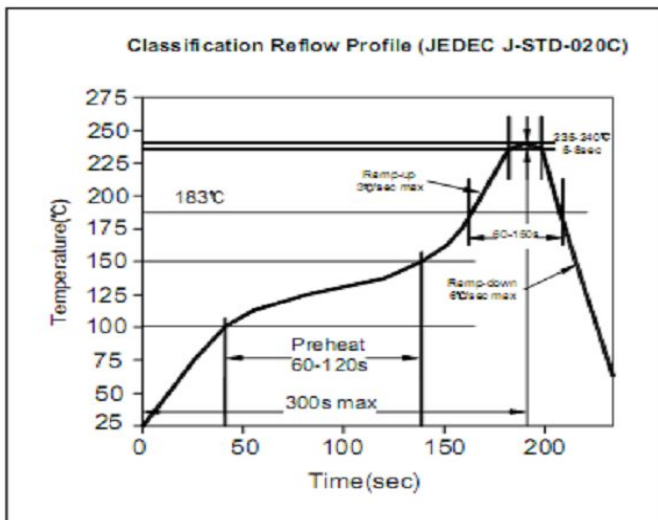

Lead free Solder Performance

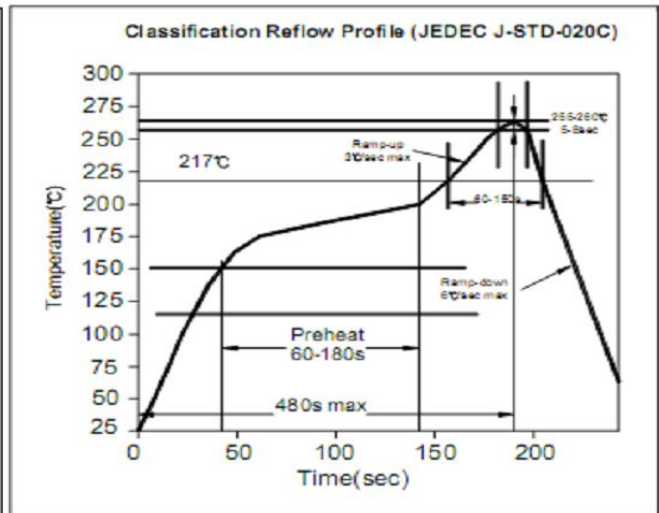

DRW:	Lexua	CHKD	Wilson	MATL:	ChuChu	DATE	30.03.2023
APPD:	Jimmy			FINISH	Josy	Sheet	3 from 3

Copyright by S.Tiede