

EDCON-COMPONENTS



SPECIFICATION:

Voltage Rating:	42V
Current Rating:	100mA
Contact Resistance:	≤100mΩ MAX.
Insulation Resistance:	≥ 100MΩ MIN.
Operating Force:	250gf max
Lifetime Cycles:	20000 cycles
Operating Temperature:	.-25°C to +85°C
Solder Condition:	Reflow Soldering :10s/260°C
	Iron Soldering: 4s/350°C
	Wave Soldering: 5s/280°C

P.C.B Layout

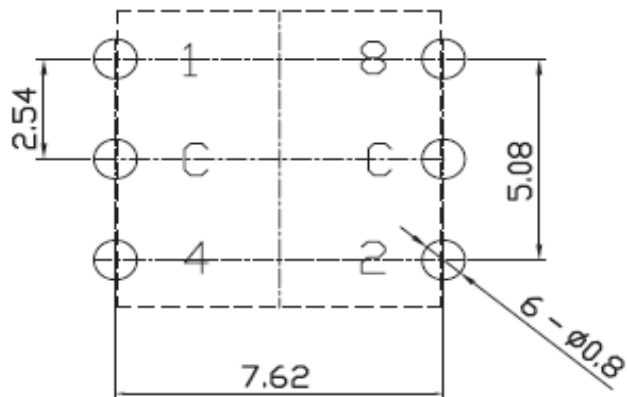

Drawing

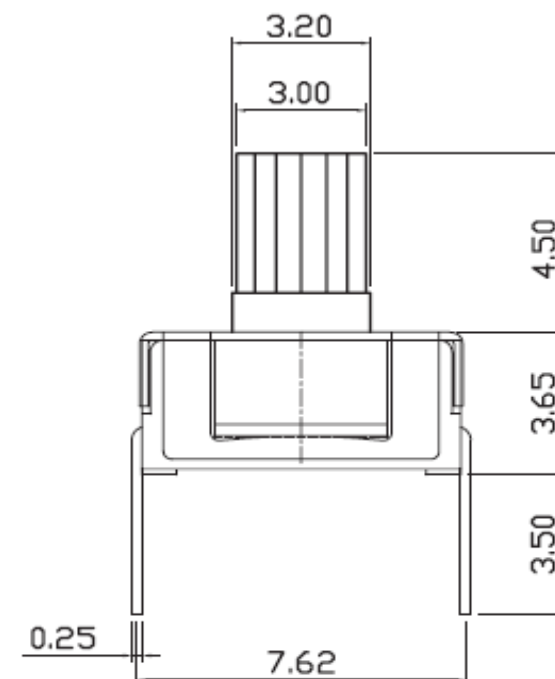
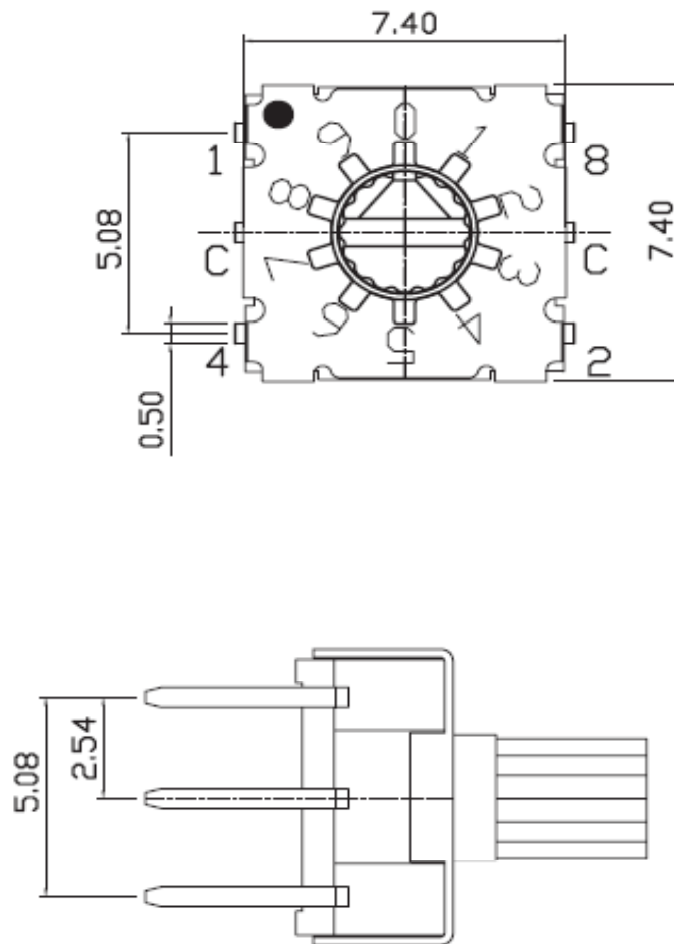

Rotary BCD-Switch
7,4x7,4mm

Part No.: **Q27043**

Customer:

DRW:	Jason	CHKD	Wilson	MATL:	Wilson	TOLERANCE	Mason	DATE	31.07.2021
APPD:	Schumi			FINISH	Jamy		Sheet No.		1 from 2

EDCON-COMPONENTS



Ordering Informations

Serie	Total height w. Body	Special function	Special function	ROHS	Packing				
Q27043	10R	N	N	R	TU				

10R = 10Pos. Real Code	N = No Special function	N = No Special function	N = non ROHS	BU = Bulk Ware
16R = 16Pos. Real Code			R = ROHS conform	TY = Tray Packing
				TR102 = Tape/Reel Packing 1000PCS

		Real Coded				
		C	1	2	4	8
10 P o s i t i o n	0	●				
	1	●	●			
	2	●		●		
	3	●	●	●		
	4	●			●	
	5	●	●		●	
	6	●		●	●	
	7	●	●	●	●	
	8	●				●
	9	●	●			●
16 P o s i t i o n	A	●		●		●
	B	●	●	●		●
	C	●			●	●
	D	●	●		●	●
	E	●		●	●	●
	F	●	●	●	●	●

Rotary BCD-Switch 7,4x7,4mm	
Part No.:	Q27043
Customer:	

DRW:	Jason	CHKD	Wilson	MATL:	Wilson	TOLERANCE	Mason	DATE	31.07.2021
APPD:	Schumi			FINISH	Jamy		Sheet No.		2 from 2