

DATA SHEET

D-SUB / Stamped Pin / Right-Angle 7,2mm US-Norm / Z-Shape / Fixed Hex-Screw/ Male

Serie: T24E4001

**D-SUB / Stamped Pin / Right-Angle
7,2mm US-Norm / Z-Shape / Fixed Hex-
Screw/ Male**

Serie No.: T24E4001

DRW:	Jason	CHKD	Wilson	MATL:	Wilson	TOLERANCE	Mason	DATE	07.02.2023	Customer:
APPD:	Schumi			FINISH	Jamy		Sheet No.	1 from 5		

EDCON-COMPONENTS

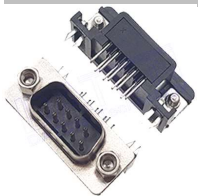

Technical Informations

Material	
Insulator	PBT +30% GF rated UL-94-V0
Contact:	Brass
Shell:	Steel
Rivet / Boardlock::	Copper Alloy
Contact Plating:	Gold Flash over 40µ Nickel on all area, Contact area see Ordering
Electrical	
Opening Voltage:	250VAC max.
Current Rating:	3,0A max.
Contact Resistance:	15m Ω max.
Insulation Resistance:	3000M Ω min. @ 500VDC
Dielectric withstanding Voltage:	1000VAC 1 Minute
Mechanical:	
Operating Temperature Range:	.-55°C to + 105°C

Technical Dimensions (mm)

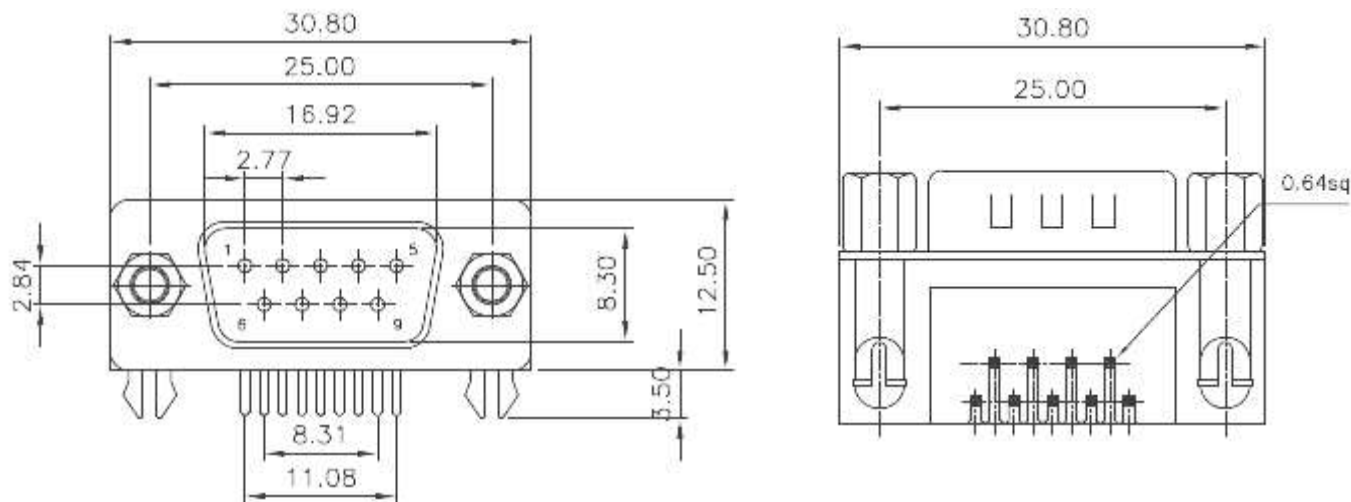

Tolerances unless otherwise specified (mm)

X	X.X	X.XX	X.XXX	Angle					
±0,5	±0,3	±0,2	±	±5°					
DRW:	Jason	CHKD	Wilson	MATL:	Wilson	TOLERANCE	Mason	DATE	07.02.2023
APPD:	Schumi	182AE15MGPFEA3		FINISH	Jamy		Sheet No.	2 from 5	

D-SUB / Stamped Pin / Right-Angle
7,2mm US-Norm / Z-Shape / Fixed Hex-
Screw/ Male

Part No.: **T24E4001**

Customer:

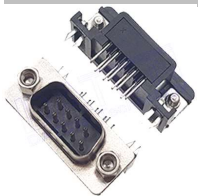

Technical Dimension (mm)

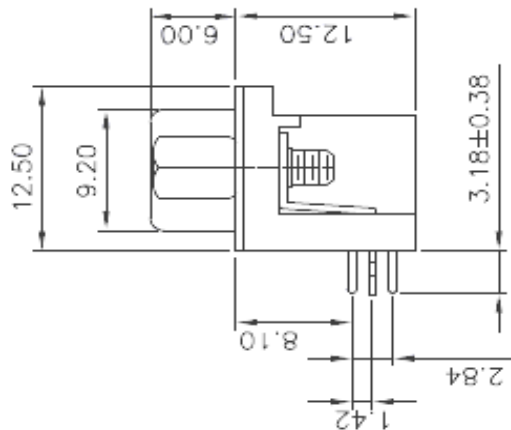

P.C.B. Layout (TOP-VIEW) Tol. 0,10mm

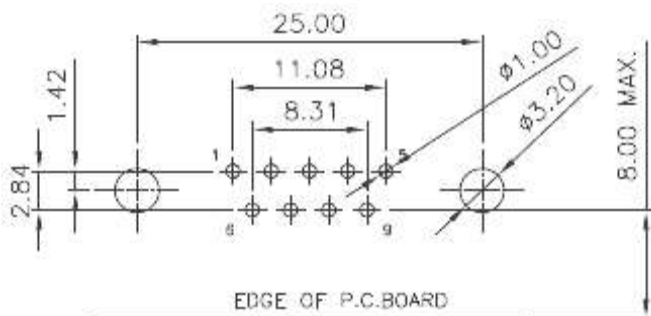

D-SUB / Stamped Pin / Right-Angle
7,2mm US-Norm / Z-Shape / Fixed Hex-
Screw/ Male

Part No.: **T24E4001**

DRW:	Jason	CHKD	Wilson	MATL:	Wilson	TOLERANCE	Mason	DATE	07.02.2023	Customer:
APPD:	Schumi			FINISH	Jamy		Sheet No.	3 from 5		

EDCON-COMPONENTS

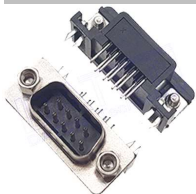

Ordering Informations

Serie	No of Pin	Contact Type	Contact Plating	Shell Plating	Process Option	Parts Option	Parts Option (Screw)	Insulator Colour	ROHS	Packing Code
-------	-----------	--------------	-----------------	---------------	----------------	--------------	----------------------	------------------	------	--------------

T24E4001	09	M	SF	T	A	A	X	BK	R	TY
-----------------	-----------	----------	-----------	----------	----------	----------	----------	-----------	----------	-----------

09= 9Pos.	M= Male	SF= Sel. Gold flash (Standard) S1= 3µ AU S2= 5µ AU S3= 15µ AU S4= 30µ AU	T= Tin + Dimple	A= Boardlock Z-Shape	A= Non Rivet	C= Fixed-Hex-Screw 4,8x11,8mm E= Fixed-Hex-Screw 5,8x12,0mm	BK= Black Colour BL= Blue Colour	R= ROHS Conform N= NON ROHS Conform	TY= Tray Packing BU= Bulk-Ware IV= Individual Package
------------------	----------------	---	------------------------	-----------------------------	---------------------	--	---	--	--

Part-Option Table

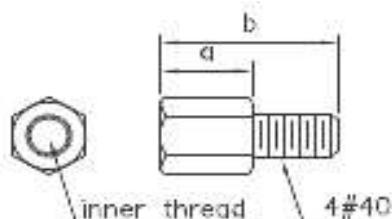

parts no.	DIM. a	DIM. b	inner thread
C	4.8	11.8	4#40
E	5.8	12.0	4#40

**D-SUB / Stamped Pin / Right-Angle
7,2mm US-Norm / Z-Shape / Fixed Hex-Screw/ Male**

Part No.: **T24E4001**

DRW:	Jason	CHKD	Wilson	MATL:	Wilson	TOLERANCE	Mason	DATE	07.02.2023	Customer:
APPD:	Schumi			FINISH	Jamy		Sheet No.	4 from 5		

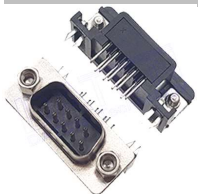

Soldering Profile Curve

Classification Reflow Profile (JEDEC J-STD-020C)



D-SUB / Stamped Pin / Right-Angle
7,2mm US-Norm / Z-Shape / Fixed Hex-
Screw/ Male

Part No.: **T24E4001**

DRW:	Jason	CHKD	Wilson	MATL:	Wilson	TOLERANCE	Mason	DATE	07.02.2023
APPD:	Schumi			FINISH	Jamy		Sheet No.		5 from 5

Customer: