



# DATA SHEET

D-SUB / Machined Pin / PCB-Straight / Front-Hex-Nut / Female

## Serie: T24D9018

D-SUB / Machined Pin / PCB-Straight / Front-Hex-Nut / Female	
Serie No.:	<b>T24D9018</b>
Customer:	

DRW:	Jason	CHKD	Wilson	MATL:	Wilson	TOLERANCE	Mason	DATE	31.01.2023
APPD:	Schumi			FINISH	Jamy		Sheet No.		1 from 15

# EDCON-COMPONENTS



## Technical Informations

<b>Material</b>	
Insulator	PBT +30% GF rated UL-94-V0
Contact:	Brass C3602
Shell:	Steel
Rivet / Boardlock::	Copper Alloy
Contact Plating:	Gold Flash over 40µ Nickel on all area, Contact area see Ordering
<b>Electrical</b>	
Operating Voltage:	250VAC max.
Current Rating:	3,0A max.
Contact Resistance:	15m Ω max.
Insulation Resistance:	3000M Ω min. @ 500VDC
Dielectric withstanding Voltage:	1000VAC 1 Minute
<b>Mechanical:</b>	
Operating Temperature Range:	.-55°C to + 105°C

## Technical Dimensions (mm)

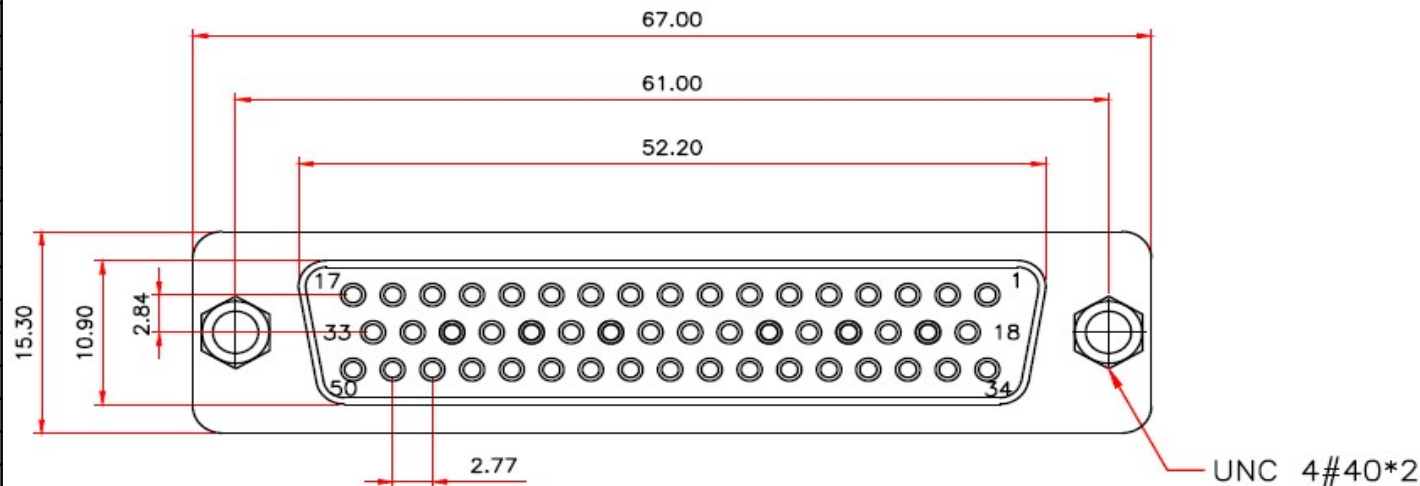

### Tolerances unless otherwise specified (mm)

X	X.X	X.XX	X.XXX	Angle
±0,5	±0,3	±0,2	±	±5°

D-SUB / Machined Pin / PCB-Straight / Front-Hex-Nut / Female

Part No.: **T24D9018**

DRW:	Jason	CHKD	Wilson	MATL:	Wilson	TOLERANCE	Mason	DATE	31.01.2023
APPD:	Schumi	182AE15MGPFEA3		FINISH	Jamy		Sheet No.	2 from 5	

Customer:

[www.edcon-components.com](http://www.edcon-components.com)

email: [info@edcon-components.com](mailto:info@edcon-components.com)

# EDCON-COMPONENTS



## Technical Dimension (mm)

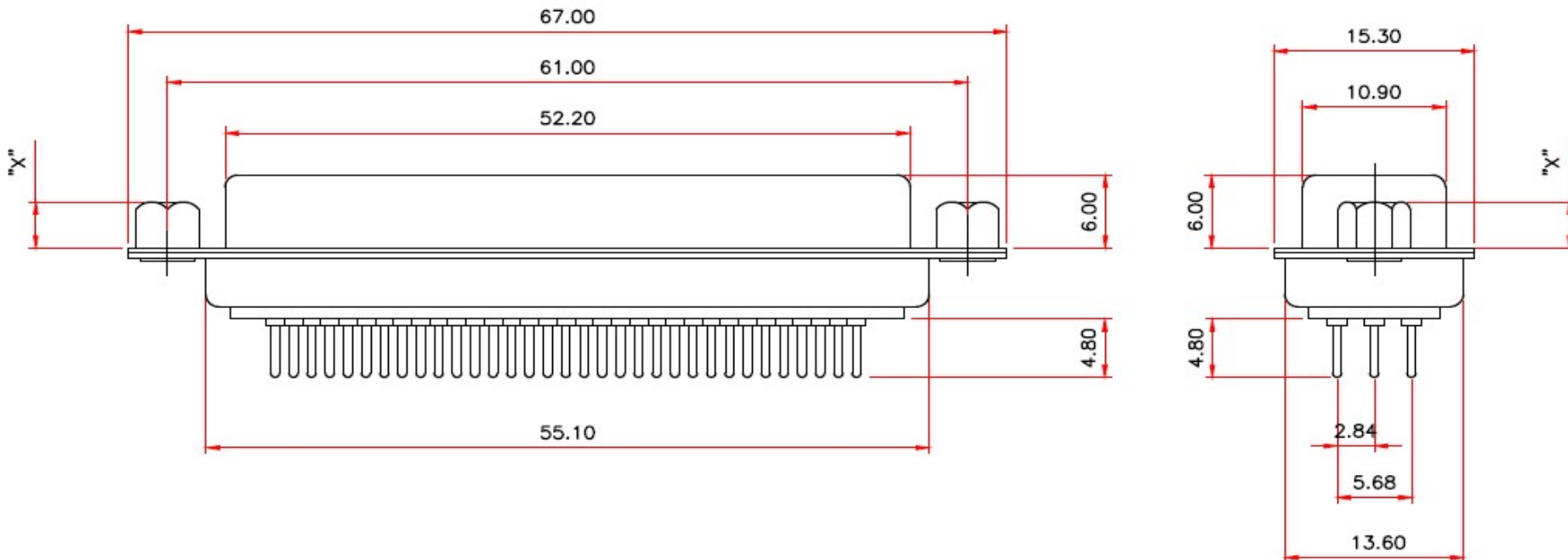

## PCB-Layout (TOP-VIEW) To. +/- 0,10mm

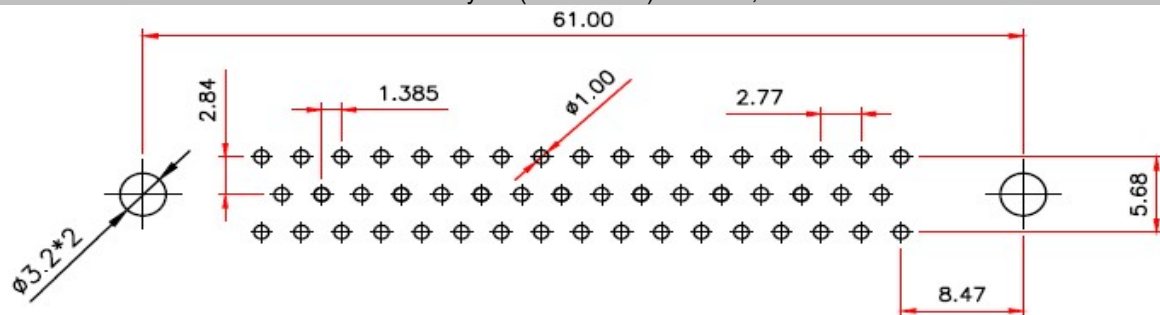

D-SUB / Machined Pin / PCB-Straight /  
Front-Hex-Nut / Female

Part No.: **T24D9018**

DRW:	Jason	CHKD	Wilson	MATL:	Wilson	TOLERANCE	Mason	DATE	31.01.2023
APPD:	Schumi			FINISH	Jamy		Sheet No.		3 from 5

[www.edcon-components.com](http://www.edcon-components.com)

email: [info@edcon-components.com](mailto:info@edcon-components.com)

Copyright by S.Tiede

# EDCON-COMPONENTS



## Ordering Informations

Serie	No of Pin	Contact Type	Contact Plating	Shell Plating	Process Option X,Y	Parts Option	Contact Inserting Optio	Insulator Colour	ROHS	Packing Code
-------	-----------	--------------	-----------------	---------------	--------------------	--------------	-------------------------	------------------	------	--------------

<b>T24D9018</b>	<b>50</b>	<b>F</b>	<b>GF</b>	<b>T</b>	<b>X</b>	<b>B</b>	<b>A</b>	<b>WH</b>	<b>R</b>	<b>TY</b>
-----------------	-----------	----------	-----------	----------	----------	----------	----------	-----------	----------	-----------

		<b>GF=</b> Gold flash (Standard)	<b>T=</b> Tin + Dimple			<b>A=</b> Fully loaded contacts	<b>WH=</b> White	<b>R=</b> ROHS Conform	<b>TY=</b> Tray Packing
	<b>F=</b> Female	<b>G1=</b> 3µ AU		<b>C=</b> Open-Hex Rivet 3,8mm	<b>B=</b> Front Rivet		<b>BK=</b> Black	<b>N=</b> NON ROHS Conform	
		<b>G2=</b> 5µ AU		<b>D=</b> Open-Hex Rivet 5,8mm				<b>BL=</b> Blue	<b>BU=</b> Bulk-Ware
		<b>G3=</b> 15µ AU							<b>IV=</b> Individual Package
<b>50=</b> 50Pos.		<b>G4=</b> 30µ AU		<b>K=</b> Open-Hex Rivet 2,5mm					
				<b>F=</b> Closed-Hex Rivet 5,8mm					

**D-SUB / Machined Pin / PCB-Straight / Front-Hex-Nut / Female**

Part No.: **T24D9018**

DRW:	Jason	CHKD	Wilson	MATL:	Wilson	TOLERANCE	Mason	DATE	31.01.2023	Customer:
APPD:	Schumi			FINISH	Jamy		Sheet No.	4 from 5		



Soldering Profile Curve

Classification Reflow Profile (JEDEC J-STD-020C)

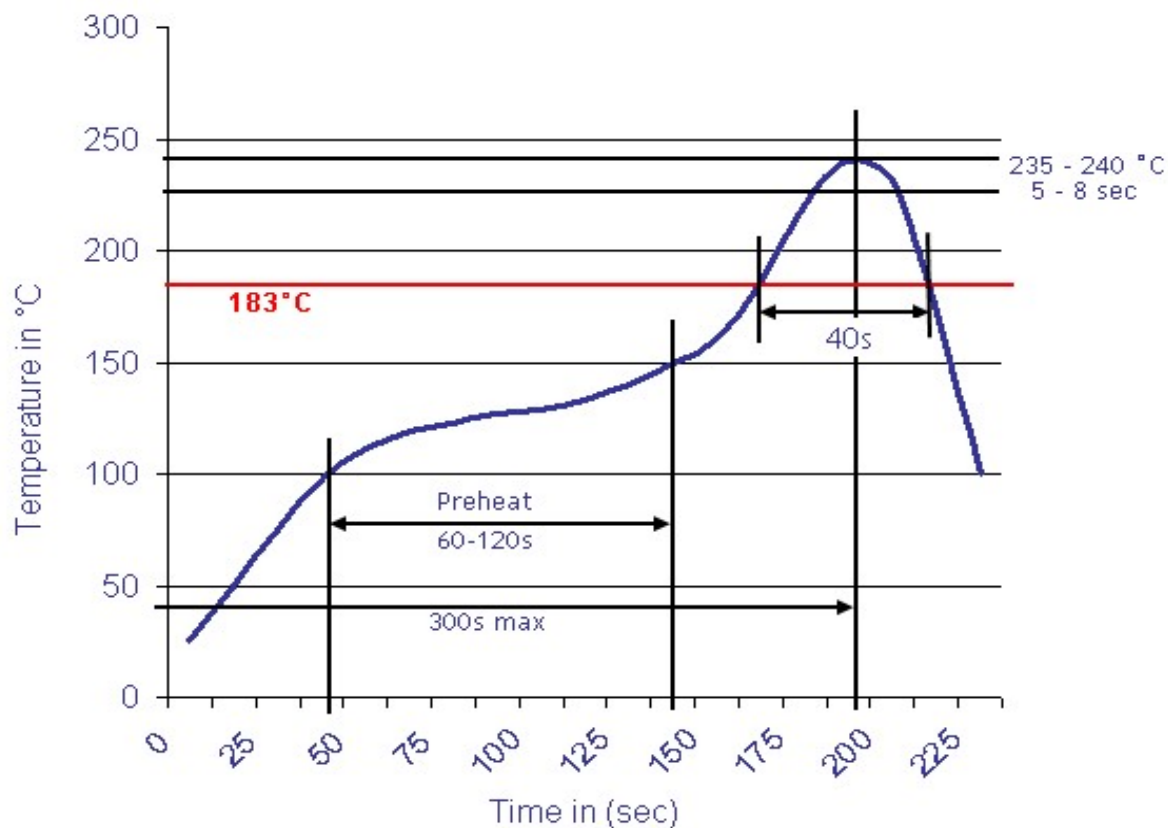

D-SUB / Machined Pin / PCB-Straight / Front-Hex-Nut / Female	
Part No.:	<b>T24D9018</b>
Customer:	

DRW:	Jason	CHKD	Wilson	MATL:	Wilson	TOLERANCE	Mason	DATE	31.01.2023
APPD:	Schumi			FINISH	Jamy		Sheet No.		5 from 5