



DATA SHEET

D-SUB / Machined Pin / Solder-Lug / FRONT-HEX-RIVET / Female

Serie: T24D8023

D-SUB / Machined Pin / Solder-Lug / FRONT-HEX-RIVET / Female	
Serie No.:	T24D8023
Customer:	

DRW:	Jason	CHKD	Wilson	MATL:	Wilson	TOLERANCE	Mason	DATE	29.01.2023
APPD:	Schumi			FINISH	Jamy		Sheet No.		1 from 15

EDCON-COMPONENTS



Technical Informations

Material	
Insulator	PBT +30% GF rated UL-94-V0
Contact:	Brass C3602
Shell:	Steel
Rivet / Boardlock::	Copper Alloy
Contact Plating:	Gold Flash over 40µ Nickel on all area, Contact area see Ordering
Electrical	
Opening Voltage:	250VAC max.
Current Rating:	3,0A max.
Contact Resistance:	15m Ω max.
Insulation Resistance:	3000M Ω min. @ 500VDC
Dielectric withstanding Voltage:	1000VAC 1 Minute
Mechanical:	
Operating Temperature Range:	.-55°C to + 105°C

Technical Dimensions (mm)

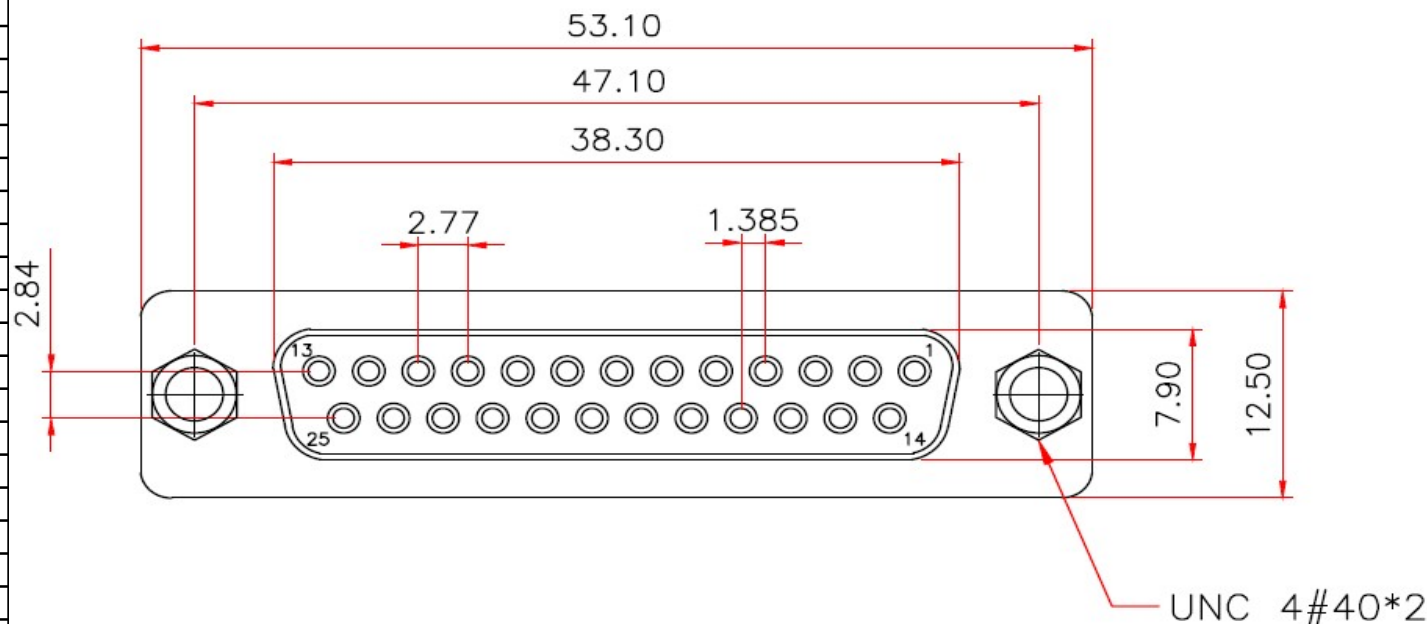

Tolerances unless otherwise specified (mm)				
X	X.X	X.XX	X.XXX	Angle
±0,5	±0,3	±0,2	±	±5°

D-SUB / Machined Pin / Solder-Lug / FRONT-HEX-RIVET / Female	
Part No.:	T24D8023
Customer:	

DRW:	Jason	CHKD	Wilson	MATL:	Wilson
APPD:	Schumi	182AE15MGPF EA3		FINISH	Jamy

Mason	DATE	29.01.2023
Sheet No.		2 from 5

www.edcon-components.com

email: info@edcon-components.com

EDCON-COMPONENTS



Technical Dimension (mm)

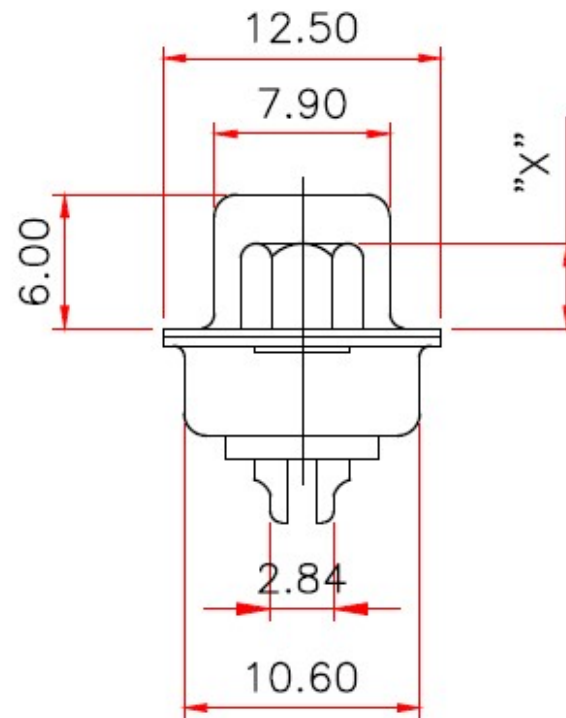
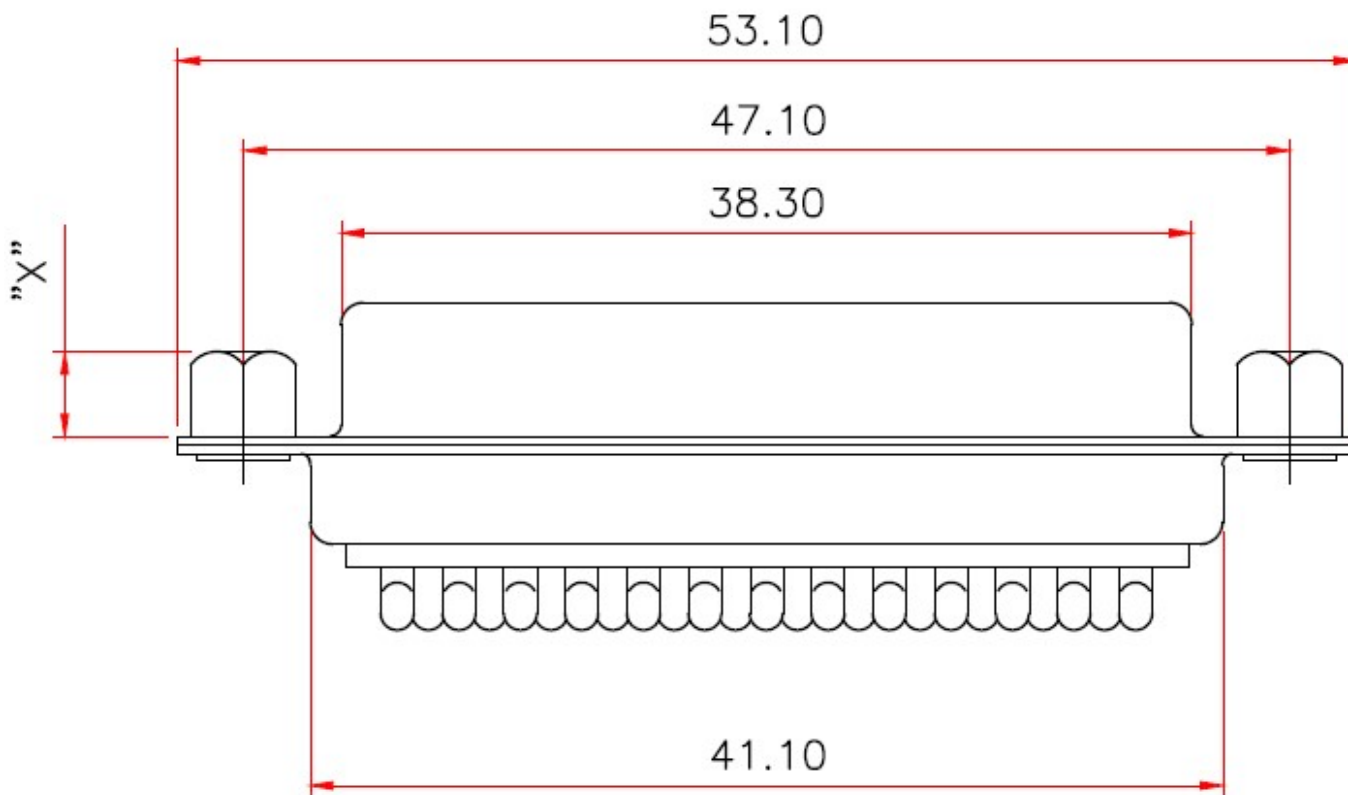

D-SUB / Machined Pin / Solder-Lug /
FRONT-HEX-RIVET / Female

Part No.: **T24D8023**

DRW:	Jason	CHKD	Wilson	MATL:	Wilson	TOLERANCE	Mason	DATE	29.01.2023	Customer:
APPD:	Schumi			FINISH	Jamy		Sheet No.	3 from 5		

www.edcon-components.com

email: info@edcon-components.com

EDCON-COMPONENTS



Ordering Informations

Serie	No of Pin	Contact Type	Contact Plating	Shell Plating	Process Option	Parts Option	Contact Inserting Optio	Insulator Colour	ROHS	Packing Code
-------	-----------	--------------	-----------------	---------------	----------------	--------------	-------------------------	------------------	------	--------------

T24D8023	25	F	GF	T	X	B	A	WH	R	TY
-----------------	-----------	----------	-----------	----------	----------	----------	----------	-----------	----------	-----------

25= 25Pos.	F= Female	GF= Gold flash (Standard) G1= 3µ AU G2= 5µ AU G3= 15µ AU G4= 30µ AU	T= Tin + Dimple	C= Open-Hex-Rivet 3,8mm D= Open-Hex-Rivet 5,8mm K= Open-Hex-Rivet 2,5mm F= Close-Hex-Rivet 5,8mm	B= Front-Rivet	A= Fully loaded contact	WH= White Colour BK= Black Colour BL= Blue Colour	R= ROHS Conform N= NON ROHS Conform	TY= Tray Packing BU= Bulk-Ware IV= Individual Package
-------------------	------------------	--	------------------------	---	-----------------------	--------------------------------	--	--	--

D-SUB / Machined Pin / Solder-Lug / FRONT-HEX-RIVET / Female

Part No.: **T24D8023**

DRW:	Jason	CHKD	Wilson	MATL:	Wilson	TOLERANCE	Mason	DATE	29.01.2023
APPD:	Schumi			FINISH	Jamy		Sheet No.		4 from 5

Customer:



Soldering Profile Curve

Classification Reflow Profile (JEDEC J-STD-020C)



D-SUB / Machined Pin / Solder-Lug / FRONT-HEX-RIVET / Female	
Part No.:	T24D8023
Customer:	

DRW:	Jason	CHKD:	Wilson	MATL:	Wilson	TOLERANCE:	Mason	DATE:	29.01.2023
APPD:	Schumi			FINISH:	Jamy		Sheet No.		5 from 5