

EDCON-COMPONENTS

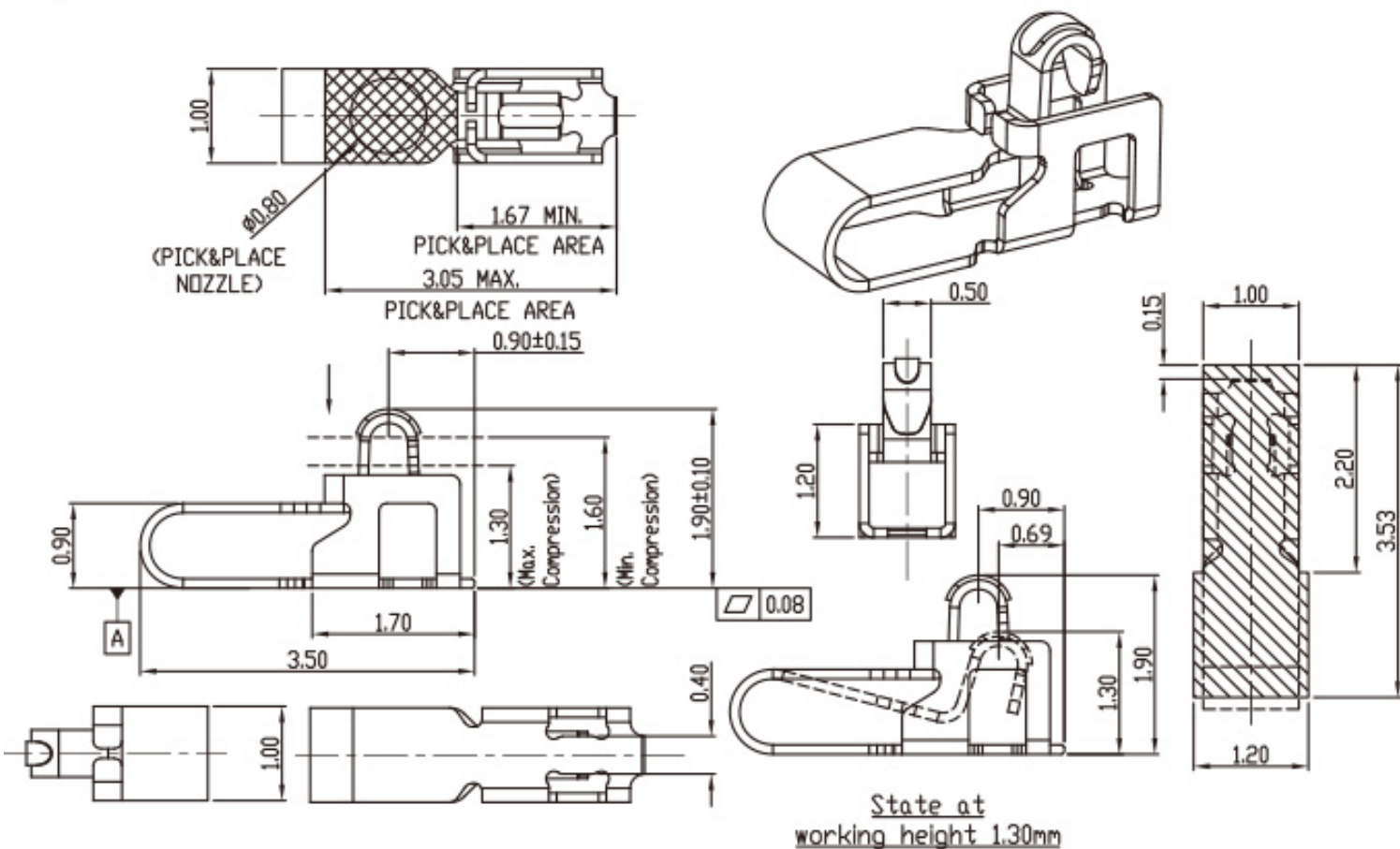

Technical Drawing

Technical Specification



Frequency Range:	DC-3GHz
Impedance:	50Ω
Pre-load Force:	0,3N. Min
Solder Ability:	sold coverage 95%
Center Contact Resistance:	50mΩ Max.
Voltage Standing wave Ratio:	1.5 Max (DC-3GHz)
Insertion Loss	-.0,6dB Max.(DC-3GHz)
Mechanical Durability:	100Cycles
Operating Temperature:	-40°C to +65°C

SPRING RF CONNECTOR CONTACT

Part No.: **TA25003**

Customer:

DRW:	Jason	CHKD	Wilson	MATL:	Wilson	TOLERANCE	Mason	DATE	29.10.2017
APPD:	Schumi			FINISH	Jamy		Sheet No.		1 from 3

EDCON-COMPONENTS



Ordering Informations

Serie	Contact Plating	Spezial Function	Spezial Function	Spezial Function	ROHS	Packing				
-------	-----------------	------------------	------------------	------------------	------	---------	--	--	--	--

TA25003	S0	0	0	0	R	TR				
----------------	-----------	----------	----------	----------	----------	-----------	--	--	--	--

G0 = Gold Flash	0 = No function	0 = No function	0 = No function	R = ROHS Conform	B101 = Bulk-Ware 100PCS TR = Tape Reel
S0 = Selectiv Gold Flash					
T0 = Tinned					

SPRING RF CONNECTOR CONTACT	
Part No.:	TA25003
Customer:	

DRW:	Jason	CHKD	Wilson	MATL:	Wilson	TOLERANCE	Mason	DATE	29.10.2017
APPD:	Schumi			FINISH	Jamy		Sheet No.		2 from 3



Soldering Profile Curve

Classification Reflow Profile (JEDEC J-STD-020C)

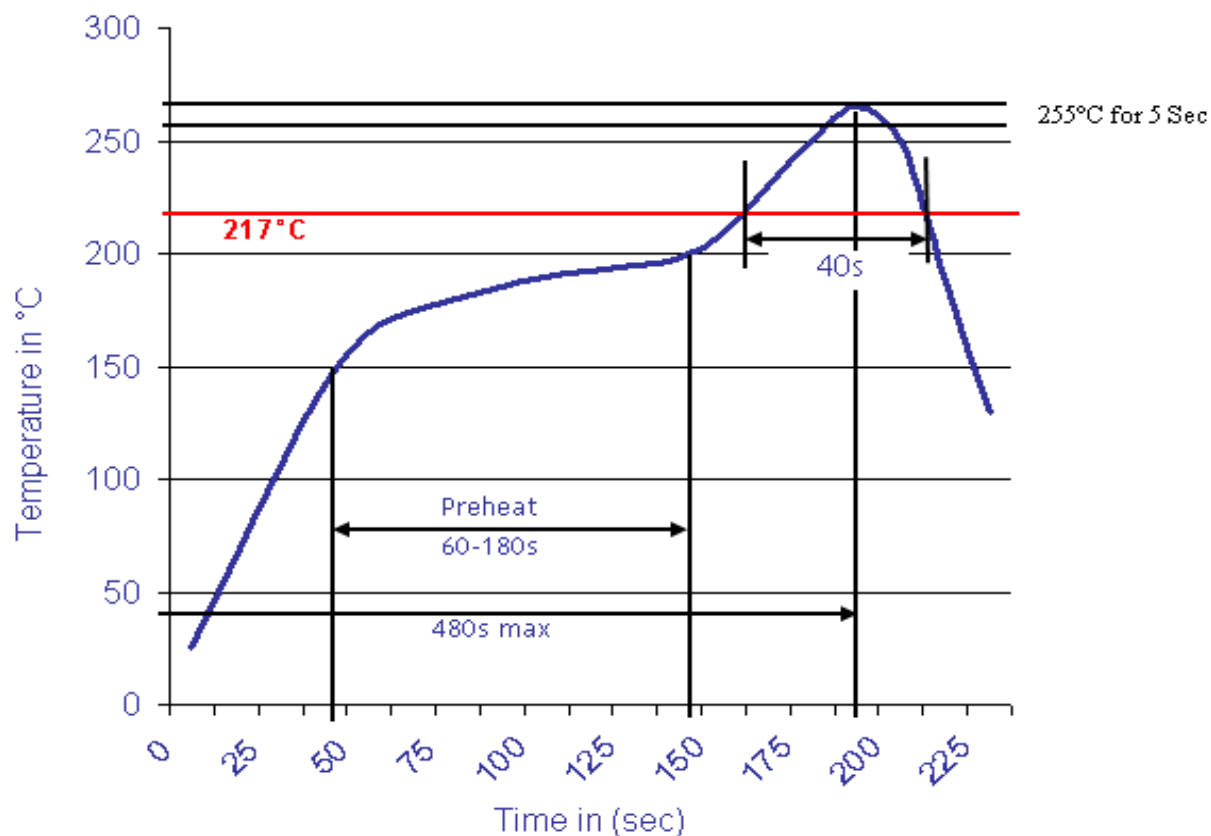

SPRING RF CONNECTOR CONTACT

Part No.: **TA25003**

DRW:	Jason	CHKD	Wilson	MATL:	Wilson	TOLERANCE	Mason	DATE	29.10.2017
APPD:	Schumi			FINISH	Jamy		Sheet No.	3 from 3	Customer: