

EDCON-COMPONENTS



Technical Discription

Drawing

Rated Current: 50mA ~ 6,3A
 Rated Voltage: 250VAC
 Fuse Type/Size: TR2
 Material: PA66/H62
 Soldering Temperature: 240°C
 Approval:

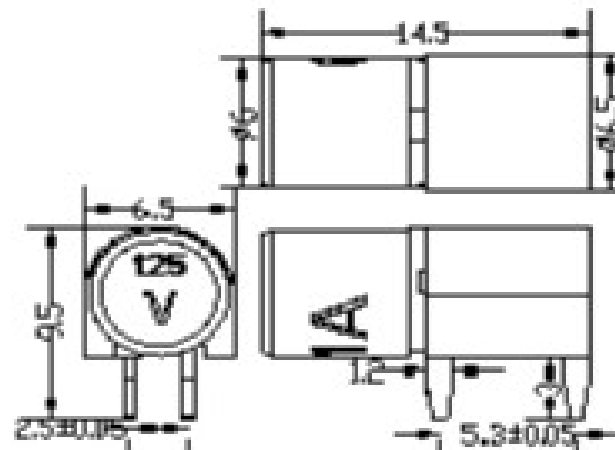

THT TR2 PCB Fuse Holder	
Part No.:	R53075
Customer:	

DRW:	Jason	CHKD:	Wilson	MATL:	Wilson	TOLERANCE:	Mason	DATE:	10.03.2026
APPD:	Schumi	FINISH:	Jamy				Sheet No.		1 from 3

EDCON-COMPONENTS



Ordering Informations

Serie	Spezial Function	Spezial Function	ROHS	Packing						
R53075	0	0	R	BU						

0 = No function	0 = No function	R = ROHS Conform	BU = Bulk-Ware

THT TR2 PCB Fuse Holder
Part No.: R53075
Customer:

DRW:	Jason	CHKD	Wilson	MATL:	Wilson	TOLERANCE	Mason	DATE	10.03.2026
APPD:	Schumi			FINISH	Jamy		Sheet No.	2 from 3	



Soldering Profile Curve

Classification Reflow Profile (JEDEC J-STD-020C)

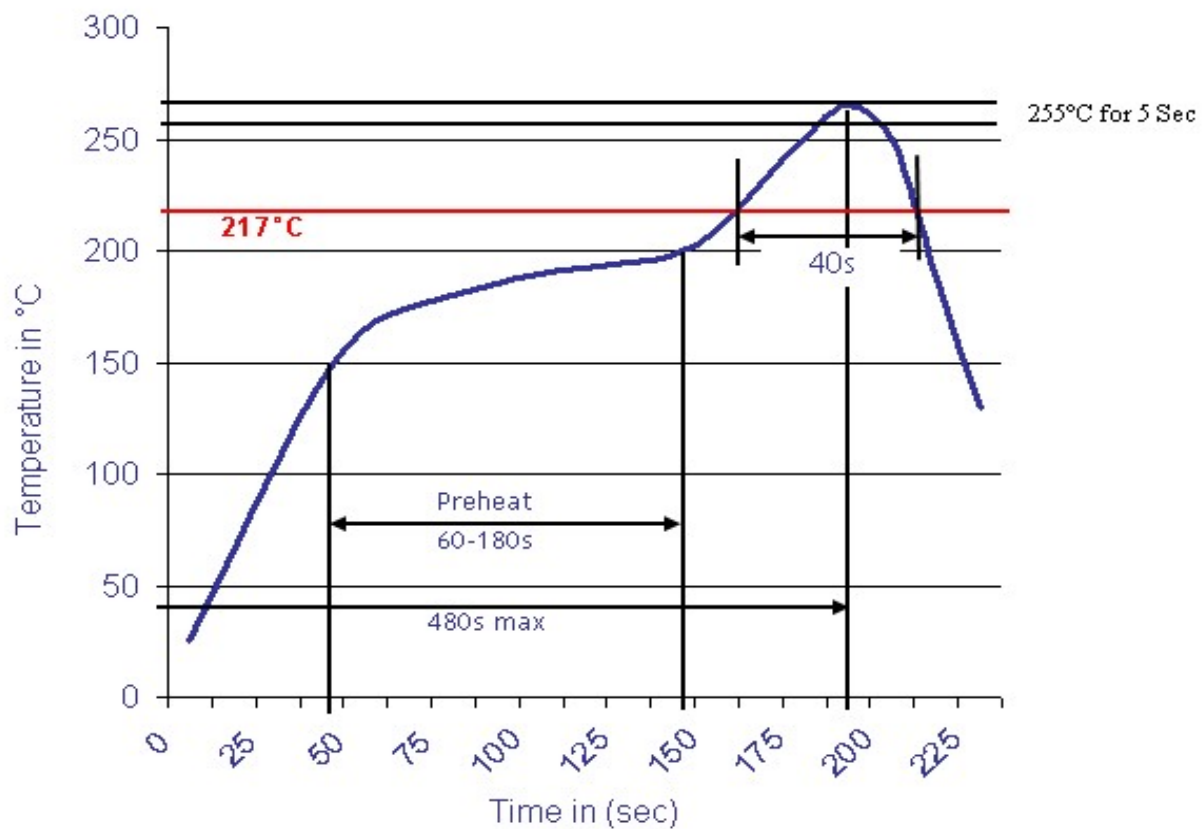

THT TR2 PCB Fuse Holder	
Part No.:	R53075
Customer:	

DRW:	Jason	CHKD:	Wilson	MATL:	Wilson	TOLERANCE:	Mason	DATE:	10.03.2026
APPD:	Schumi	FINISH:	Jamy			Sheet No.:			3 from 3