

EDCON-COMPONENTS



Technical Discription

1 Material:

| | |
|------------------|----------|
| Material Body: | C2700 |
| Gold Plated: | 16-20µm |
| Nickel: | 60-120µm |
| Material Needle: | C3604 |
| Gold Plated: | 4-8µm |
| Nickel: | 60-120µm |
| Spring: | SUS304 |
| Body: | PA46 |

2 Mechanical Properties

| | |
|-----------------|-----------|
| Pitch: | 3,00mm |
| Working height: | 7,8~8,1mm |
| Elastic: | 100 ±20gr |

Lifetime: more than 10000 times

3 Electrical Performance:

| | |
|-------------------------|--|
| 4 Isolation Resistance: | 500M Ohm min. |
| Withstanding Voltage: | 500VAC/DC |
| Max. Rated Voltage: | 36VDC dynamic range of work with impedance less than |

Contact Resistance: <30m Ohm

Rated current: 2,5A

5 Packing Specification:

| | |
|-------------------------------|-----------------|
| 6 Max. Soldering Temperature: | 260°C |
| Operating Temperature: | -.40°C to +85°C |

Drawing

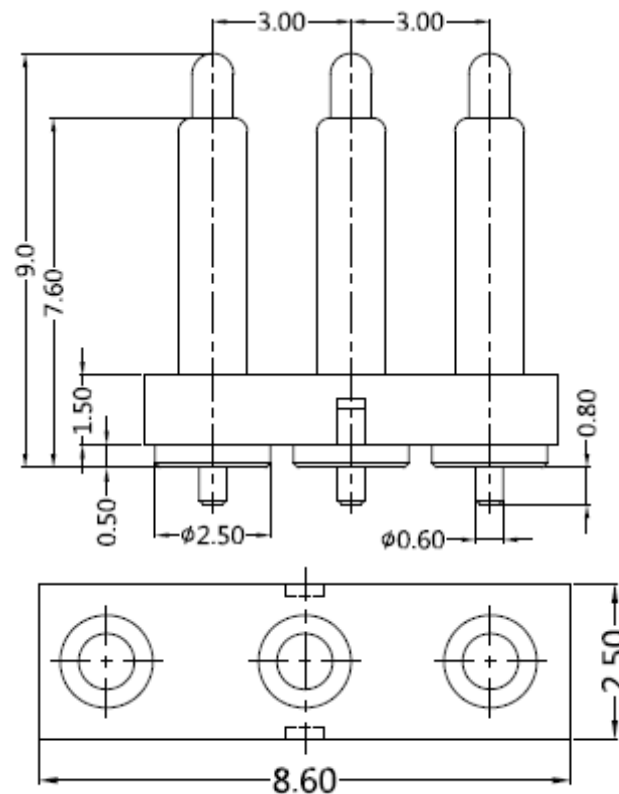
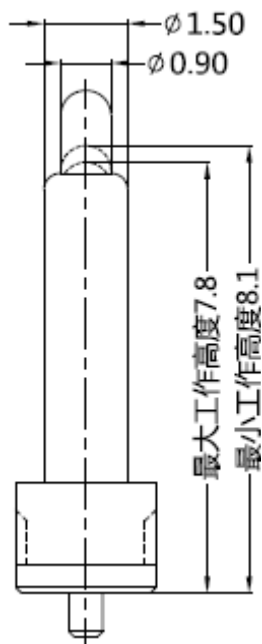

| Tolerance | | | |
|-----------|-----------|----------|------------|
| 0. | 0.0 | 0.00 | 0.000 |
| ± - | ± 0,30 | ± 0,15 | ± - |
| TOLERANCE | Mason | DATE | 08.12.2017 |
| APPD: | Sheet No. | 1 from 3 | |

| | |
|------------------------------------|------------------|
| THT 3 POGO PIN with Plastic | |
| Part No.: | TA23C3098 |
| Customer: | |

| | | | | | |
|-------|--------|------|--------|--------|--------|
| DRW: | Jason | CHKD | Wilson | MATL: | Wilson |
| APPD: | Schumi | | | FINISH | Jamy |

EDCON-COMPONENTS



PCB Layout (mm)

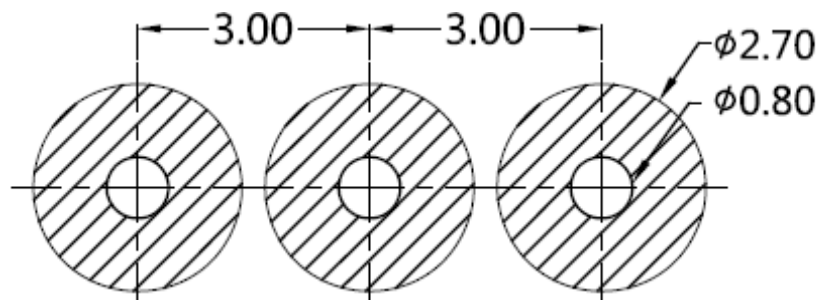

Ordering Informations

| Serie | Number of Position | Material Body | Material Needle | Contact Plat. Body | Contact Plat. Needle | Spezial Function | ROHS | Packing | | |
|-----------|--------------------|---------------|-----------------|--------------------|----------------------|------------------|------|---------|--|--|
| TA23C3098 | 03 | A | A | G0 | G0 | N | R | BU | | |

| | | | | | | | |
|--------------|-------------------|-------------------|----------------------------|-------------------------|----------------|-----------------|------------------------|
| 03= Position | A= Material C3604 | A= Material C3604 | G0= Gold Flash <16-20µinch | G0= Gold Flash 4-8µinch | N= No function | R= ROHS Conform | BU= Bulk-Ware Standard |
| | B= Material C2700 | B= Material C2700 | | | | | |
| | | | NO= Nickel 60-120µinch | NO= Nickel 60-120µinch | | | TU= Tube Packing |

**THT 3 POGO PIN
with Plastic**

Part No.: TA23C3098

| | | | | | | | | | | |
|-------|--------|------|--------|--------|--------|-----------|-----------|----------|------------|-----------|
| DRW: | Jason | CHKD | Wilson | MATL: | Wilson | TOLERANCE | Mason | DATE | 08.12.2017 | Customer: |
| APPD: | Schumi | | | FINISH | Jamy | | Sheet No. | 2 from 3 | | |



Soldering Profile Curve

Classification Reflow Profile (JEDEC J-STD-020C)



| | |
|--|------------------|
| THT 3 POGO PIN with Plastic | |
| Part No.: | TA23C3098 |
| Customer: | |

| | | | | | | | | | |
|-------|--------|------|--------|--------|--------|-----------|-----------|----------|------------|
| DRW: | Jason | CHKD | Wilson | MATL: | Wilson | TOLERANCE | Mason | DATE | 08.12.2017 |
| APPD: | Schumi | | | FINISH | Jamy | | Sheet No. | 3 from 3 | |