

# EDCON-COMPONENTS



## Technical Discription

## Drawing

### 1 Material:

Material Body: C2700  
 Gold Plated: 16-20µm  
 Nickel: 60-120µm  
 Material Needle: C3604  
 Gold Plated: 4-8µm  
 Nickel: 60-120µm  
 Spring: SUS304  
 Body: PA46

### 2 Mechanical Properties

Pitch: 4,00mm  
 Working height: 2,6~2,9mm  
 Elastic: 85 ±15gr

Lifetime:more than 10000 times

### 3 Electrical Performance:

4 **Isolation Resistance:** 500M Ohm min.  
 Withstanding Voltage: 500VAC/DC  
 Max.Rated Voltage: 36VDC dynamic range of work with impedance less than

Contact Resistance: <30m Ohm

Rated current: 2,5A

### 5 Packing Specification:

6 Max.Soldering Temperature: 260°C  
 Operating Temperature: -40°C to +85°C

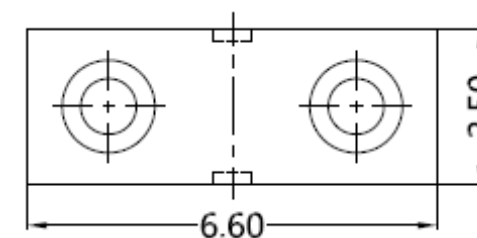
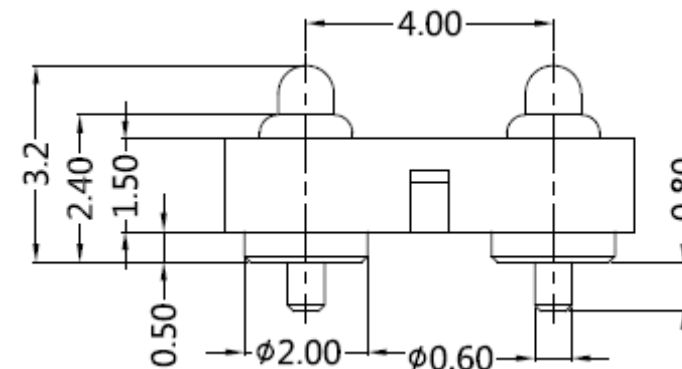
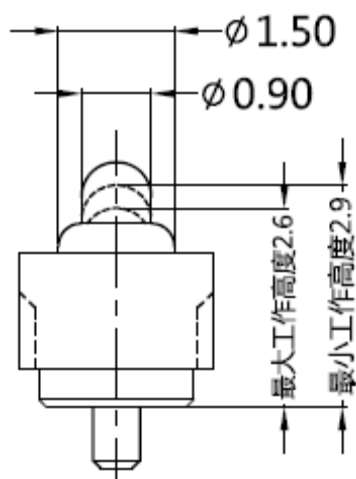

Tolerance			
0.	0.0	0.00	0.000
± -	± 0,30	± 0,15	± -
TOLERANCE	Mason	DATE	07.12.2017
	Sheet No.		1 from 3

## THT 2 POGO PIN with Plastic

Part No.: TA23C2116

Customer:

DRW:	Jason	CHKD	Wilson	MATL:	Wilson
APPD:	Schumi			FINISH	Jamy

# EDCON-COMPONENTS



## PCB Layout ( mm)

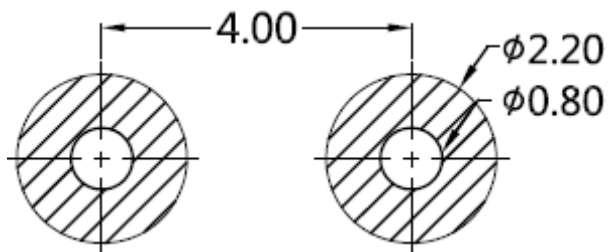

## Ordering Informations

Serie	Number of Position	Material Body	Material Needle	Contact Plat. Body	Contact Plat. Needle	Spezial Function	ROHS	Packing		
TA23C2116	02	A	A	G0	G0	N	R	BU		

02= Position	A= Material C3604	A= Material C3604	G0= Gold Flash <16-20µinch	G0= Gold Flash 4-8µinch	N= No function	R= ROHS Conform	BU= Bulk-Ware Standard
	B= Material C2700	B= Material C2700					
			NO= Nickel 60-120µinch	NO= Nickel 60-120µinch			TU= Tube Packing

**THT 2 POGO PIN with Plastic**  
Part No.: TA23C2116

DRW:	Jason	CHKD	Wilson	MATL:	Wilson	TOLERANCE	Mason	DATE	07.12.2017	Customer:
APPD:	Schumi			FINISH	Jamy		Sheet No.	2 from 3		



Soldering Profile Curve

Classification Reflow Profile (JEDEC J-STD-020C)



<b>THT 2 POGO PIN with Plastic</b>	
Part No.:	<b>TA23C2116</b>
Customer:	

DRW:	Jason	CHKD	Wilson	MATL:	Wilson	TOLERANCE	Mason	DATE	07.12.2017
APPD:	Schumi			FINISH	Jamy		Sheet No.	3 from 3	