

# EDCON-COMPONENTS



## Technical Discription

## Drawing

### 1 Material:

Material Body:	C2700
Gold Plated	16-20µm
Nickel	60-120µm
Material Needle	C3604
Gold Plated	4-8µm
Nickel	60-120µm
Spring:	SUS304

### 2 Mechanical Properties

Working height:	7,4-7,7mm
Elastic	100 ± 20gr
Max. Compression stroke	1,3 mm
Lifetime:more than	10000 times

### 3 Electrical Performance:

Max.Rated Voltage:	36VDC dynamic range of work with impedance less than
Contact Resistance:	<30m Ohm
Rated current:	2,5A
4 Max.Soldering Temperature:	260°C
Operating Temperature:	.-40°C to +85°C

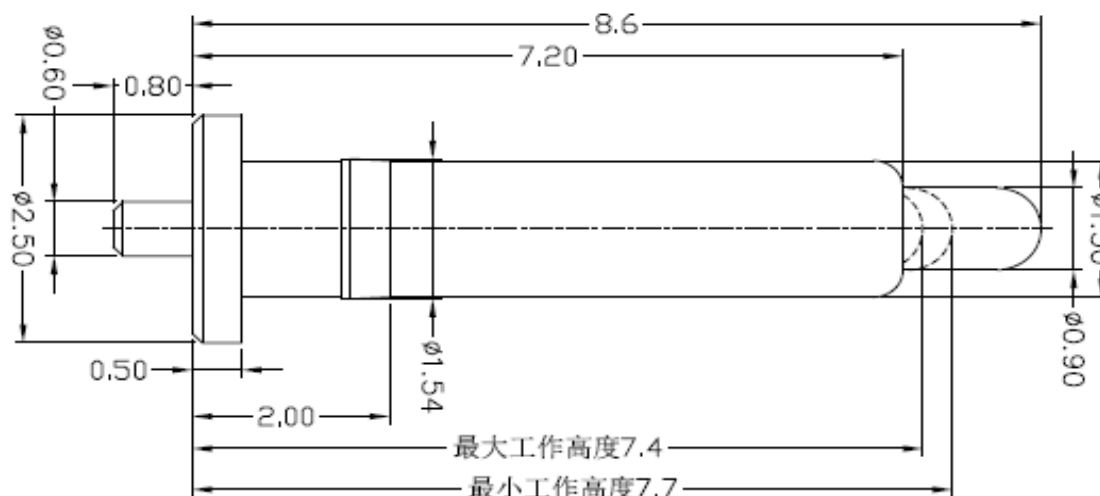

## THT Single POGO PIN

Part No.: **TA23C1028**

Customer:

DRW:	Jason	CHKD	Wilson	MATL:	Wilson	TOLERANCE	Mason	DATE	06.12.2017
APPD:	Schumi			FINISH	Jamy		Sheet No.		1 from 3

# EDCON-COMPONENTS



## Ordering Informations

Serie	Number of Position	Material Body	Material Needle	Contact Plat. Body	Contact Plat. Needle	Spezial Function	ROHS	Packing		
-------	--------------------	---------------	-----------------	--------------------	----------------------	------------------	------	---------	--	--

<b>TA23C1028</b>	<b>01</b>	<b>A</b>	<b>A</b>	<b>G0</b>	<b>G0</b>	<b>N</b>	<b>R</b>	<b>BU</b>		
------------------	-----------	----------	----------	-----------	-----------	----------	----------	-----------	--	--

<b>01</b> = Single Pole	<b>A</b> = Material C3604	<b>A</b> = Material C3604	<b>G0</b> = Gold Flash <16-20µinch	<b>G0</b> = Gold Flash 4-8µinch	<b>N</b> = No function	<b>R</b> = ROHS Conform	<b>BU</b> = Bulk-Ware Standard
	<b>B</b> = Material C2700	<b>B</b> = Material C2700					
			<b>NO</b> = Nickel 60-120µinch	<b>NO</b> = Nickel 60-120µinch			

**THT Single POGO PIN**

Part No.: **TA23C1028**

DRW:	Jason	CHKD	Wilson	MATL:	Wilson	TOLERANCE	Mason	DATE	06.12.2017
APPD:	Schumi			FINISH	Jamy		Sheet No.		2 from 3

Customer:

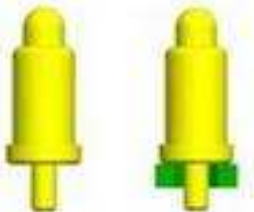

Soldering Profile Curve

Classification Reflow Profile (JEDEC J-STD-020C)



<b>THT Single POGO PIN</b>
Part No.: <b>TA23C1028</b>
Customer:

DRW:	Jason	CHKD	Wilson	MATL:	Wilson	TOLERANCE	Mason	DATE	06.12.2017
APPD:	Schumi			FINISH	Jamy		Sheet No.	3 from 3	