

# EDCON-COMPONENTS



## Technical Discription

### 1 Material:

Material Body: C2700  
 Gold Plated: 16-20µm  
 Nickel: 60-120µm  
 Material Needle: C3604  
 Gold Plated: 4-8µm  
 Nickel: 60-120µm  
 Spring: SUS304  
 Body: PA46

### 2 Mechanical Properties

Pitch: 3,5mm  
 Working height: 2,0~2,3mm  
 Elastic: 65 ± 15g

Lifetime: more than 10000 times

### 3 Electrical Performance:

4 Isolation Resistance: 500M Ohm min.  
 Withstanding Voltage: 500VAC/DC  
 Max. Rated Voltage: 36VDC dynamic range of work with impedance less than

Contact Resistance: <30m Ohm

Rated current: 2,5A

5 Packing Specification: EIA 481

6 Max. Soldering Temperature: 260°C

Operating Temperature: -40°C to +85°C

## Drawing

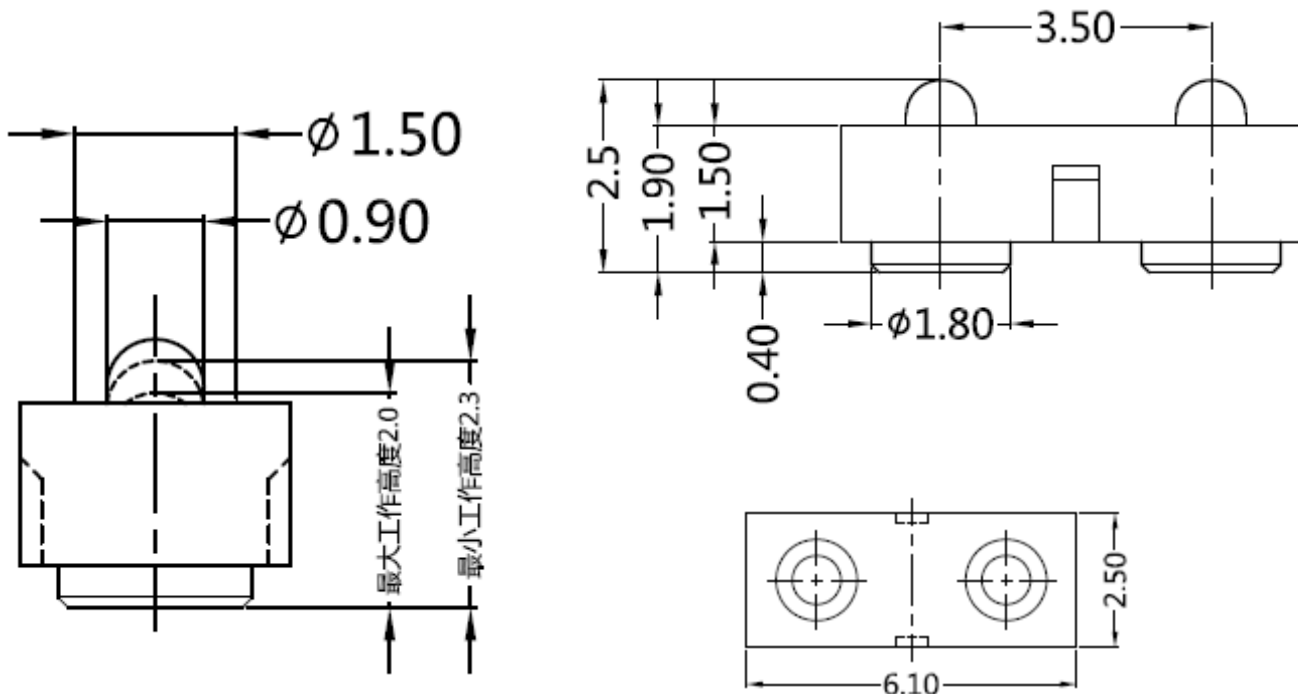

							Tolerance				<b>2 POGO PIN with Plastic</b>
							0.	0.0	0.00	0.000	
							± -	± 0,30	± 0,15	± -	Part No.: <b>TA23B3072</b>
DRW:	Jason	CHKD	Wilson	MATL:	Wilson	TOLERANCE	Mason	DATE	22.11.2017	Customer:	
APPD:	Schumi			FINISH	Jamy		Sheet No.	1 from 3			

# EDCON-COMPONENTS



## PCB Layout ( mm)

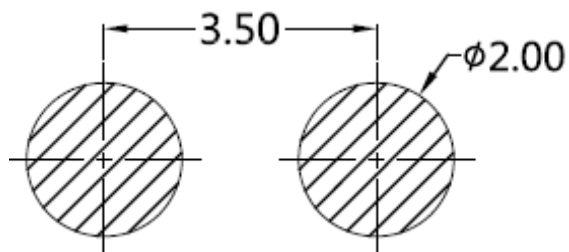

## Ordering Informations

Serie	Number of Position	Material Body	Material Needle	Contact Plat. Body	Contact Plat. Needle	Spezial Function	ROHS	Packing		
TA23B3072	02	A	A	G0	G0	N	R	BU		

02= Single Pole	A= Material C3604	A= Material C3604	G0= Gold Flash <16-20µinch	G0= Gold Flash 4-8µinch	N= No function	R= ROHS Conform	BU= Bulk-Ware Standard
	B= Material C2700	B= Material C2700					
			NO= Nickel 60-120µinch	NO= Nickel 60-120µinch			TR= Tape Reel

**2 POGO PIN with Plastic**  
Part No.: TA23B3072

DRW:	Jason	CHKD	Wilson	MATL:	Wilson	TOLERANCE	Mason	DATE	22.11.2017	Customer:
APPD:	Schumi			FINISH	Jamy		Sheet No.	2 from 3		



Soldering Profile Curve

Classification Reflow Profile (JEDEC J-STD-020C)



<b>2 POGO PIN with Plastic</b>	
Part No.:	<b>TA23B3072</b>
Customer:	

DRW:	Jason	CHKD	Wilson	MATL:	Wilson	TOLERANCE	Mason	DATE	22.11.2017
APPD:	Schumi			FINISH	Jamy		Sheet No.	3 from 3	