



Technical Discription

1 Material:

Material Body:	C2700
Gold Plated	16-20µm
Nickel	60-120µm
Material Needle	C3604
Gold Plated	4-8µm
Nickel	60-120µm
Spring:	SUS304

2 Mechanical Properties

Working height:	5,6~5,9mm
Elastic	100 ± 20g
Max. Compression stroke	1,2mm
Lifetime:more than	10000 times

3 Electrical Performance:

Max.Rated Voltage: 36VDC dynamic range of work with impedance less than

Contact Resistance: <30m Ohm

Rated current: 2,5A

4 Max.Soldering Temperature: 260°C

Operating Temperature: -40°C to +85°C

Drawing

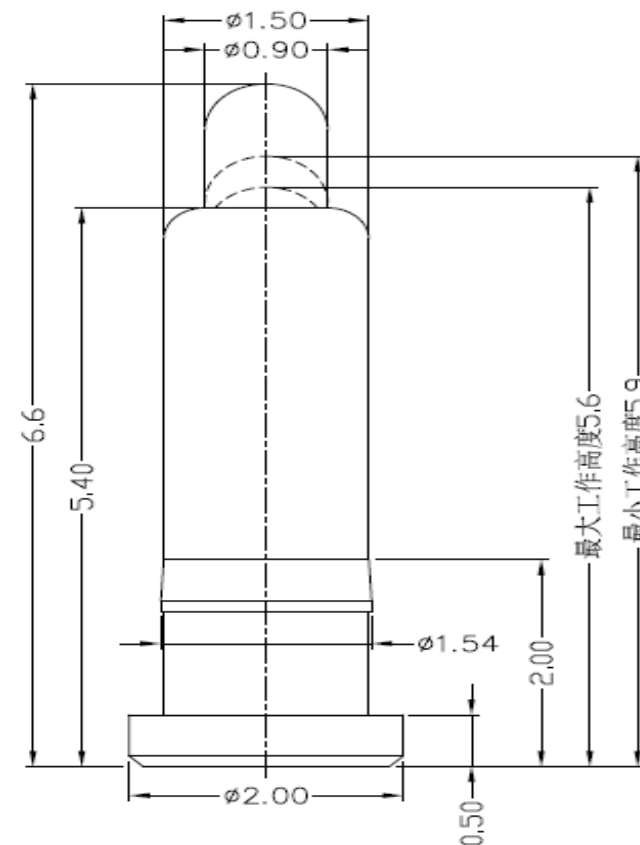

SMD Single POGO PIN

Part No.: **TA23A819**

Customer:

DRW:	Jason	CHKD	Wilson	MATL:	Wilson	TOLERANCE	Mason	DATE	21.11.2017
APPD:	Schumi			FINISH	Jamy		Sheet No.		1 from 3

EDCON-COMPONENTS



Ordering Informations

Serie	Number of Position	Material Body	Material Needle	Contact Plat. Body	Contact Plat. Needle	Spezial Function	ROHS	Packing		
-------	--------------------	---------------	-----------------	--------------------	----------------------	------------------	------	---------	--	--

TA23A819	01	A	A	G0	G0	N	R	BU		
-----------------	-----------	----------	----------	-----------	-----------	----------	----------	-----------	--	--

01 = Single Pole	A = Material C3604	A = Material C3604	G0 = Gold Flash <16-20µinch	G0 = Gold Flash 4-8µinch	N = No function	R = ROHS Conform	BU = Bulk-Ware Standard
	B = Material C2700	B = Material C2700					
			NO = Nickel 60-120µinch	NO = Nickel 60-120µinch			TR = Tape Reel

SMD Single POGO PIN

Part No.: **TA23A819**

DRW:	Jason	CHKD	Wilson	MATL:	Wilson	TOLERANCE	Mason	DATE	21.11.2017
APPD:	Schumi			FINISH	Jamy		Sheet No.		2 from 3

Customer:



Soldering Profile Curve

Classification Reflow Profile (JEDEC J-STD-020C)

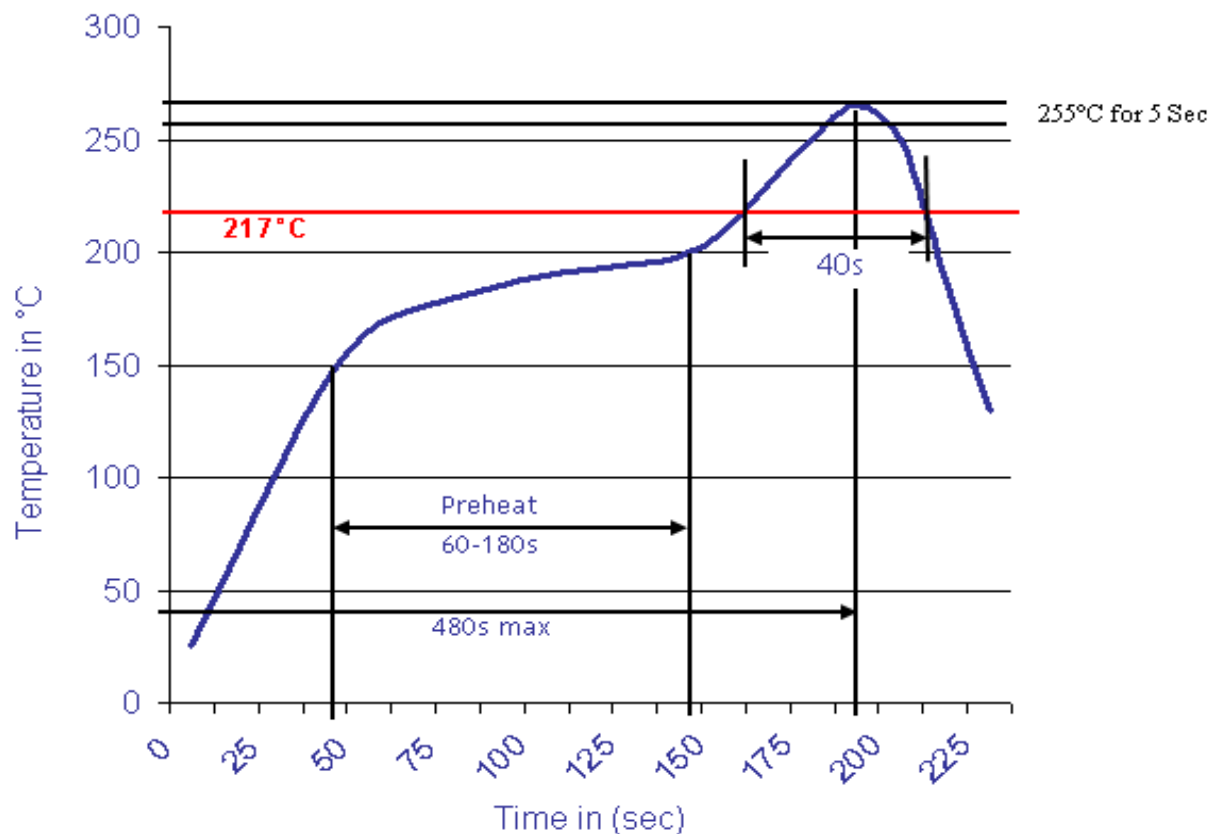

**SMD Single POGO
PIN**

Part No.: **TA23A819**

DRW:	Jason	CHKD	Wilson	MATL:	Wilson	TOLERANCE	Mason	DATE	21.11.2017	Customer:
APPD:	Schumi			FINISH	Jamy		Sheet No.	3 from 3		