

EDCON-COMPONENTS

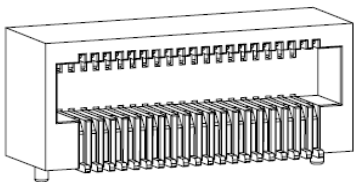

Specifications

Current Rating: 0,3A
 Voltage Rating: 50V AC/DC
 Withstanding Voltage: 500V AC f. 1Minute
 Contact Resistance: 60milli Ohm max.
 Insulation Resistance: 100M Ohm min.
 Operating Temperature: . -25°C ~ to +80°C
 Insulator Material: PA9T, Plastic UL94V-0

Material + Plating

Contact Pin: Brass

Contact Plating: like ordering code

P.C.B Layout

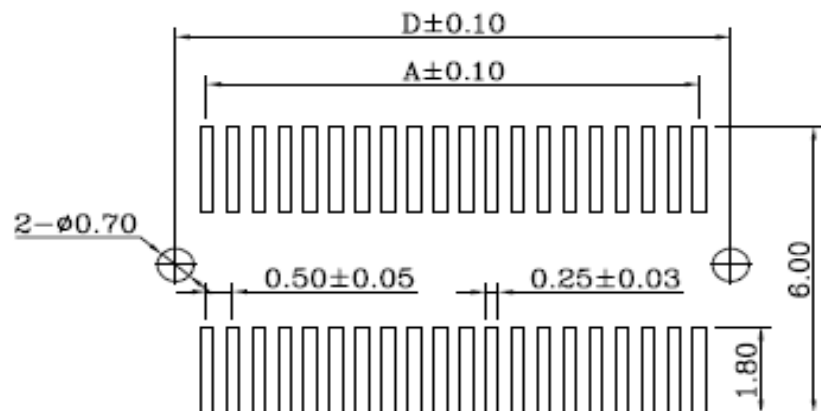

Drawing

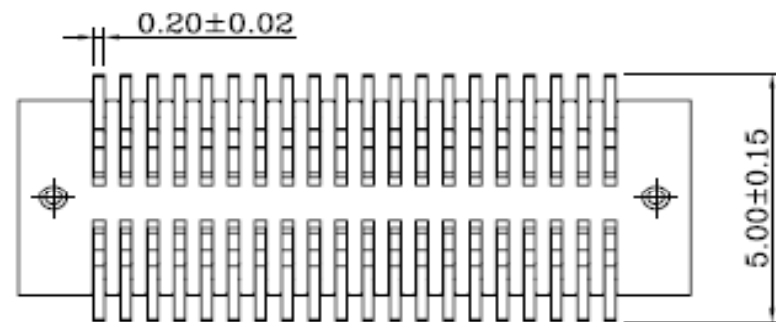
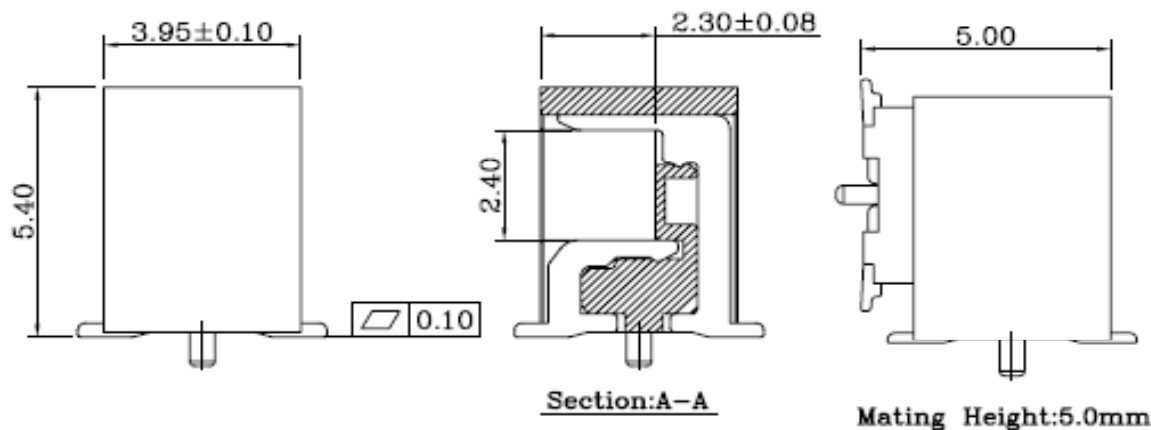

**Board to Board Connector
Pitch 0,50mm**

Part No.: **T15F001**

DRW:	Jason	CHKD	Wilson	MATL:	Wilson	TOLERANCE	Mason	DATE	02.10.2021
APPD:	Schumi			FINISH	Jamy		Sheet No.	1 from 4	Customer:

www.edcon-components.com

email: info@edcon-components.com

EDCON-COMPONENTS

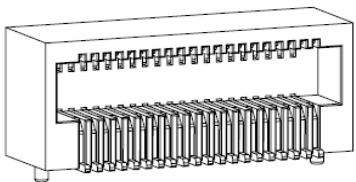

Technical Dimensions

Insulator Height Female				
No Pos.	A	B	C	D
2x5	2,00	5,00	4,03	3,70
2x6	2,50	5,50	4,53	4,20
2x7	3,00	6,00	5,03	4,70
2x8	3,50	6,50	5,53	5,20
2x9	4,00	7,00	6,03	5,70
2x10	4,50	7,50	6,53	6,20
2x11	5,00	8,00	7,03	6,70
2x12	5,50	8,50	7,53	7,20
2x13	6,00	9,00	8,03	7,70
2x14	6,50	9,50	8,53	8,20
2x15	7,00	10,00	9,03	8,70
2x16	7,50	10,50	9,53	9,20
2x17	8,00	11,00	10,03	9,70
2x18	8,50	11,50	10,53	10,20
2x19	9,00	12,00	11,03	10,70
2x20	9,50	12,50	11,53	11,20

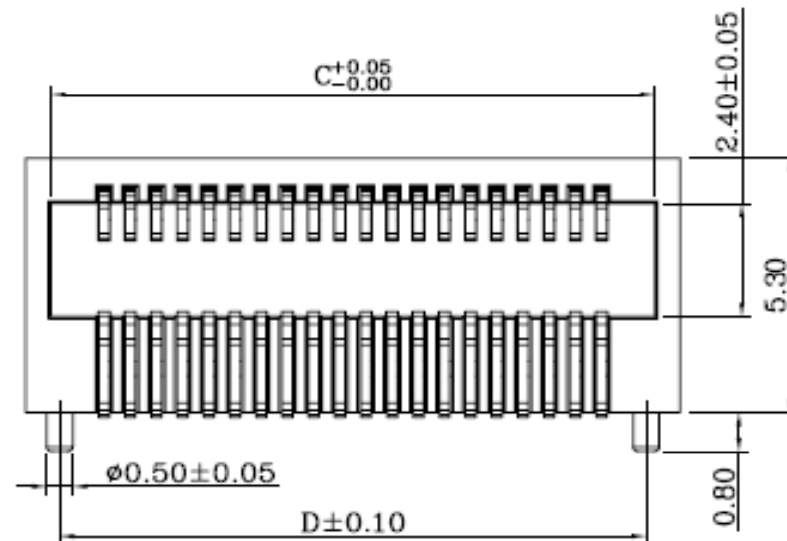
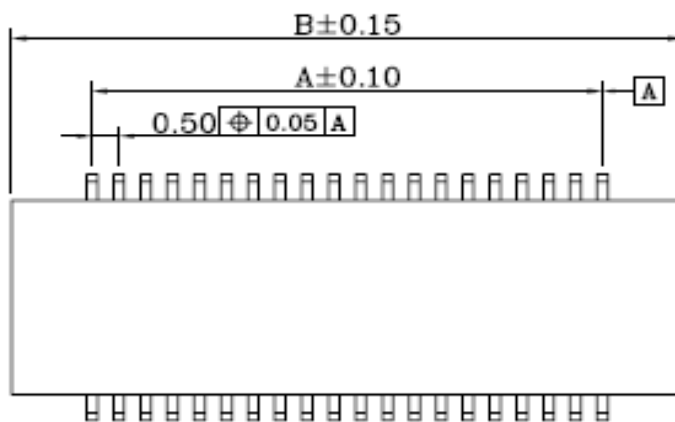

Board to Board Connector	
Pitch 0,50mm	
Part No.:	T15F001
Customer:	

DRW:	Jason	CHKD	Wilson	MATL:	Wilson	TOLERANCE	Mason	DATE	02.10.2021
APPD:	Schumi			FINISH	Jamy		Sheet No.	2 from 4	

EDCON-COMPONENTS

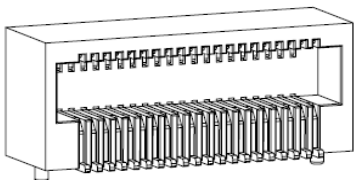

Ordering Informations

Serie	No. of Pos.	Construction	Contact Plating	Material	Polarisation Peg	Special function	Special function	ROHS	Packing
T15F001	xx	F	G0	PA	Y	N	N	R	TR

XX = like Pos. Table		G0 = Gold Flash		Y = Yes	00 = No special function	00 = No special function	R =ROHS conform	
	F = Female						N =NO ROHS conform	TC = Tube with Cap
			PA = PA9T					
								TR = Tape Reel Packing w. Cap

Board to Board Connector Pitch 0,50mm
Part No.: T15F001
Customer:

DRW:	Jason	CHKD	Wilson	MATL:	Wilson	TOLERANCE	Mason	DATE	02.10.2021
APPD:	Schumi			FINISH	Jamy		Sheet No.		3 from 4

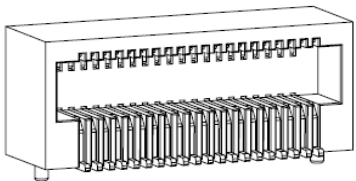

Soldering Profile for Lead Soldering

Soldering Profile for Lead Free Soldering

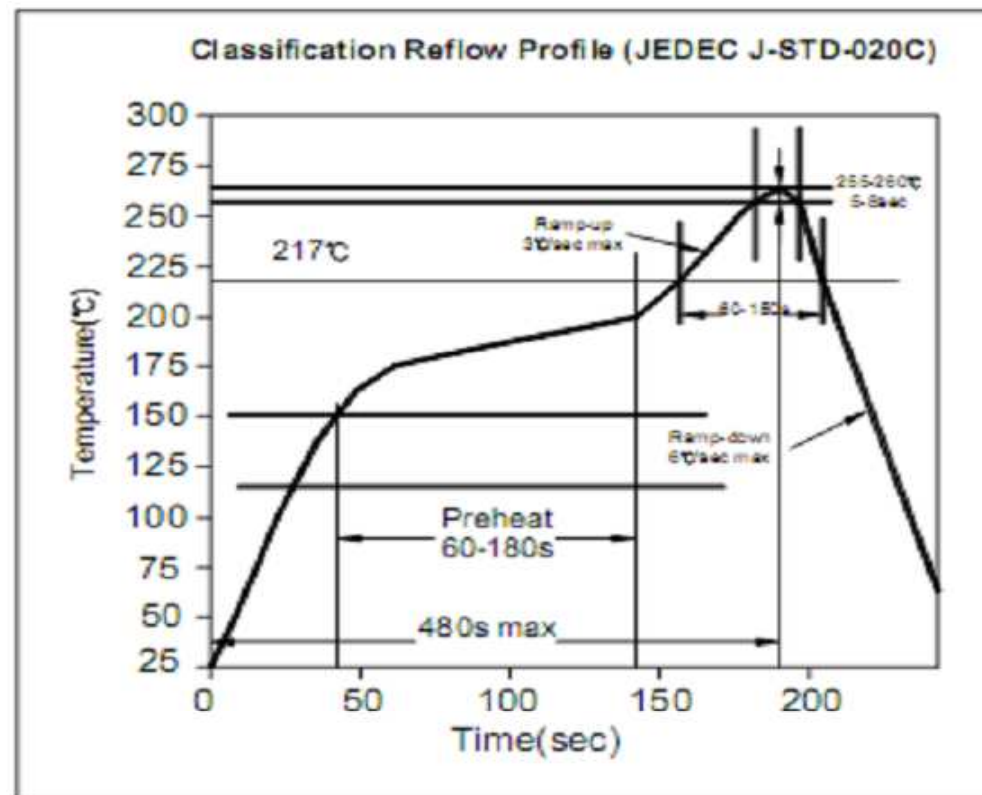
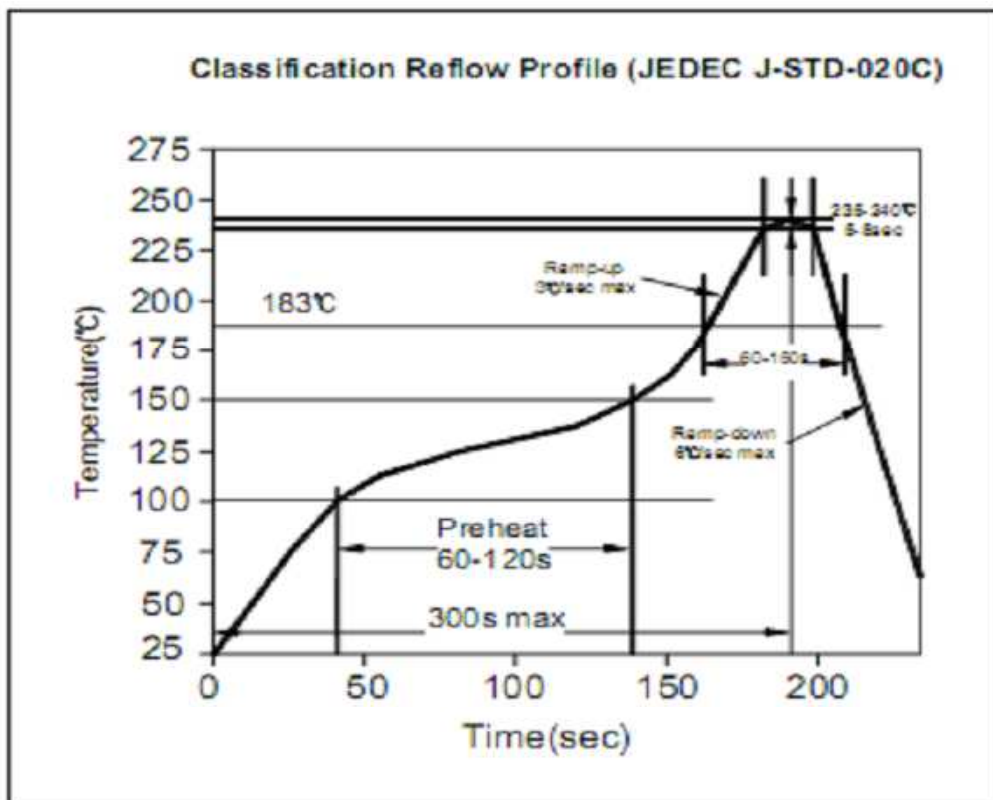

**Board to Board Connector
Pitch 0,50mm**

Part No.: **T15F001**

DRW:	Jason	CHKD	Wilson	MATL:	Wilson	TOLERANCE	Mason	DATE	02.10.2021
APPD:	Schumi			FINISH	Jamy		Sheet No.	4 from 4	Customer: