

EDCON-COMPONENTS

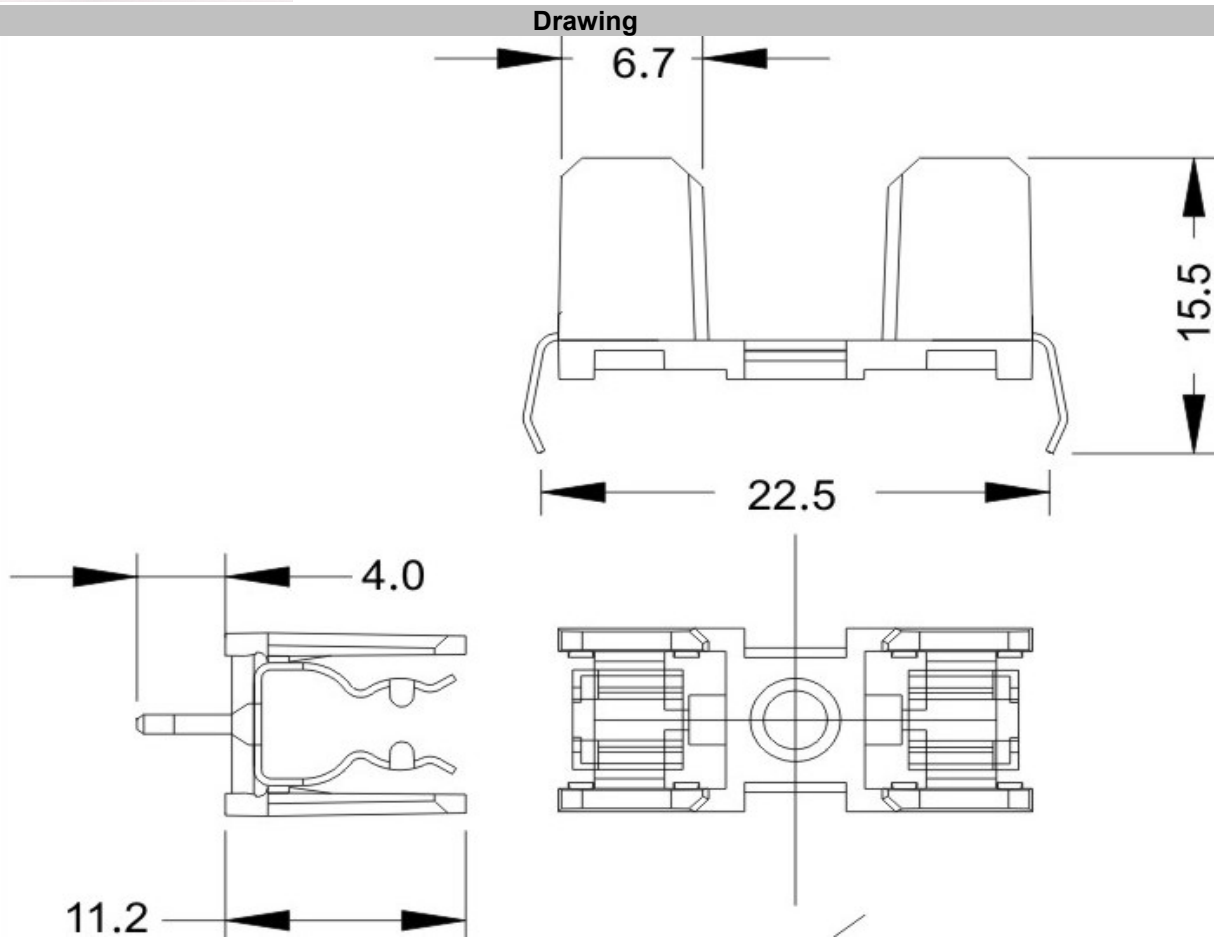

Drawing



Technical Description

Fuse-Type	Glass / Ceramic
Fuse:	5,2x20mm
Rated Current:	max ~ 10A
Rated Voltage:	250VAC
Material Cap:	PC
Cap:	Bajonet Type Cap
Material Terminal	Brass tin plated
Material:	P.B.T
Soldering Temperature:	240°C
Approval:	

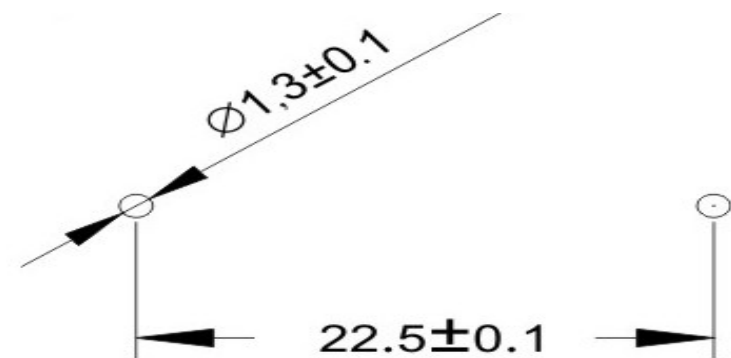

Faston Fuse Holder 6,3x32mm

Part No.: **R53097**

DRW:	Jason	CHKD	Wilson	MATL:	Wilson	TOLERANCE	Mason	DATE	10.03.2026
APPD:	Schumi			FINISH	Jamy		Sheet No.		1 from 3

Customer:

www.edcon-components.com

email: info@edcon-components.com

EDCON-COMPONENTS



Ordering Informations

Serie	Spezial Function	Spezial Function	ROHS	Packing						
R53097	0	0	R	BU						

0 = No function	0 = No function	R = ROHS Conform	BU = Bulk-Ware

Faston Fuse Holder 6,3x32mm
Part No.: R53097
Customer:

DRW:	Jason	CHKD	Wilson	MATL:	Wilson	TOLERANCE	Mason	DATE	10.03.2026
APPD:	Schumi			FINISH	Jamy		Sheet No.	2 from 3	



Soldering Profile Curve

Classification Reflow Profile (JEDEC J-STD-020C)

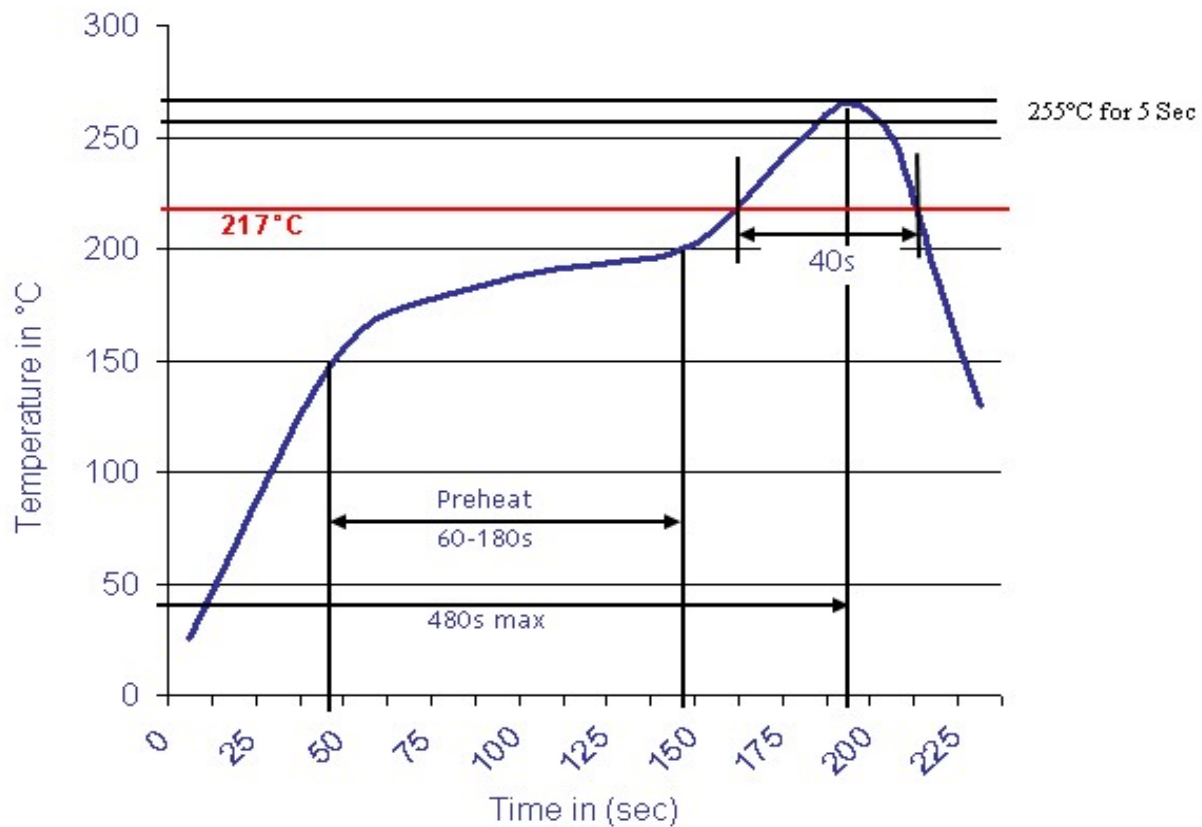

Faston Fuse Holder 6,3x32mm	
Part No.:	R53097
Customer:	

DRW:	Jason	CHKD:	Wilson	MATL:	Wilson	TOLERANCE:	Mason	DATE:	10.03.2026
APPD:	Schumi	FINISH:	Jamy			Sheet No.:			3 from 3