



# DATA SHEET

## PCB Reed Relay 19,8x7,5x5mm

### Serie: P16001

**PCB Reed Relay  
19,8x7,5x5mm**

Serie No.: **P16001**

Customer:

DRW:	Jason	CHKD	Wilson	MATL:	Wilson	TOLERANCE	Mason	DATE	03.12.2011
APPD:	Schumi			FINISH	Jamy		Sheet No.		1 from 7

# EDCON-COMPONENTS



## Technical Informations

### Features

Flat type micro reed relay with low height 7,5mm  
 high mounting density on PC Boards  
 High capacity type (10VA max.) switch current of 0,5A  
 Capable of stable switching as minute a load DC1/10mA  
 Communications domestic appliances, Security equipments,  
 Office automation machines etc.

Contact Form:	1A
Contact Ratings:	0,1A / 100VAC, 0,1A/100VDC 0,5A / 20VAC , 0,5A/20VDC
Max. Switching Voltage:	AC110V, DC20VDC
Max Switching Current:	0,5A
Min. Switching Load:	DC1V, 1mA
Life Expectancy Electrical	1x10 <sup>7</sup> (at 6VDC/10mA) 2x10 <sup>6</sup> (at Rated Load)
Life Expectancy Mechanical:	1x10 <sup>8</sup>

### General technical Data

Insulation Resistance	100Ω min at (500VDC)
Dielectric Strength Between Coil and Contacts	1000VAC 50~60Hz ( 1minute)
Dielectric Strength Between Contacts	250VAC 50~60Hz ( 1minute)
Operating time	0,5ms
Release time	0,5ms
Ambient Temperature	. -40°C ~ +85°C
Shock Resistance	100g
Vibration Resistance	10-55Hz, 1,5mm double amplitude
Ambient humidity	45~85% RH
Weight	Approx 3gr.

### PCB Reed Relay 19,8x7,5x5mm

Part No.: **P16001**

Customer:

DRW:	Jason	CHKD	Wilson	MATL:	Wilson	TOLERANCE	Mason	DATE	03.12.2011
APPD:	Schumi			FINISH	Jamy		Sheet No.		2 from 7

# EDCON-COMPONENTS



## Technical Dimensions

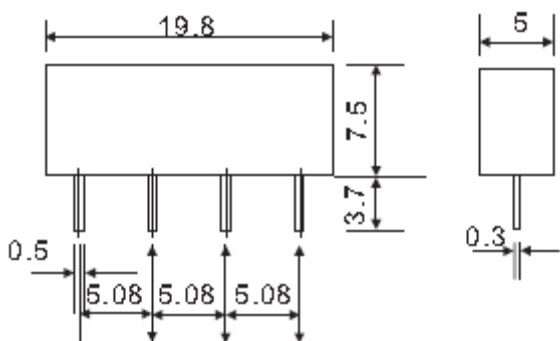

Unshielded Narrow Type (UN)

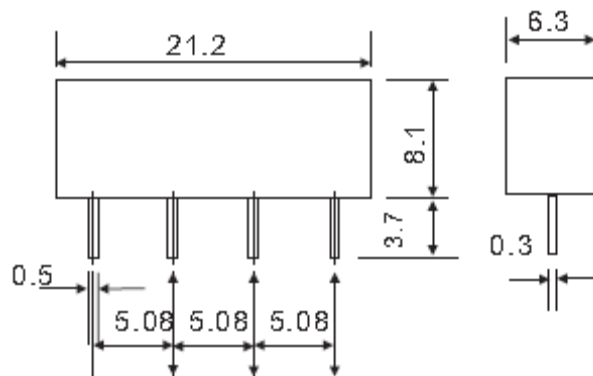

Shielded Narrow Type (SN)

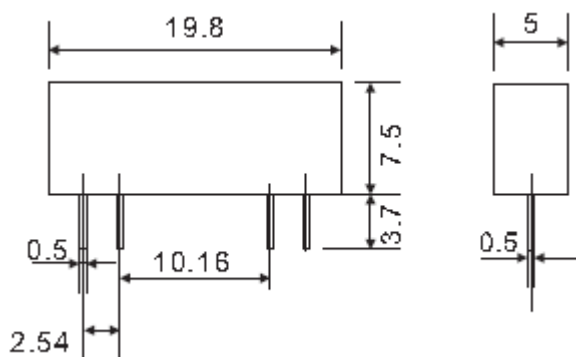

Unshielded Wide Type (UW)

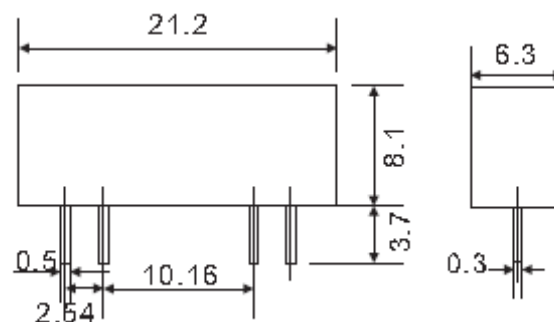

Shielded Wide Type (SW)

<b>PCB Reed Relay 19,8x7,5x5mm</b>	
Part No.:	<b>P16001</b>
Customer:	

DRW:	Jason	CHKD	Wilson	MATL:	Wilson	TOLERANCE	Mason	DATE	03.12.2011
APPD:	Schumi			FINISH	Jamy		Sheet No.	3 from 7	

# EDCON-COMPONENTS



## PCB Mounting (Bottom View)

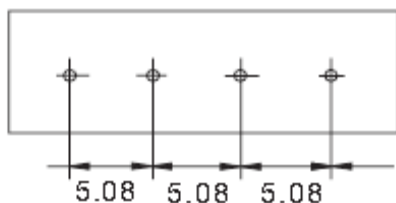

Narrow Type (N)

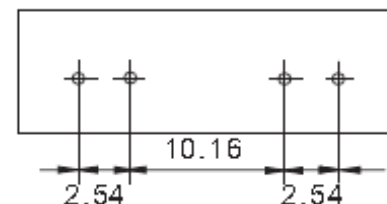

Wide Type (W)

## Coil Voltage + Parameter

Rated Voltage (VDC)	Coil Voltage		Coil Resistance $\Omega$ ( $\pm 10\%$ ) @20°C			Pickup Voltage (VDC)	Release Voltage (VDC)	Nominal Current (mA)	Power Consumption (mW)
	Rated	Max.							
003	3	3,9		100		75% max.	10% Min.	5	10
005	5	6,5		500		75% max.	10% Min.	10	16
012	12	15,6		1000		75% max.	10% Min.	12	26
024	24	31,2		2000		75% max.	10% Min.	12	32

**PCB Reed Relay  
19,8x7,5x5mm**

Part No.: **P16001**

DRW:	Jason	CHKD	Wilson	MATL:	Wilson	TOLERANCE	Mason	DATE	03.12.2011	Customer:
APPD:	Schumi			FINISH	Jamy		Sheet No.	4 from 7		

# EDCON-COMPONENTS



## Wiring Diagramm

## Approvals

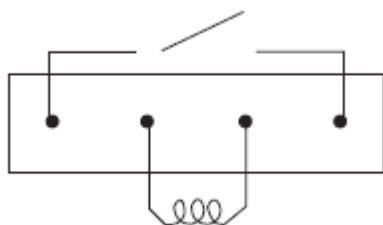

without Diode (N)

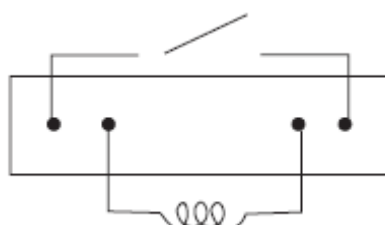

without Diode (N)

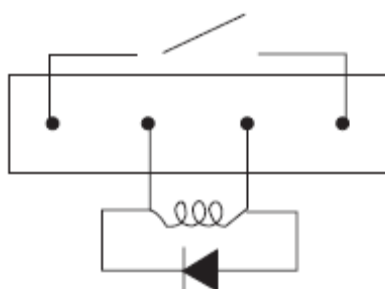

with Diode (D)

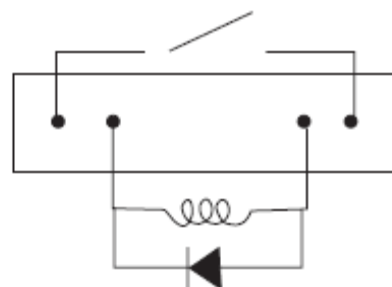

with Diode (D)

Safety Approvals	UL & UR	VDE	TÜV
	pending	NO	NO

Safety Approvals	CQC		
	NO		

<b>PCB Reed Relay 19,8x7,5x5mm</b>	
Part No.:	<b>P16001</b>
Customer:	

DRW:	Jason	CHKD	Wilson	MATL:	Wilson	TOLERANCE	Mason	DATE	03.12.2011
APPD:	Schumi			FINISH	Jamy		Sheet No.	5 from 7	

# EDCON-COMPONENTS



## Ordering Informations

Serie	Rated Coil Voltage	Coil Type DC/AC	Contact Form	Cover	Contact Spacing	Diode	ROHS	Packing Code	
-------	--------------------	-----------------	--------------	-------	-----------------	-------	------	--------------	--

<b>P16001</b>	-	<b>012</b>	<b>DC</b>	<b>1A</b>	<b>U</b>	<b>N</b>	<b>D</b>	<b>R</b>	<b>TU</b>
---------------	---	------------	-----------	-----------	----------	----------	----------	----------	-----------

<b>012=</b> 12 Volt	<b>DC=</b> DC Voltage	<b>1A=</b> Form 1A	<b>U=</b> Unshielded	<b>N=</b> Narrow	<b>N=</b> w/o Diode	<b>R=</b> ROHS Conform	<b>TU=</b> Tube Packing
			<b>S=</b> Shielded	<b>W=</b> Wide	<b>D=</b> with Diode	<b>N=</b> NON ROHS Conform	<b>TY=</b> Tray Packing

<b>PCB Reed Relay 19,8x7,5x5mm</b>	
Part No.:	<b>P16001</b>
Customer:	

DRW:	Jason	CHKD	Wilson	MATL:	Wilson	TOLERANCE	Mason	DATE	03.12.2011
APPD:	Schumi			FINISH	Jamy		Sheet No.	6 from 7	



Soldering Profile Curve

Classification Reflow Profile (JEDEC J-STD-020C)

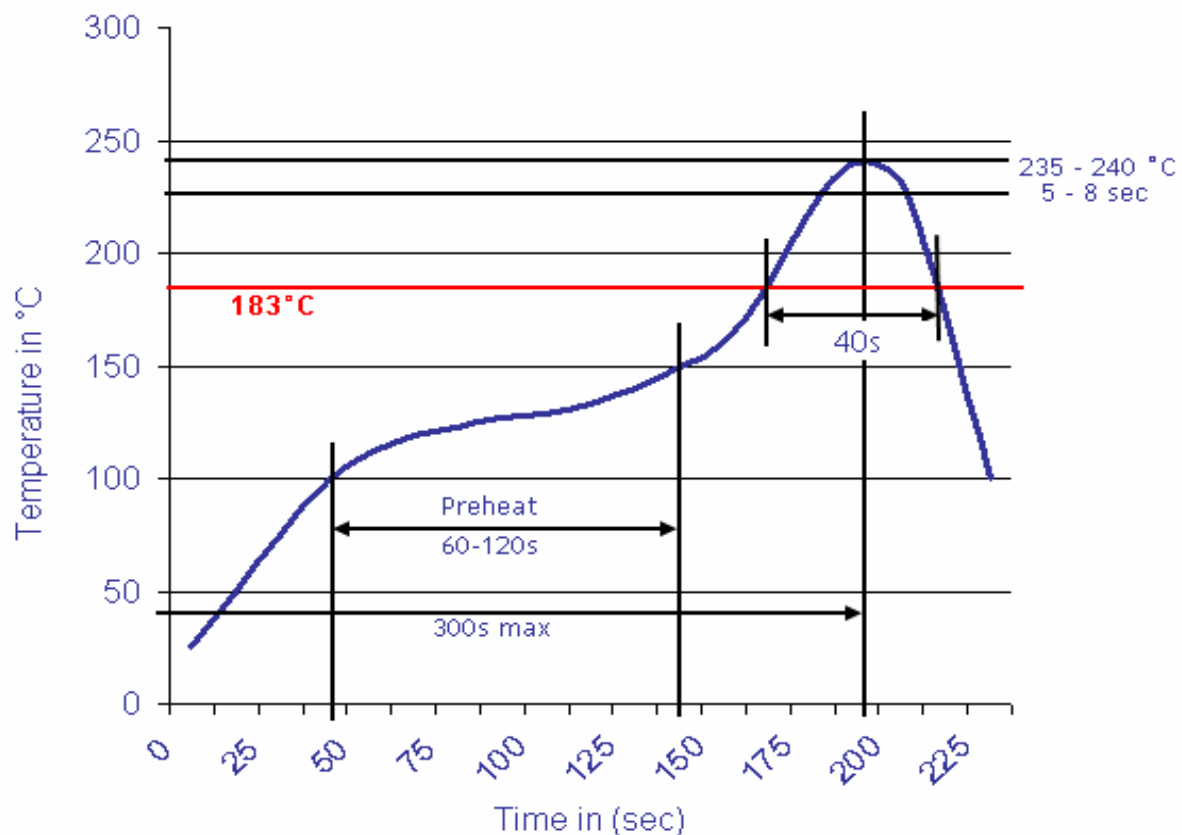

<b>PCB Reed Relay 19,8x7,5x5mm</b>	
Part No.:	<b>P16001</b>
Customer:	

DRW:	Jason	CHKD	Wilson	MATL:	Wilson	TOLERANCE	Mason	DATE	03.12.2011
APPD:	Schumi			FINISH	Jamy		Sheet No.	7 from 7	