

EDCON-COMPONENTS

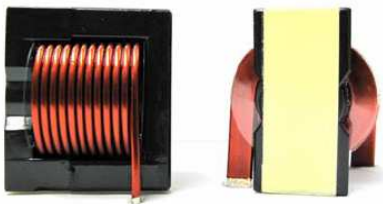

Technical Discription

Designed for flat helix winding coil high curent high volt *time applications
 Lowest DCR, lower loss reduce size, high efficiency, less Temperature
 Winding to core isolation is 500 Vrms
 Inductance tested at 500KHz, 0,1Vrms
 DC current at which the inductance drops. The specified amount from ist without current.
 Winding: temperature rise = 130°C max.
 Operating temperature range -25°C ~ +100°C
 Electrical specifications at 25°C
 Inductance tolerance ±20%

Range Informations

| | |
|---------------------|------|
| Inductance (µH) typ | 11,0 |
| . @ 0 ADC | 15,0 |
| . @ I sat | 11,0 |

| | |
|---------------|------|
| DCR (mΩ) max. | 1,5 |
| I sat (A DC) | 39,0 |

Drawing

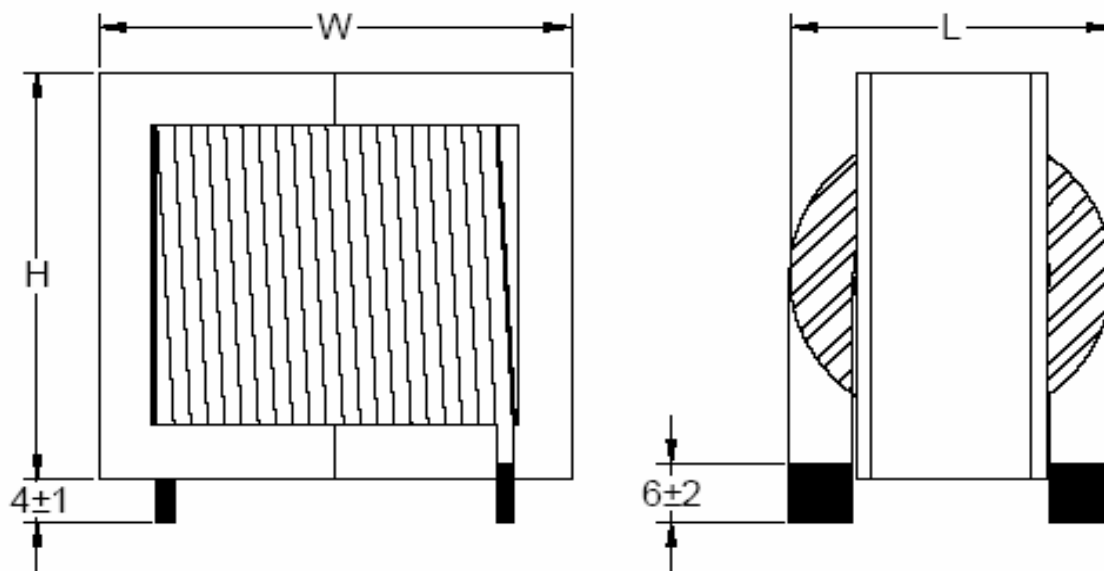

| Dimension (mm) | |
|----------------|------|
| L | 32,0 |
| W | 27,0 |
| H | 43,0 |

| PCB Hole Dimension | |
|--------------------|--|
| 2,3x7,5 mm | |

| | |
|-------------------------------------|---------------|
| FLAT WINDING HIGH POWER COIL | |
| Part No.: | S10R65 |

| | | | | | | | | | | |
|-------|--------|------|--------|--------|--------|-----------|-----------|----------|------------|-----------|
| DRW: | Jason | CHKD | Wilson | MATL: | Wilson | TOLERANCE | Mason | DATE | 12.09.2011 | Customer: |
| APPD: | Schumi | | | FINISH | Jamy | | Sheet No. | 1 from 3 | | |

EDCON-COMPONENTS

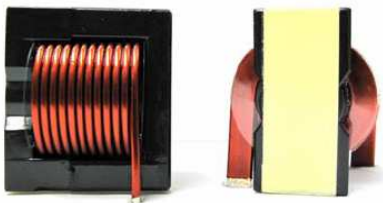

Ordering Informations

| Serie | Range Code | Tolerance Code | ROHS | Packing | | | | | | |
|-------|------------|----------------|------|---------|--|--|--|--|--|--|
|-------|------------|----------------|------|---------|--|--|--|--|--|--|

| | | | | | | | | | | |
|---------------|------------|----------|----------|-----------|--|--|--|--|--|--|
| S10R65 | 110 | M | R | TU | | | | | | |
|---------------|------------|----------|----------|-----------|--|--|--|--|--|--|

| | | | |
|------------------|----------------|------------------------|-------------------------|
| 110= 11µH | M= ±20% | R= ROHS Conform | TU= Tube Packing |
| | | | TY= Tray Packing |

| |
|-------------------------------------|
| FLAT WINDING HIGH POWER COIL |
| Part No.: S10R65 |
| Customer: |

| | | | | | | | | | |
|-------|--------|------|--------|--------|--------|-----------|-------|-----------|------------|
| DRW: | Jason | CHKD | Wilson | MATL: | Wilson | TOLERANCE | Mason | DATE | 12.09.2011 |
| APPD: | Schumi | | | FINISH | Jamy | | | Sheet No. | 2 from 3 |

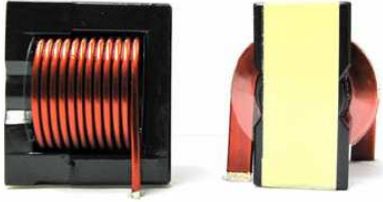

Soldering Profile Curve

Classification Reflow Profile (JEDEC J-STD-020C)

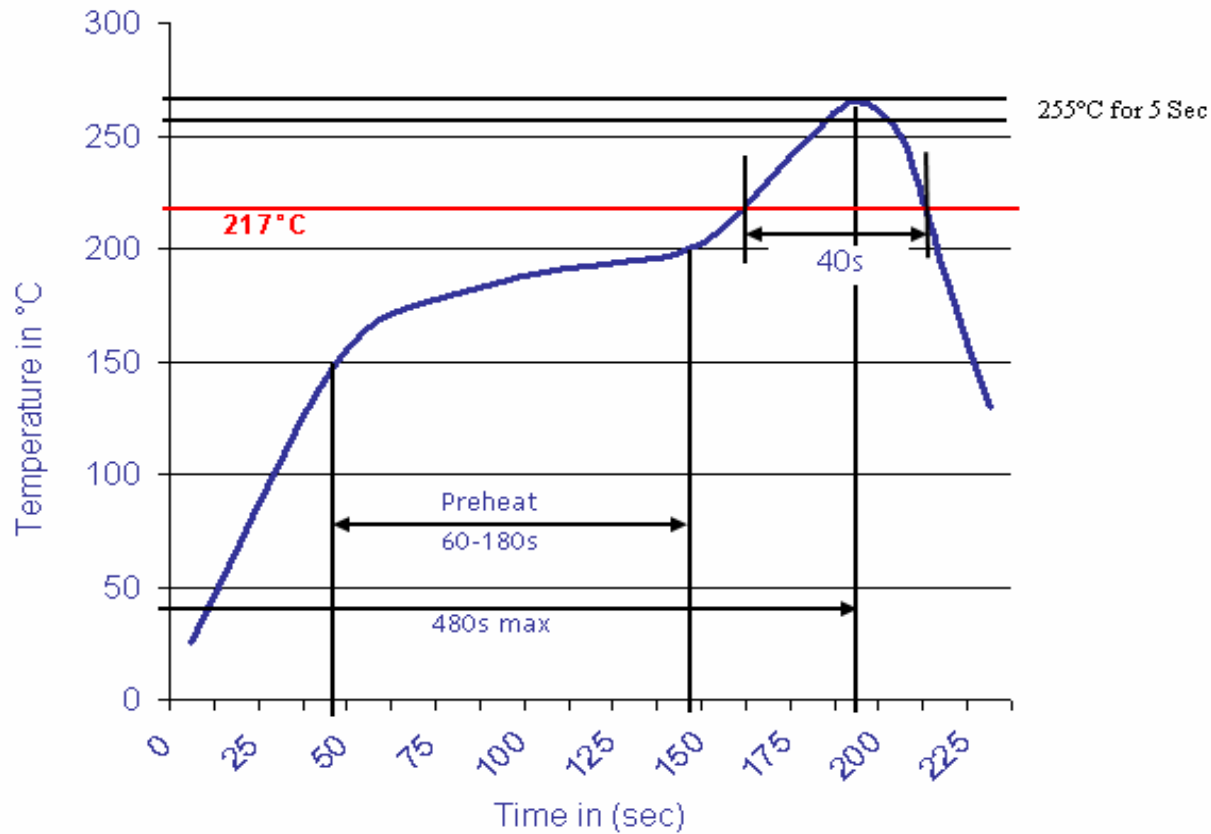

| | |
|-------------------------------------|---------------|
| FLAT WINDING HIGH POWER COIL | |
| Part No.: | S10R65 |
| Customer: | |

| | | | | | | | | | |
|-------|--------|------|--------|--------|--------|-----------|-----------|------|------------|
| DRW: | Jason | CHKD | Wilson | MATL: | Wilson | TOLERANCE | Mason | DATE | 12.09.2011 |
| APPD: | Schumi | | | FINISH | Jamy | | Sheet No. | | 3 from 3 |

www.edcon-components.com

email: info@edcon-components.com