

EDCON-COMPONENTS



Technical Discription

Designed for flat helix winding coil high curent high volt *time applications
 Lowest DCR, lower loss reduce size, high efficiency, less Temperature
 Winding to core isolation is 500 Vrms
 Inductance tested at 500KHz, 0,1Vrms
 DC current at which the inductance drops. The specified amount from ist without current.
 Winding: temperature rise = 130°C max.
 Operating temperature range -25°C ~ +100°C
 Electrical specifications at 25°C
 Inductance tolerance ±20%

Range Informations

Inductance (µH) typ	65,0
. @ 0 ADC	72,0
. @ I sat	65,0

DCR (mΩ) max.	18,0
I sat (A DC)	13,0

Drawing

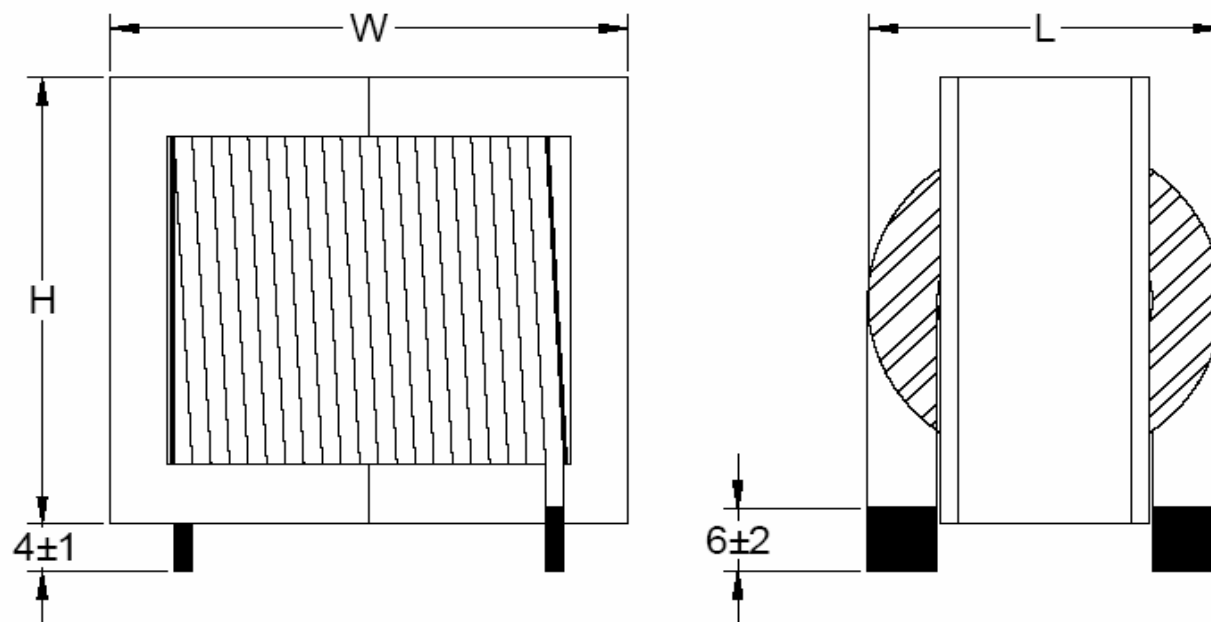

Dimension (mm)	
L	23,5
W	40,0
H	40,0

PCB Hole Dimension	
1,4x5,5 mm	

FLAT WINDING HIGH POWER COIL

Part No.: **S10R64**

DRW:	Jason	CHKD	Wilson	MATL:	Wilson	TOLERANCE	Mason	DATE	12.09.2011	Customer:
APPD:	Schumi			FINISH	Jamy			Sheet No.	1 from 3	

EDCON-COMPONENTS



Ordering Informations

Serie	Range Code	Tolerance Code	ROHS	Packing						
-------	------------	----------------	------	---------	--	--	--	--	--	--

S10R64	650	M	R	TU						
---------------	------------	----------	----------	-----------	--	--	--	--	--	--

650 = 65μH	M = ±20%	R = ROHS Conform	TU = Tube Packing
			TY = Tray Packing

FLAT WINDING HIGH POWER COIL
Part No.: S10R64
Customer:

DRW:	Jason	CHKD	Wilson	MATL:	Wilson	TOLERANCE	Mason	DATE	12.09.2011
APPD:	Schumi			FINISH	Jamy		Sheet No.	2 from 3	



Soldering Profile Curve

Classification Reflow Profile (JEDEC J-STD-020C)

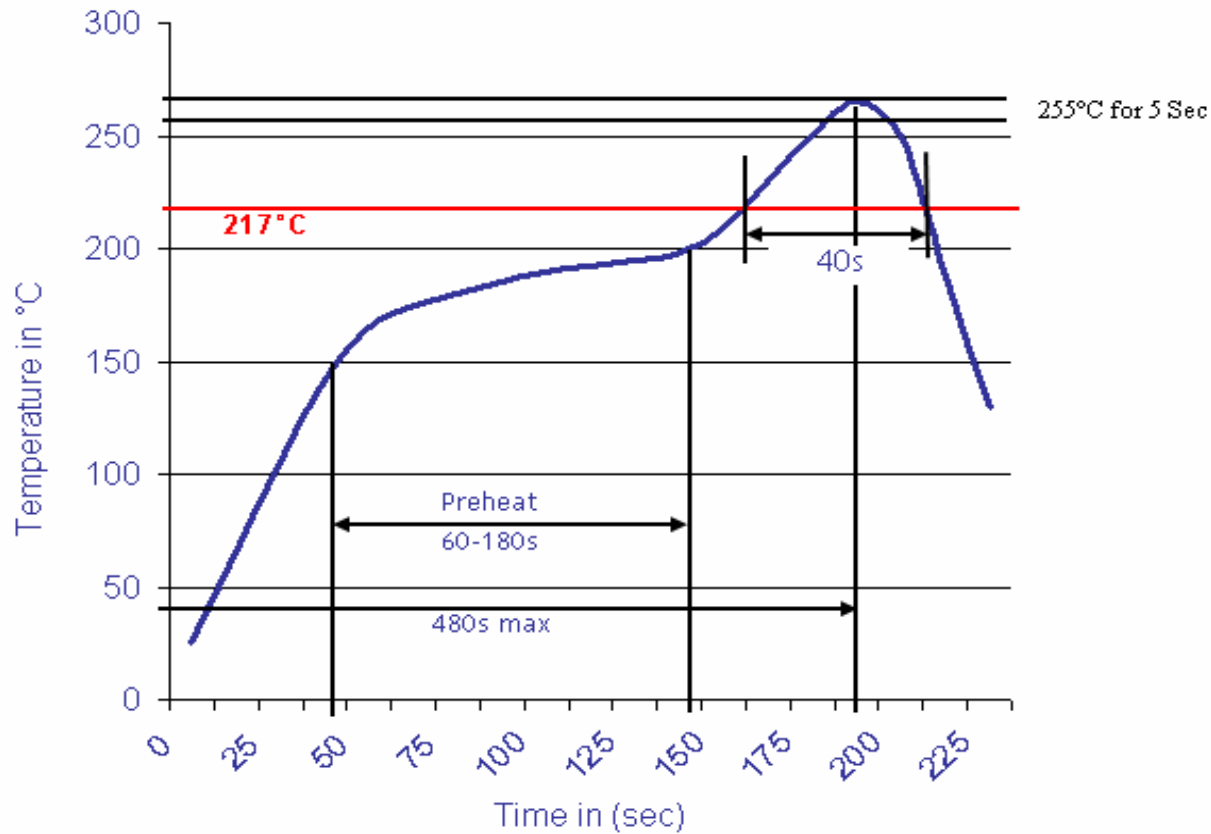

FLAT WINDING HIGH POWER COIL	
Part No.:	S10R64
Customer:	

DRW:	Jason	CHKD	Wilson	MATL:	Wilson	TOLERANCE	Mason	DATE	12.09.2011
APPD:	Schumi			FINISH	Jamy		Sheet No.		3 from 3

www.edcon-components.com

email: info@edcon-components.com