

EDCON-COMPONENTS



Application

EDCON-COMPONENTS Serie C11 Changeover switch is the load breaking switch to be used control main circuit, auxillary circuit and three phases motor and other loads. It is of hand operated switch, meet with standard IEC947-3/DIN VDE0600 (EN60947-3), release the isolation as well. The switch is used to strat/stop (ON/OFF) urgent stop.

Technical Parameters

Rated Insulation Voltage (V)	690V		
Rated thermal current (A)	25A		
AC-201A / AC21A (A)	25A		
AC-22A (A)	20A		
Rated operating Voltage	220	380	500
AC-3 (KW)	3	5,5	5,5
AC-23 (KW)	4	7,5	7,5

Drawing for Panel Mount

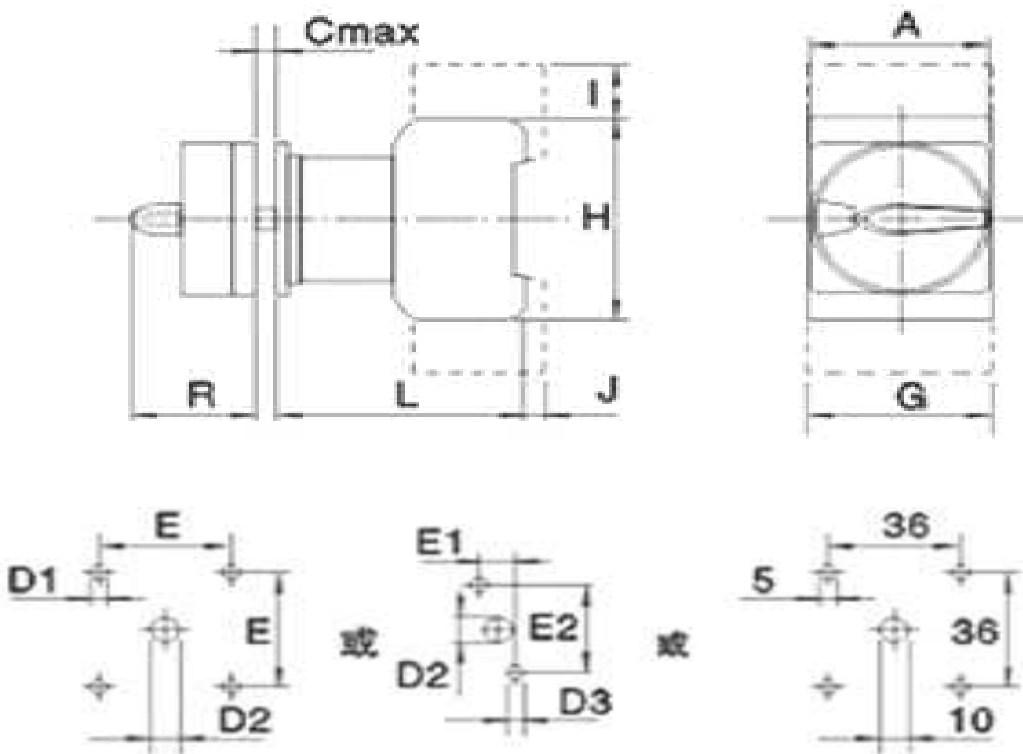

Dimension (mm)

Type	E	E1	E2	D1	D2	D3	A	L	H	I	G	J	R	Cmax.
Q69001	48	12,2	30	5	10~15	3,5	64	53,8	54	20	42	6	40,1	4

Changeover Switch 25A

Part No.: **Q69001**

DRW:	Jason	CHKD	Wilson	MATL:	Wilson	TOLERANCE	Mason	DATE	23.03.2011	Customer:
APPD:	Schumi			FINISH	Jamy		Sheet No.	1 from 2		

www.edcon-components.com

email: info@edcon-components.com

EDCON-COMPONENTS



Ordering Informations

Terminal

Serie	Special funtion	ROHS	Packing			
-------	-----------------	------	---------	--	--	--

Q69001	N	R	WC			
--------	---	---	----	--	--	--

N= No special function	R= ROHS Conform	WC= White Carton
	N= NON ROHS Conform	

Changeover Switch 25A

Part No.: **Q69001**

DRW:	Jason	CHKD	Wilson	MATL:	Wilson	TOLERANCE	Mason	DATE	23.03.2011	Customer:
APPD:	Schumi			FINISH	Jamy		Sheet No.	2 from 2		