



DATA SHEET

Y2 AC Ceramic Capacitor 250VAC

Serie: I22003

| | | |
|--------------|------------|-----------------------------|
| Mat. Code | E | Material: B= Y5P |
| Voltage Code | 251 | Voltage: 251= 250VAC |
| Range Code | 103 | Range: 103= 10000pf |

**Y2 AC Ceramic Capacitor
250VAC**

Serie No.: **I22003**

| | | | | | | | | | |
|-------|--------|------|--------|--------|--------|-----------|-----------|------|------------|
| DRW: | Jason | CHKD | Wilson | MATL: | Wilson | TOLERANCE | Mason | DATE | 01.11.2010 |
| APPD: | Schumi | | | FINISH | Jamy | | Sheet No. | | 1 from 13 |

Customer:

EDCON-COMPONENTS



Technical Specifications

| | |
|---|-----------------------------|
| Temperature Characteristics | Y5P and Y5U and Y5V |
| Capacitance Change of Temperature Coefficient | Y5P = $\pm 10\%$ |
| | Y5U = $\pm 20\% \sim -55\%$ |
| | Y5V = $\pm 30\% \sim -80\%$ |
| Temperature Range: | -25°C ~ +85°C |
| Capacitance Tolerance: | K = $\pm 10\%$ |
| | M = $\pm 20\%$ |

Nominal Capacitance Code (Example)

| | |
|------|------------------|
| Code | Capacitance (pf) |
| 101 | 100 |
| 102 | 1000 |
| 222 | 2200 |
| 103 | 10000 |

Nominal capacitance shall consist of three numbers in the unit of picofard(pf). The first and the second numbers mean the significant figures and the third number shall present the number of zeros following the significant figures.

Lead Style Informations

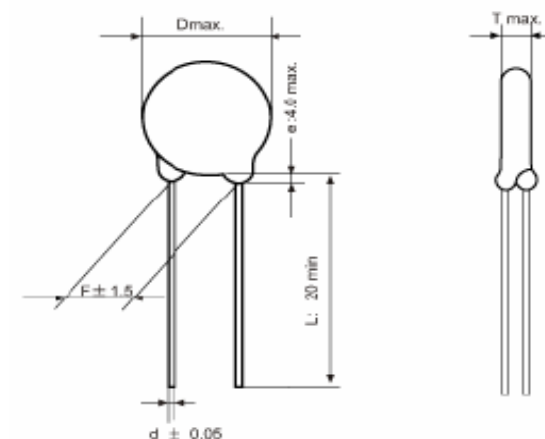

Lead Code Style (A) (mm)

| Pitch Code | A | B | C | D | E |
|------------|---------------------|-----|-----|----|------|
| F | 2,5 | 5,0 | 7,5 | 10 | 12,5 |
| L | only 20mm long lead | | | | |
| d | 0,5 or 0,6 or 0,8mm | | | | |
| e | max. 4,0mm | | | | |

**Y2 AC Ceramic Capacitor
250VAC**

Part No.: **I22003**

| | | | | | | | | | |
|-------|--------|------|--------|--------|--------|-----------|-----------|------|------------|
| DRW: | Jason | CHKD | Wilson | MATL: | Wilson | TOLERANCE | Mason | DATE | 01.11.2010 |
| APPD: | Schumi | | | FINISH | Jamy | | Sheet No. | | 2 from 13 |

Customer:

EDCON-COMPONENTS



Lead Style Informations

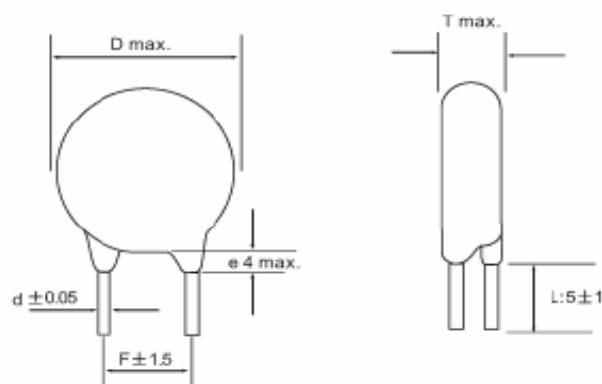

Lead Style Informations

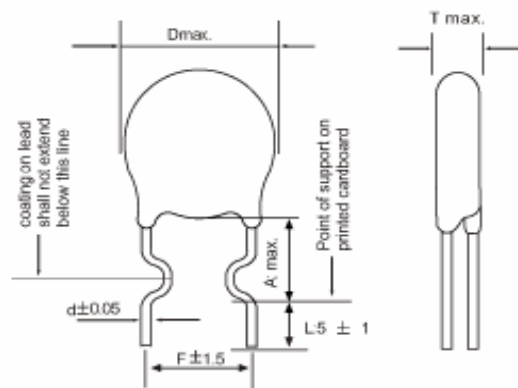

Lead Style Informations



Lead Code Style (B) Unit (mm)

| Pitch Code | A | B | C | D | E |
|------------|------------------------------|-----|-----|----|------|
| F | 2,5 | 5,0 | 7,5 | 10 | 12,5 |
| L | 5,0mm or on customer request | | | | |
| d | 0,5 or 0,6 or 0,8mm | | | | |
| e | max. 4,0mm | | | | |

Lead Code Style (C) Unit (mm)

| Pitch Code | B | C | D | E |
|------------|------------------------------|-----|-----|------|
| F | 5,0 | 7,5 | 10 | 12,5 |
| A | 5,0 | 5,0 | 6,5 | 6,5 |
| L | 5,0mm or on customer request | | | |
| d | 0,5 or 0,6 or 0,8mm | | | |

Lead Code Style (D) Unit (mm)

| Pitch Code | B | C | D | E |
|------------|---------------------|-----|-----|------|
| F | 5,0 | 7,5 | 10 | 12,5 |
| A | 5,0 | 5,0 | 6,5 | 6,5 |
| L | 20mm min. | | | |
| d | 0,5 or 0,6 or 0,8mm | | | |

Y2 AC Ceramic Capacitor 250VAC

Part No.: **I22003**

| | | | | | | | | | |
|-------|--------|------|--------|--------|--------|-----------|-----------|------|------------|
| DRW: | Jason | CHKD | Wilson | MATL: | Wilson | TOLERANCE | Mason | DATE | 01.11.2010 |
| APPD: | Schumi | | | FINISH | Jamy | | Sheet No. | | 3 from 13 |

Customer:
email: info@edcon-components.com

EDCON-COMPONENTS



Lead Style Informations

Lead Style Informations

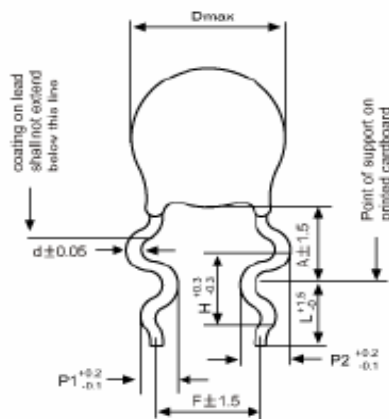

Lead Code Style (H) Unit (mm)

| Pitch Code | B | C | D | E |
|------------|------------------------------|-----|----|------|
| F | 5,0 | 7,5 | 10 | 12,5 |
| L | 5,0mm or on customer request | | | |
| d | 0,5 or 0,6 or 0,8mm | | | |

Lead Code Style (M) Unit (mm)

| Pitch Code | B | C | D | E |
|------------|------------------------------|------|------|------|
| F | 5,0 | 7,5 | 10 | 12,5 |
| H | 2,6 | 2,6 | 3,3 | 3,3 |
| P1 | 1,3 | 1,25 | 1,65 | 1,65 |
| P2 | 1,65 | 1,65 | 1,95 | 1,95 |
| A | D<8: 6,0± 1,5, D>8: 7,0± 1,5 | | | |
| L | 3,0 ~ 30mm | | | |
| d | 0,5 or 0,6 or 0,8mm | | | |

**Y2 AC Ceramic Capacitor
250VAC**

Part No.: **I22003**

| | | | | | | | | | |
|-------|--------|------|--------|--------|--------|-----------|-----------|-----------|------------|
| DRW: | Jason | CHKD | Wilson | MATL: | Wilson | TOLERANCE | Mason | DATE | 01.11.2010 |
| APPD: | Schumi | | | FINISH | Jamy | | Sheet No. | 4 from 13 | Customer: |

www.edcon-components.com

email: info@edcon-components.com

EDCON-COMPONENTS



Specification and test method

Operating Temperature range -25°C ~ +105°C
 But temperature range is -25% ~ +85°C at safety standard specification.

Test and measurement shall be made at the standard condition.
 (Temperature 15 ~ 35°C relative humidity 45 ~ 75% and atmospheric pressure 860~1060hpa). Unless otherwise specified herein it doubt accurated on the value of measurement, and remesurement was requested by customer capacitor shall be measured at the reference condition (Temperature 20 ±2°C, relative humidity 60~70% and atmospheric pressure 860~1060hpa). unless otherwise specified herein.

Leakage Current Characteristics

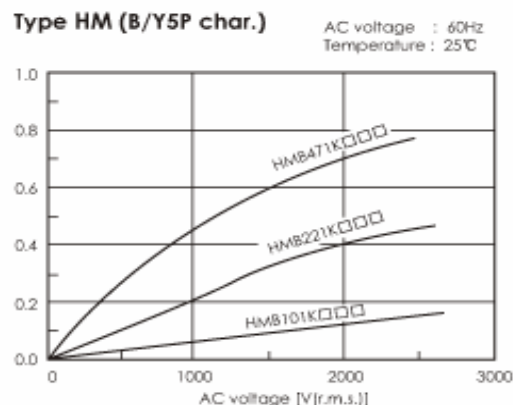

Capacitance Temperature Characteristics

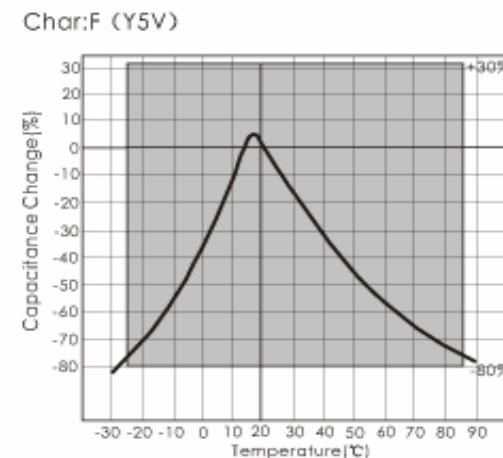

Impedance vs. Frequency Characteristics

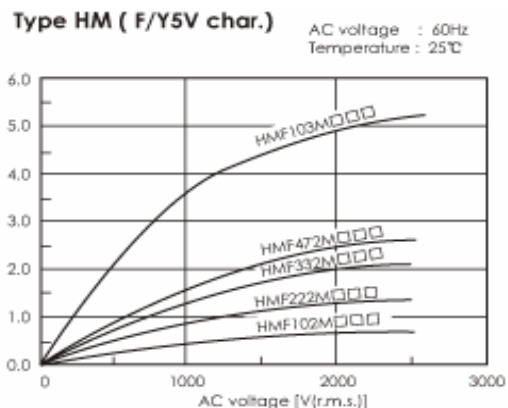
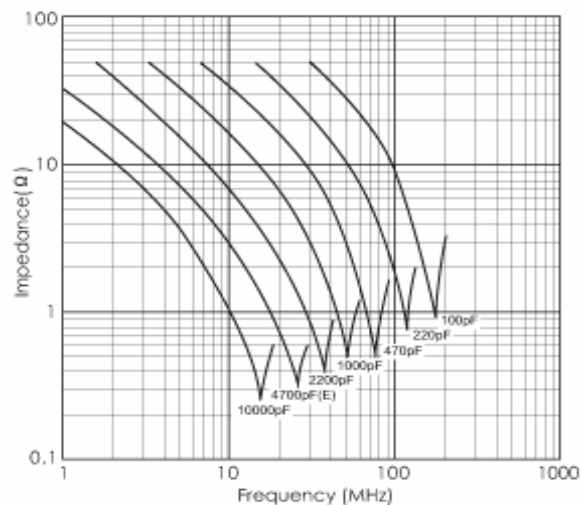

Char: B (Y5P)

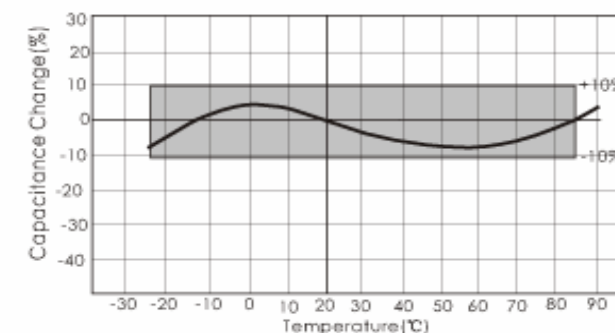

**Y2 AC Ceramic Capacitor
250VAC**

Part No.: **I22003**

Customer:

| | | | | | | | | | |
|-------|--------|------|--------|--------|--------|-----------|-----------|-----------|------------|
| DRW: | Jason | CHKD | Wilson | MATL: | Wilson | TOLERANCE | Mason | DATE | 01.11.2010 |
| APPD: | Schumi | | | FINISH | Jamy | | Sheet No. | 5 from 13 | |

EDCON-COMPONENTS

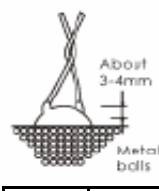

| Item | Specification | Testing Method |
|---------------------------|---|---|
| Appearance and Dimensions | No marked defect on appearance from and dimension are within specified range. | The capacitor shall be inspected by naked eyes for visible evidence of defect. Dimensions shall be measured with slide calipers. |
| Marking | To be easily legible. | The capacitor shall be inspected by naked eyes |
| Capacitance | Within specified tolerance | The capacitance, dissipation shall be measured at $25 \pm 2^\circ\text{C}$ with $1 \pm 0,1\text{KHz}$ and $\text{AC}1 \pm 0,1\text{V}$ (r.m.s) |
| Dissipation Factor (D,F) | Char. Specification | |
| | B, E= D,F= $\leq 2,5\%$ F= D,F= $\leq 5,0\%$ | |
| Insulation Resistance (R) | 10000M Ω min. | The insulation resistance shall be measured with DC $500 \pm 50\text{V}$ within $60 \pm 5\text{sec}$. Of charging. |
| Dielectric Strength | Between Lead wires | No failure The capacitor shall not be damage when AC 2600V (r.m.s.) are applied between the lead wires for 60s. |
| | Body Insulation | No failure First, the terminals of the capacitor shall be connected together. Then as shown in Figure right, a metal foil shall be closely wrapped around the body of the capacitor to the distance of about 3-4mm from each terminal. Then the capacitor shall be inserted into a container filled with balls of about 1mm diameter. Finally AC 2600V (r.m.s.) is applied for 60s between the capacitor lead wires and metal balls.  |

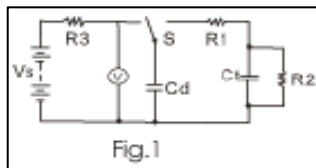
| Item | Specification | Testing Method | | |
|-----------------------------|---|--|--|----------------------------------|
| Temperature Characteristics | Char. Capacitance Change | The capacitance measurement shall be made of each step specified in table 3. | | |
| | B | within $\pm 10\%$ | Step | Temperature ($^\circ\text{C}$) |
| | E | within $+ 20\% -55\%$ | 1 | $\pm 20 \pm 2$ |
| | F | within $+ 30\% -80\%$ | 2 | $- 25 \pm 2$ |
| | Temperature characteristics guarantee is -25 to $+85^\circ\text{C}$ | | 3 | $\pm 20 \pm 2$ |
| | | 4 | $\pm 85 \pm 2$ | |
| | | 5 | $\pm 20 \pm 2$ | |
| Discharge test (1) | Appearance | No marked defect. | As in figure , discharge in made 50 times at 5sec intervals from the capacitor (Cd) charged at DC voltage of specified  Fig.1 | |
| | I.R. | 1000M Ω min. | | |
| | Dielectric Strength | per Item 6. | | |

**Y2 AC Ceramic Capacitor
250VAC**

Part No.: **I22003**

Customer:

| | | | | | | | | | |
|-------|--------|------|--------|--------|--------|-----------|-----------|------|------------|
| DRW: | Jason | CHKD | Wilson | MATL: | Wilson | TOLERANCE | Mason | DATE | 01.11.2010 |
| APPD: | Schumi | | | FINISH | Jamy | | Sheet No. | | 6 from 13 |

EDCON-COMPONENTS



| Item | Specification | Testing Method | Item | Specification | Testing Method | | | | | |
|----------------------|---|--|---|---|--|-----------|-------|-----------|------------|-----------|
| Discharge Trest II | The cheese-cloth around capacitors shall not glow or flame. | <p>A single layer of cheese cloth is to be placed around the body of the test capacitor. Each sample is to be subjected to four discharges from a dump capacitor charged to a voltage that. When discharged, placed DC 5KV across the capacitor under test. The interval between successive discharge is to be 5s. AC240V (r.m.s.)-60Hz potential is to applied across the capacitor under test and is to be maintained for 30s. after the fourth discharge, unless the circuit is opened in a shorter time by breakdown of the capacitor. The direct current supply is to be adjusted to provide a potential in accordance with the following.</p> <div style="text-align: center;"> $V_{dc} = \frac{5000(C_d + C_t)}{C_d} (V)$ <p>Fig.2</p> </div> <p>Vdc: Variable direct-current voltage source.</p> <p>s: High voltage switch</p> <p>L: Choke coil of appr. 3mH and 0,03Ω</p> <p>F: Plug fuse rated 30A and 250V</p> <p>Vac.: supply source rated 240V 60Hz 30A</p> <p>C1: Capacitor under test.</p> <p>Cd: Dump Capacitor</p> | Discharge Trest II | The cheese-cloth around capacitors shall not glow or flame. | Capacitance value and D.F. are follows. Cap. Value Cd to 0,005μF 0,0051 to 0,05μF Cap. Value CD 0,005μF 0,05μF D.F of Cd. 0,5% max. 0,5%max. | | | | | |
| | | | Solderability of leads | Lead wire shall be soldered with uniformly coated on the axial direction over 3/4 of the circumferential direction. | The lead wire of capacitor shall be dipped into molten solder of 235 ± 5°C for 2 ± 0,5s. The depth of immersion is up to about 1,5 to 2,0mm from the root of lead wires. | | | | | |
| Vibration Resistance | Apperance | No market defect Within the specified tolerance | D, F. | Char. B, E F | Specification D,F, ≤ 2,5% D,F, ≤ 5,0% | | | | | |
| | Capacitance | | | | | | | | | |
| | | | Y2 AC Ceramic Capacitor 250VAC | | | | | | | |
| | | | Part No.: I22003 | | | | | | | |
| DRW: | Jason | CHKD | Wilson | MATL: | Wilson | TOLERANCE | Mason | DATE | 01.11.2010 | Customer: |
| APPD: | Schumi | | | FINISH | Jamy | | | Sheet No. | 7 from 13 | |

EDCON-COMPONENTS

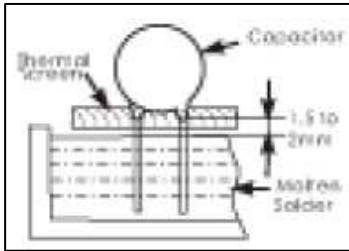

| Item | | Specification | Testing Method |
|------------------|---------------------|---------------------|--|
| Soldering Effect | Appearance | No marked defect | As in figure, the lead wires shall be immersed solder of $350 \pm 10^\circ\text{C}$ or $260 \pm 5^\circ\text{C}$ up to 1,5 ~ 2,0mm from the root of the terminal for $3,5 \pm 0,5\text{s}$. ($10 \pm 1\text{s}$ for $260 \pm 5^\circ\text{C}$). |
| | Capacitance change | Within $\pm 10\%$ | |
| | I.R. | 1000M Ω min. | |
| | Dielectric Strength | Pre Item 6. |  <p>Pre-treatment: Capacitor shall be stored at $85 \pm 2^\circ\text{C}$ for 1h. Then placed at room conditions for $24 \pm 2\text{h}$ before initial measurements.</p> <p>Post-treatment: Capacitor shall be stored for 1 to 2 h at room conditions.</p> |

| Item | | Specification | Testing Method | |
|--------------------------------|---------------------|--------------------------|--|--|
| Humidity (Under Steady State) | Appearance | No marked defect. | Set the capacitor for $500 \pm 12\text{h}$ at $40 \pm 2^\circ\text{C}$ in 90 ~ 95% relative humidity. Post-treatment: Capacitor shall be stored for 1 to 2h at room condition. | |
| | Capacitance Change | Char. Capacitance Change | | |
| | | B | | within $\pm 10\%$ |
| | D,F, | E,F | | within $\pm 15\%$ |
| | | Char. Specification | | |
| | | B,E | | D.F. $\leq 5,0\%$ |
| I.R. | F | D.F. $\leq 7,5\%$ | | |
| | 3000M Ω min. | | | |
| Dielectric Strength | Per Item 6 | | | |
| Humidity Loading | Appearance | No marked defect. | | Apply the rated voltage for $500 \pm 12\text{h}$ at $40 \pm 2^\circ\text{C}$ in 90 ~ 95% relative humidity. Post-treatment: Capacitor shall be stored for 1 to 2h at room condition. |
| | Capacitance Change | Char. Capacitance Change | | |
| | | B | within $\pm 10\%$ | |
| | D,F, | E,F | within $\pm 15\%$ | |
| | | Char. Specification | | |
| | | B,E | D.F. $\leq 5,0\%$ | |
| I.R. | F | D.F. $\leq 7,5\%$ | | |
| | 3000M Ω min. | | | |
| Dielectric Strength | Per Item 6 | | | |

**Y2 AC Ceramic Capacitor
250VAC**

Part No.: **I22003**

| | | | | | | | | | |
|-------|--------|------|--------|--------|--------|-----------|-----------|-----------|------------|
| DRW: | Jason | CHKD | Wilson | MATL: | Wilson | TOLERANCE | Mason | DATE | 01.11.2010 |
| APPD: | Schumi | | | FINISH | Jamy | | Sheet No. | 8 from 13 | Customer: |

EDCON-COMPONENTS



| Item | Specification | Testing Method |
|---------------------|---------------------|---|
| Life | Appearance | No marked defect. |
| | Capacitance Change | Within $\pm 20\%$ |
| | I.R. | 3000M Ω min. |
| | Dielectric Strength | Per Item 6. |
| Discharge Test (II) | Per Item 9. | <p>Impulse Voltage</p> <p>Each individual Capacity shall be subjected to 5KV impulses for three times. After the capacitance are supplied to life test.</p> <p>$T1 = 1.2 \mu s = 1.671$ $T2 = 50 \mu s$</p> <p>Apply a voltage of table 4 for 1000h at 105 $\pm 2/0^\circ C$, and relative humidity of 50% max. (table 4)</p> <p>Applied Voltage</p> <p>AC 425V (r.m.s.). Except that once each hour the voltage is increased to AC 1000V (r.m.s.) for 0,1s.</p> <p>Post-treatment: Capacitor shall be stored for 1 to 2h at room temperature.</p> |

| Item | Specification | Testing Method | |
|---------------------------|--|---|---|
| Flame Test | The capacitor flame discontinues as follows. | <p>The Capacitor shall be subjected to applied flame for 15s and then removed for 15 s until 5 cycle.</p> <p>Gas Burner (in mm)</p> | |
| | Cycle | | Time |
| | 1 to 4 | | 30s max. |
| 5 | 60s. Max | | |
| Robustness of Termination | Tensile | <p>Lead wire shall not cut off. Capacitor shall not be broken.</p> | |
| | Bending | | As a figure, fix the body of capacitor apply a tensile weight gradually to each lead wire in the radial direction of capacitor up to 10N and keep it for 10 \pm 1s. |
| Active Flammability | The chees-cloth shall not be on fire. | <p>Each lead wire shall be subjected to 5N weight and then a 90° bend, at the point of egress, in one direction, return to original position, and then a 90° bend in the opposite direction at the rate of one bend in 2 to 3s.</p> | |

**Y2 AC Ceramic Capacitor
250VAC**

Part No.: **I22003**

| | | | | | | | | | | |
|-------|--------|------|--------|--------|--------|-----------|-------|-----------|------------|-----------|
| DRW: | Jason | CHKD | Wilson | MATL: | Wilson | TOLERANCE | Mason | DATE | 01.11.2010 | Customer: |
| APPD: | Schumi | | | FINISH | Jamy | | | Sheet No. | 9 from 13 | |

EDCON-COMPONENTS



| Item | Specification | Testing Method | Item | Specification | Testing Method | | | | | |
|---------------------|--|--|----------------------|---|--|-----------|-------|-----------|------------|-----------|
| Active Flammability | The cheese-cloth shall not be on fire. | The capacitor shall be individually wrapped in at least one but more than two complete layers of cheese-cloth. The capacitor shall be subjected to 20 discharges. The interval between successive discharges shall be 5s. The UAC shall be maintained for 2min after the last discharge. | Passive Flammability | The burning time shall not be exceeded the time 30s. The tissue paper shall not ignite. | The capacitor under test shall be held in the flame in the position which best promotes burning. Each specimen shall only be exposed once to the flame. Time of exposure to flame: 30s. Length of flame: 12± 1mm. Gas burner: Length 35mm min. Inside Dia: 0,5 ± 0,1mm- Outside Dia. 0,9mm max. Gas: Butane gas Purity 95% min. | | | | | |
| | The cheese-cloth shall not be on fire | <p>C1,2: 1µF ±10% C3: 0,033µ ± 5% 10KV Ct: 3µF ± 5% 10KV Cx: Capacitor under test F: Fuse rated 10A L1 to 4: 1,5mH ± 20% 16A Rod core choke R: 100Ω ±2% UAC: UR ±5% UR: Rated Voltage Ut: Voltage applied to Ct</p> | | | | | | | | |
| DRW: | Jason | CHKD | Wilson | MATL: | Wilson | TOLERANCE | Mason | DATE | 01.11.2010 | Customer: |
| APPD: | Schumi | | | FINISH | Jamy | | | Sheet No. | 10 from 13 | |

**Y2 AC Ceramic Capacitor
250VAC**

Part No.: **I22003**

EDCON-COMPONENTS



| Item | | Specification | | Testing Method | | | | | | | |
|---|--------------------|------------------|---|---|------------------|-------------|-----------------|-------------------|--|--|--|
| Temperature and Immersion Style | Appearance | No marked defect | | The capacitor shall be subjected to 5 temperature cycles, then consecutively to 2 immersion cycles. | | | | | | | |
| | Capacitance Change | Char. | Capaci.Change | | | | | Temperature cycle | | | |
| | | B | Within ± 10% | | | | | | | | |
| | | E;F | Within ± 20% | Step | Temperature (°C) | Time | | | | | |
| | D.F. | | | 1 | . -25 +0/-3 | 30min | | | | | |
| | | Char. | Specification | 2 | Room temperature | 3min | | | | | |
| | | B;E | D.F. ≤ 5,0% | 3 | . + 105 +3/0 | 30min | | | | | |
| | | F | D.F. ≤ 7,5% | 4 | Room temperature | 3min | | | | | |
| | | | | Cycle time: 5cycle Immersion cycle | | | | | | | |
| | I.R. | 3000M Ω min. | | Step | Temperature (°C) | Time | Immersion Water | | | | |
| Dielectric Strength | Per Item 6 | | 1 | . +65 +/-0 | 15min | Clean Water | | | | | |
| | | | 2 | Room Temp. | 15min. | Salt Water | | | | | |
| | | | Pre-treatment: Capacitor shall be stored at 85 ±2°C for 1h, then placed at room conditions for 24 ± 2h. | | | | | | | | |
| Post-treatment: Capacitor shall be stored for 24 ± 2h at room conditions. | | | | | | | | | | | |

"Room Condition" Temperature 15 to 35°C, Relative humidity; 45 to 75%, Atmospheric pressure: 6 to 106KPa.

**Y2 AC Ceramic Capacitor
250VAC**

Part No.: **I22003**

| | | | | | | | | | |
|-------|--------|------|--------|--------|--------|-----------|-----------|------------|------------|
| DRW: | Jason | CHKD | Wilson | MATL: | Wilson | TOLERANCE | Mason | DATE | 01.11.2010 |
| APPD: | Schumi | | | FINISH | Jamy | | Sheet No. | 11 from 13 | Customer: |

www.edcon-components.com

email: info@edcon-components.com

EDCON-COMPONENTS



Ordering Informations

| Serie | Range | Temperature Character. | Voltage | Tolerance Code | Lead Style Code | Lead Length Code | Lead Space Code | ROHS | Packing Code | |
|-------|-------|------------------------|---------|----------------|-----------------|------------------|-----------------|------|--------------|--|
|-------|-------|------------------------|---------|----------------|-----------------|------------------|-----------------|------|--------------|--|

| | | | | | | | | | | |
|---------------|------------|----------|------------|----------|----------|-----------|----------|----------|-----------|--|
| I22003 | 103 | E | 251 | M | A | 20 | D | R | BU | |
|---------------|------------|----------|------------|----------|----------|-----------|----------|----------|-----------|--|

| | | | | | | | | |
|------------------------|---------------|-----------------------|---------------|-------------------|-----------------------|------------------|----------------------------|---------------------------|
| 103= 10000pf | | 251= 250VAC | M= 20% | A= Style A | 20= 20mm | A= 2,50mm | R= ROHS Conform | BU= Bulk Ware |
| | E= Y5U | | | B= Style B | 05= 5mm / ±1mm | B= 5,00mm | N= NON ROHS Conform | TA= Tape Ammo Pack |
| | | | | C= Style C | | C= 7,50mm | | TR= Tape Reel |
| | | | | D= Style D | | D= 10,0mm | | |
| | | | | H= Style H | | E= 12,5mm | | |
| | | | | M= Style M | | | | |

**Y2 AC Ceramic Capacitor
250VAC**

Part No.: **I22003**

| | | | | | | | | | |
|-------|--------|------|--------|--------|--------|-----------|-----------|------|------------|
| DRW: | Jason | CHKD | Wilson | MATL: | Wilson | TOLERANCE | Mason | DATE | 01.11.2010 |
| APPD: | Schumi | | | FINISH | Jamy | | Sheet No. | | 12 from 13 |

Customer:



Soldering Profile Curve

Classification Reflow Profile (JEDEC J-STD-020C)



**Y2 AC Ceramic Capacitor
250VAC**

Part No.: **I22003**

| | | | | | | | | | |
|-------|--------|------|--------|--------|--------|-----------|-----------|------------|------------|
| DRW: | Jason | CHKD | Wilson | MATL: | Wilson | TOLERANCE | Mason | DATE | 01.11.2010 |
| APPD: | Schumi | | | FINISH | Jamy | | Sheet No. | 13 from 13 | Customer: |