

# EDCON-COMPONENTS



## Specifications

Dimensions: 15,70x16,80x2,40mm  
 Weight: Approx 1,15g.  
 Contact Principle: Friction Technology  
 Mounting System: SMT Type ( Post Optional)  
 Function: Push/Push Technology  
 Lifetime: 10000cycles min.

Card Detecting Switch State: Normally Open  
 Contact Resistance: 50mΩ Typical, 100mΩ Max.  
 Insulation Resistance: > 1000MΩ Min / 500VDC  
 Rated Current: 0,5A max.  
 Rated Voltage: 30V AC  
 Withstanding Dielectric Voltage: 500V AC RMS for 1 Minute

## Solderability:

Vapor Phase: 215°C for 30Sec.  
 IR Reflow: 260° for 10Sec.  
 Manual Soldering: 360°C for 3 Sec.

## Material

Insulation Material: Thermoplastic UL94V-0  
 Contact Material: Phosphr Bronze  
 Contact Plating: Gold PD over Nickel

## Characteristics

Operating Temperature: . -40°C ~ +85°C  
 Operating Humidity: 10% ~ 95%  
 Storage Temperature: . -40°C ~ +85°C  
 Storage Humidity: 10% ~ 95%  
 Damp Heat: 40°C, 90% RG, 500HR  
 Salt-Mist: 35°C, 5% NaCL, 48H

## SIM CARD Connector

Part No.: **T60018**

DRW:	Jason	CHKD	Wilson	MATL:	Wilson	TOLERANCE	Mason	DATE	10.04.2009	Customer:
APPD:	Schumi			FINISH	Jamy		Sheet No.	1 from 4		

# EDCON-COMPONENTS



## Technical Drawing

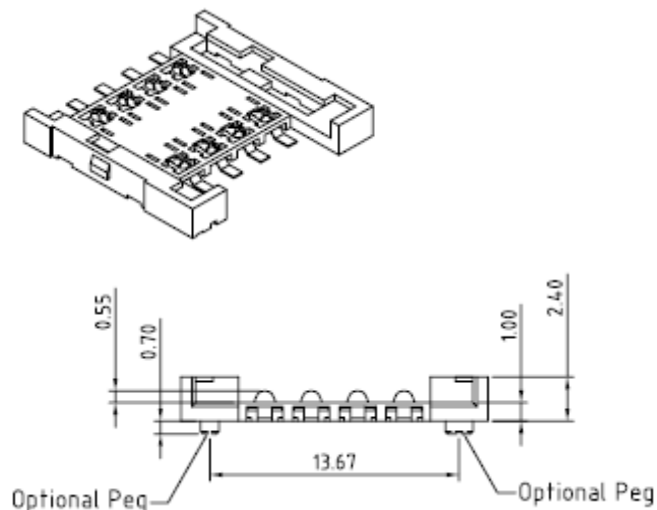

P.C.B. Layout 6Pin

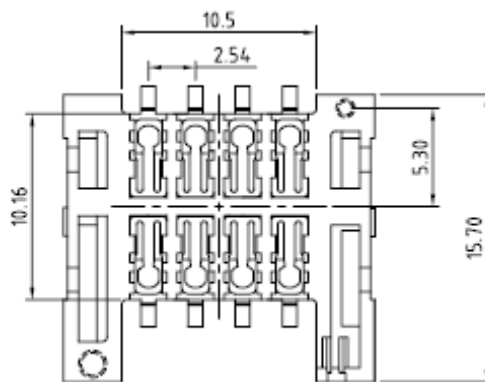

P.C.B. Layout 8Pin

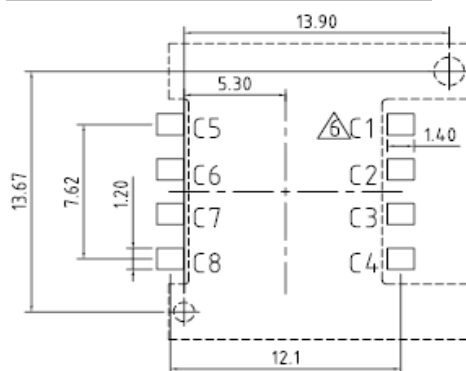
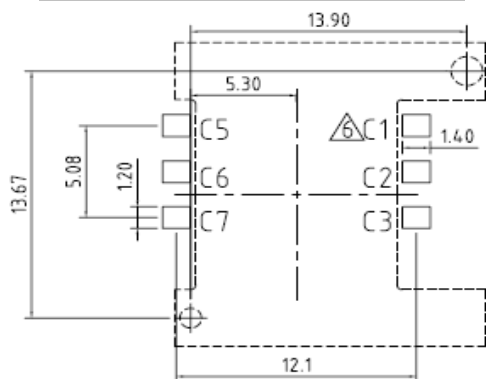
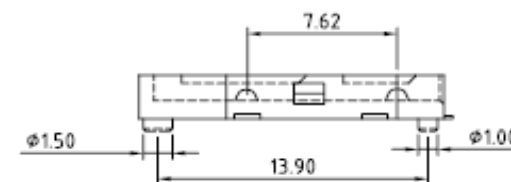
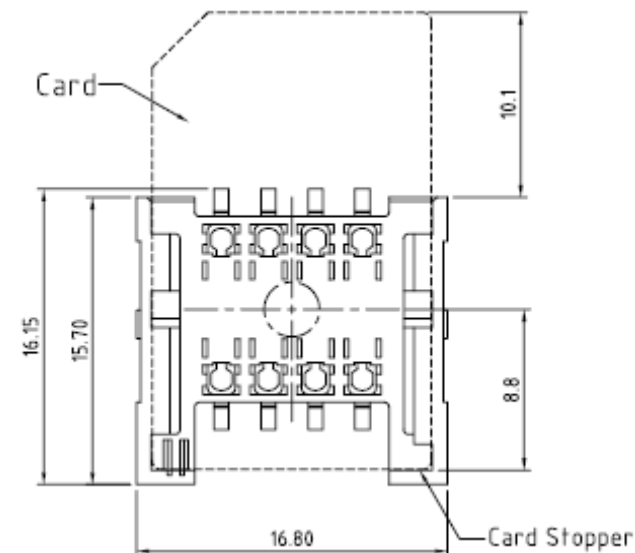

### SIM CARD Connector

Part No.: **T60018**

Customer:

DRW:	Jason	CHKD	Wilson	MATL:	Wilson	TOLERANCE	Mason	DATE	10.04.2009
APPD:	Schumi			FINISH	Jamy		Sheet No.	2 from 4	

# EDCON-COMPONENTS



## Ordering Informations

Serie	Number of Contacts	Switch	Location Peg	Packing						
<b>T60018</b>	<b>6</b>	<b>Y</b>	<b>A</b>	<b>TU</b>						

<b>6=</b> 6 contacts	<b>Y=</b> with Switch	<b>A=</b> with Peg (Standard)	<b>TU=</b> Tube Packing
<b>8=</b> 8 contacts	<b>N=</b> without Switch	<b>B=</b> w/o Peg (Non-Standard)	<b>TR</b> Tape Reel

<b>SIM CARD Connector</b>
Part No.: <b>T60018</b>
Customer:

DRW:	Jason	CHKD	Wilson	MATL:	Wilson	TOLERANCE	Mason	DATE	10.04.2009
APPD:	Schumi			FINISH	Jamy			Sheet No.	3 from 4



Soldering Profile Curve

Classification Reflow Profile (JEDEC J-STD-020C)

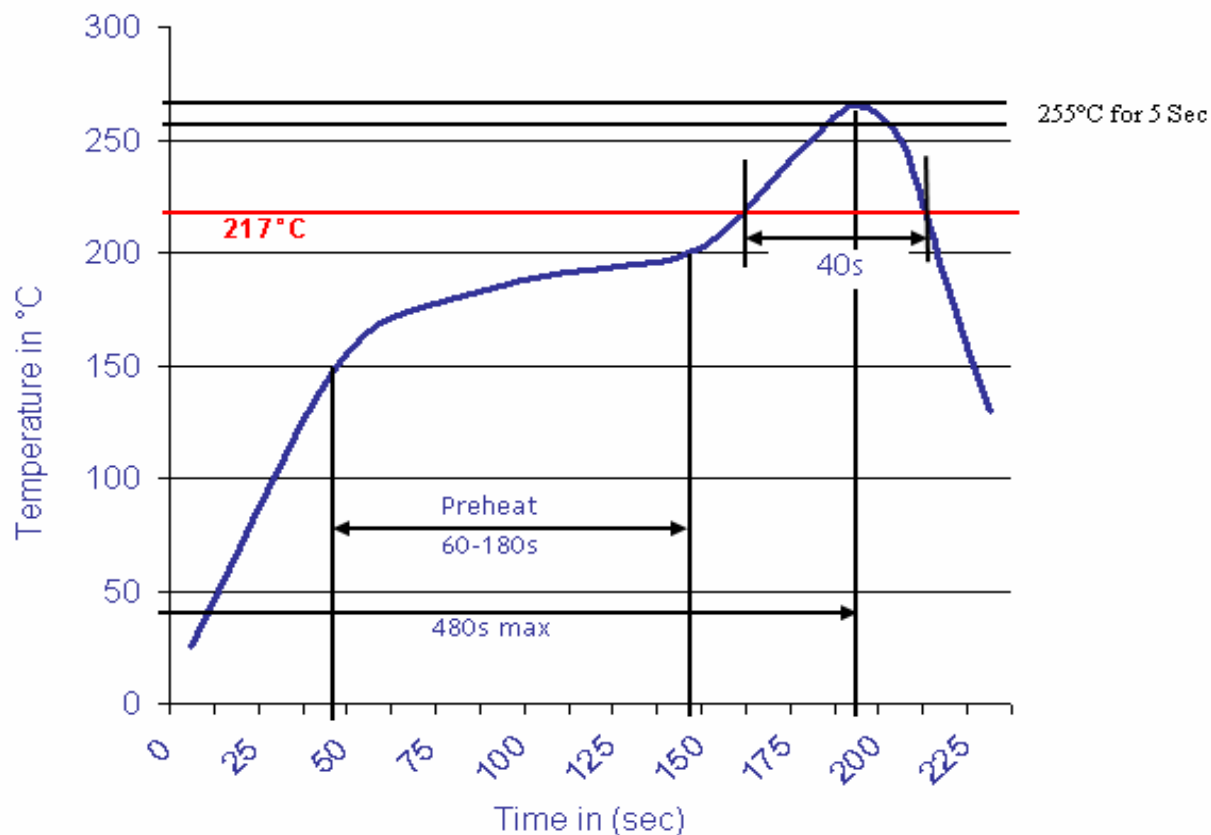

**SIM CARD Connector**

Part No.: **T60018**

Customer:

DRW:	Jason	CHKD	Wilson	MATL:	Wilson	TOLERANCE	Mason	DATE	10.04.2009
APPD:	Schumi			FINISH	Jamy		Sheet No.	4 from 4	