

EDCON-COMPONENTS



Specifications

Features

Plastic package has Underwriters Laboratory Flammability Classification 94V-0
 This Serie is UL listed under Recognized Component Index file number E252843
 High surge current capability

Mechanical Data

Case: Molded plastic body over passivated junctions
 Terminals: plated leads solderable per MIL-STD-750, Method 2026
 Polarity: Polarity symbols marked on body
 Weight: 1,1gr.

Maximum Ratings & Electrical Characteristics Ratings at 25°C ambient temperature

	Sym bols	W005G	W01G	W02G	W04G	W06G	W08G	W10G	Unit
Maximum reecurrent peak reverse Voltage	VRRM	50	100	200	400	600	800	1000	Volt
Maximum rms Input voltage	VRMS	35	70	140	280	420	560	700	Volt
Maximum dc blocking Voltage	VDC	50	100	200	400	600	800	1000	Volt
Maximum average forward output rectified TA=100°C	I(AV)	1,5							Amps
Peak forward surge current 8,3ms single half sine-wave	IFSM	50							Amps
Maximum forward voltage	VF	1,1							Volt
Maximum revese voltage TA=25°C	IR	10							µA
Maximum revese voltage TA=125°C	IR	500							µA
Operating and storage temperature range	TJ TSTG	-55°C to + 150°C							°C
Type junction capacitance VR=4,0V f=1,0Mhz	CJ	14							pF

Technical Drawing (Unit: inch(mm))

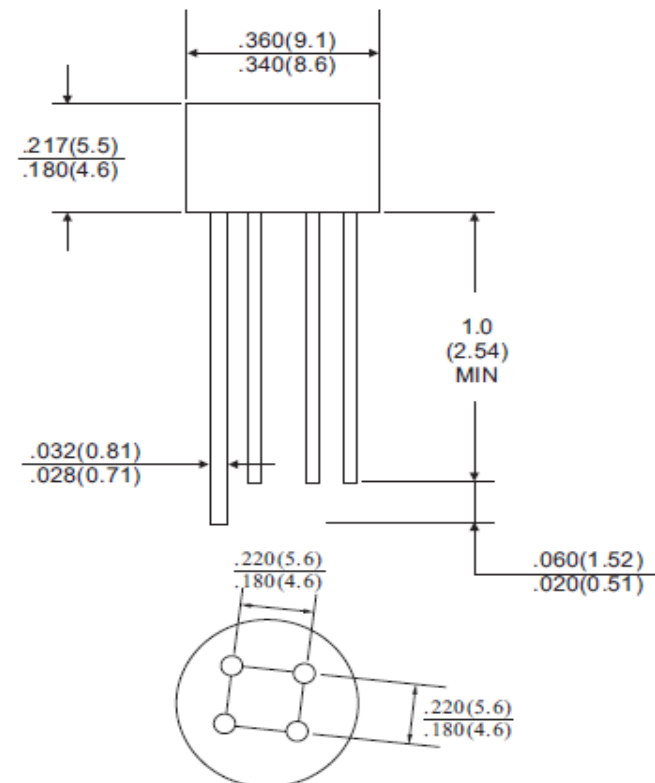

ROUND Bridge Rectifier 1,5A

EDCON-Ser. **E20003**

International Serie: **WxxG**

DRW:	Jason	CHKD	Wilson	MATL:	Wilson	TOLERANCE	Mason	DATE	10.05.2010
APPD:	Schumi			FINISH	Jamy		Sheet No.		1 from 5



Rating & Characteristics Curves (TA=25°C unless otherwise noted)

Derating Curve for Output Rectified Current

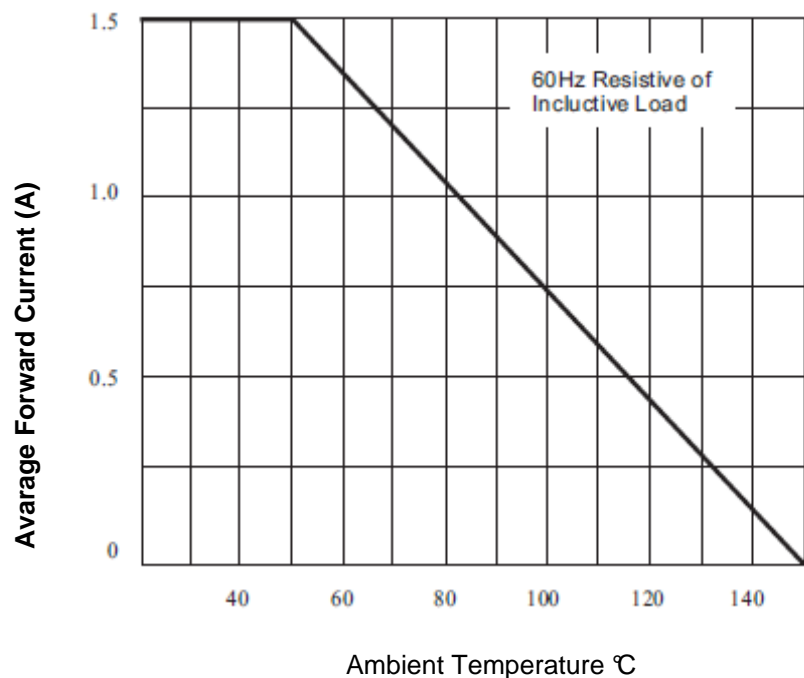

Maximum NON Repetitive Forward Surge Current

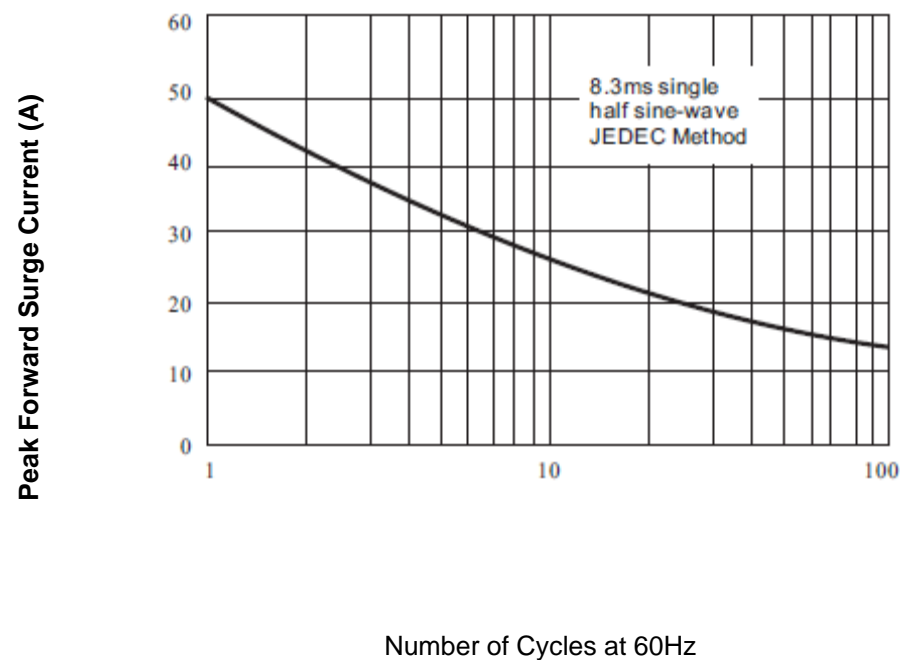

ROUND Bridge Rectifier 1,5A

EDCON-Ser. **E20003**

International Serie: **WxxG**

DRW:	Jason	CHKD	Wilson	MATL:	Wilson	TOLERANCE	Mason	DATE	10.05.2010
APPD:	Schumi			FINISH	Jamy		Sheet No.	2 from 5	



Rating & Characteristics Curves (TA=25°C unless otherwise noted)

Typical Forward Characteristics

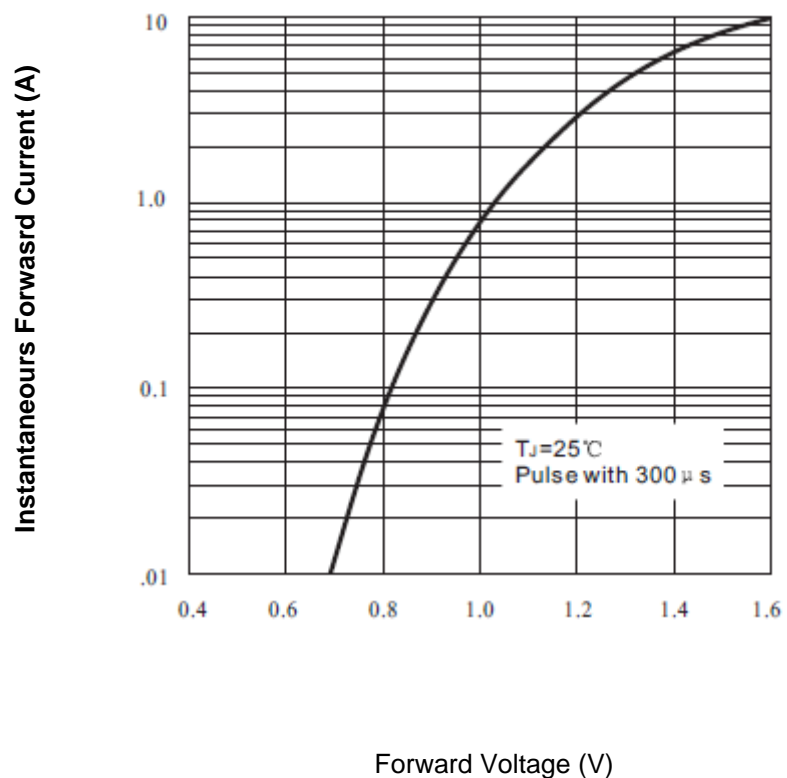

Typical Reverse Characteristics

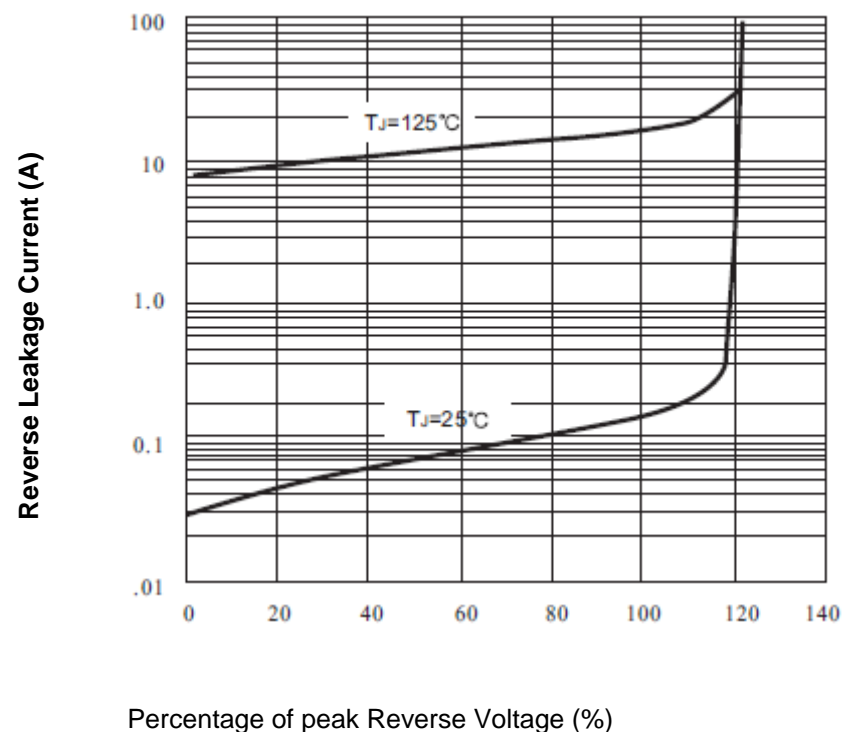

ROUND Bridge Rectifier 1,5A	
EDCON-Ser.	E20003
International Serie:	WxxG

DRW:	Jason	CHKD	Wilson	MATL:	Wilson	TOLERANCE	Mason	DATE	10.05.2010
APPD:	Schumi			FINISH	Jamy		Sheet No.		3 from 5

EDCON-COMPONENTS



Rating & Characteristics Curves (TA=25°C unless otherwise noted)

Forward Current Derating Curve

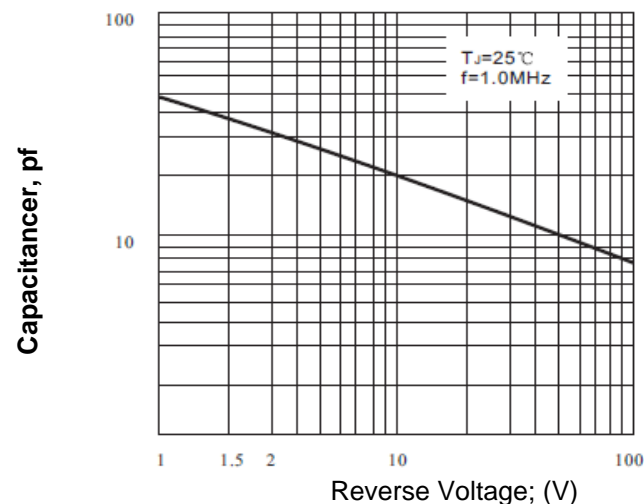

Ordering Informations

EDCON Serie	International Type	NO function	ROHS	Package					
-------------	--------------------	-------------	------	---------	--	--	--	--	--

E20003	WxxG	xx	R	BX					
---------------	-------------	-----------	----------	-----------	--	--	--	--	--

Look Voltage Code Table		R= ROHS Conform	BX= Box
		N= NON ROHS Conform	

ROUND Bridge Rectifier 1,5A	
EDCON-Ser.	E20003
International Serie:	WxxG

DRW:	Jason	CHKD	Wilson	MATL:	Wilson	TOLERANCE	Mason	DATE	10.05.2010
APPD:	Schumi			FINISH	Jamy		Sheet No.		4 from 5



Soldering Profile Curve

Classification Reflow Profile (JEDEC J-STD-020C)



ROUND Bridge Rectifier 1,5A	
EDCON-Ser.	E20003
International Serie:	WxxG

DRW:	Jason	CHKD	Wilson	MATL:	Wilson	TOLERANCE	Mason	DATE	10.05.2010
APPD:	Schumi			FINISH	Jamy		Sheet No.	5 from 5	