



## Technical Specification

### Features

Wire Wound Construction  
 High Saturation Material  
 Poleolefin Shrink Tubing  
 Low DC Resistance  
 High Reliability

### Applications

Switching Regulators  
 RFI Suppression Filters  
 SCR and TRIAC Controls Systems  
 Automotive Systems

### Electrical Schematic



### Dimensions

C (mm)	D (mm)
29,21	1,01

### Dimensions

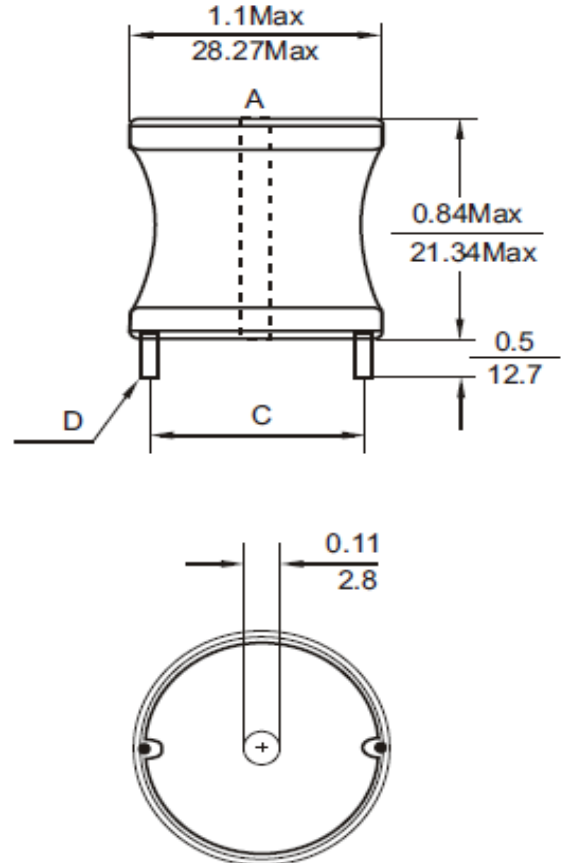

## Electrical Characteristics

### Technical Information

Testing LCR Bridge, measured @ 1KHz 0,1V HP4284A  
 Equivalent acceptacle  
 RDC. QuadTech 1880 Milliohmmeter  
 Rated Current: L value drop 10% typ. At Idc against  
 the initial value Temperature rise 40 Max. Referrence  
 ambient temperature  
 Solderability: 75% of the lead wire shall be covered  
 Solder Methods: Wave, Reflow  
 Operating Temperature: -40°C ~ +85°C  
 Storage Temperature: -40°C ~ +125°C  
 Marking: Inductance and tolerance  
 Moisture resistance: L/L 10% Q/Q 25%  
 Note: All specifications subject to change without  
 notice.

Inductance	Inductance Code	IDC	DCR max.
1000μH	102	5,5A	0,216Ω

### THT Radial Extremely High Current

Part No.: **S10R40**

Customer:

DRW:	Jason	CHKD	Jules	MATL:	Wu	DATE	16.05.2009
APPD:	Join			FINISH	Shieh	Sheet	1 from 2

Copyright by EDCON-COMPONENTS H.Schmitt 20.6.2008



**Soldering Profile**

**Classification Reflow Profile (JEDEC J-STD-020C)**



**Ordering Information**

Serie	Inductance	Tolerance	No Function	ROHS	Packing
<b>S10R40</b>	<b>102</b>	<b>K</b>	<b>0</b>	<b>R</b>	<b>BU10</b>

<b>102=</b> 1000µH	<b>K=</b> Tol. 10%	<b>0=</b> No function	<b>R=</b> ROHS conform	<b>BU=</b> Bulk Ware
	<b>J=</b> Tol. 5%		<b>N=</b> NON ROHS conform	<b>TY=</b> Tray Package

<b>THT Radial Extremely High Current</b>	
Part No.:	<b>S10R40</b>
Customer:	

DRW:	Jason	CHKD	Jules	MATL:	Wu	DATE	16.05.2009
APPD:	Join			FINISH	Shieh	Sheet	2 from 2

