



Technical Specification

Features

- Wire Wound Construction
- Excellent heat resistance
- Excellent environmental characteristics
- High reliability

Applications

- Power Supplies
- SCR and TRIAC Controls
- RFI Suppression
- Filters
- Switching Regulators

Technical Dimensions

| A (mm) | B (mm) | C (mm) | D (mm) |
|--------|------------|------------|--------|
| 14,4 | 5,0 +/-1,0 | 5,0 +/-0,3 | 10,5 |
| E (mm) | | | |
| 0,7 | | | |

Dimensions

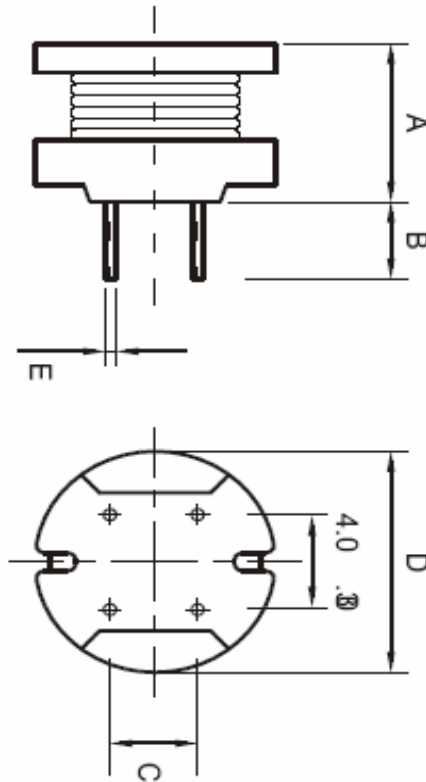

Electrical Characteristics

Technical Information

Testing LCR Bridge, measured @ 1KHz 0,1V HP4284A
 Equivalent acceptacle
 RDC. QuadTech 1880 Milliohmmer
 IDC: Max. Lowers inductance by 10%
 Operating Temperature: -55°C ~ +125°C
 Storage Temperature: -55°C ~ +125°C
 Solder Methods: Vapor Phase, Infrared Reflow
 Marking: Inductance and tolerance
 Note: All specifications subject to change without notice.

| Inductance | Inductance Code | IDC | DCR max. |
|------------|-----------------|--------|----------|
| 470µH | 471 | 0,840A | 0,650Ω |

THT Radial Power Choke

Part No.: **S10R22**

Customer:

| | | | | | | | |
|-------|-------|------|-------|--------|-------|-------|------------|
| DRW: | Jason | CHKD | Jules | MATL: | Wu | DATE | 02.05.2009 |
| APPD: | Join | | | FINISH | Shieh | Sheet | 1 from 2 |



Soldering Profile

Classification Reflow Profile (JEDEC J-STD-020C)



Ordering Information

| Serie | Inductance | Tolerance | Lead Length | ROHS | Packing |
|-------|------------|-----------|-------------|------|---------|
|-------|------------|-----------|-------------|------|---------|

| | | | | | |
|---------------|------------|----------|-----------|----------|-------------|
| S10R22 | 471 | M | 50 | R | BU10 |
|---------------|------------|----------|-----------|----------|-------------|

| | | | | |
|------------|-------------|----------|--------------------|------------------|
| 471= 470µH | M= Tol. 20% | 50= 5mm | R= ROHS conform | BU= Bulk Ware |
| | K= Tol. 10% | 15= 15mm | N=NON ROHS conform | TY= Tray Package |

| | |
|-------------------------------|---------------|
| THT Radial Power Choke | |
| Part No.: | S10R22 |
| Customer: | |

| | | | | | | | |
|-------|-------|------|-------|--------|-------|-------|------------|
| DRW: | Jason | CHKD | Jules | MATL: | Wu | DATE | 02.05.2009 |
| APPD: | Join | | | FINISH | Shieh | Sheet | 2 from 2 |

