

# EDCON-COMPONENTS



## Technical Specifications:

Temperature Range:	DC 24V 5,0A
Rated Load:	3~20n
Contact Resistance:	0,5KG ~ 3,5KG
Insulation Resistance:	
Withstanding Voltage:	500 VOLTS
Actuating Force:	
Lifetime:	5000 cycles
TEMPERATURE:	FROM -30°C TO +70°C
RELATIVE HUMIDITY:	FROM 40% TO 85%
HUMIDITY TEST:	HUMIDITY 90% TO 95% TEMPERATURE 40°C +/- 2°C F. 96 HRS
HEAT TEST:	TEMPERATURE 70°C +/- 2°C V (HUMIDITY BELOW 50% F. 96HRS
COLD TEST:	. +/-2°C FOR 96 HOURS
SOLDERABILITY TEST:	THE TERMINATION IS AT LEAST 96% COVERD BY A CONTINIOUS NEW SOLDER COATING
TEST CONDITIONS:	DIP SOLDER FOR 5 SEC AT 245°C +/- 5°C TERMINATION SHAL BE IMMERSD IN FLUX BEFORE TEST
REFLOW SOLDERING:	LEAD FREE PROCESS
MATERIAL:	STAINLESS 0,1T
F= GROUNDING SPRING	BRASS STRIP 0,3T NI 60μ
E= SHIELDING:	BRASS BAR NI 60μ
D= PIN	BRASS STRIP 0,3T AG 20μ OVER NI 20μ
C=TERMINAL	COPPER ALLOY 0,3T AG20μ OVER NI 20μ
B= TIP SPRING	HIGH TEMPERATURE THERMOPLASTIC UL 94V-0 BLACK
A= BODY	

### SMT DC-POWER JACK

Part No.: **T19A012**

Customer:

DRW:	Jason	CHKD	Wilson	MATL:	Wilson	DATE	06.11.2018
APPD:	Schumi			FINISH	Jamy	Sheet	1 from 3



**Technical Drawing:**

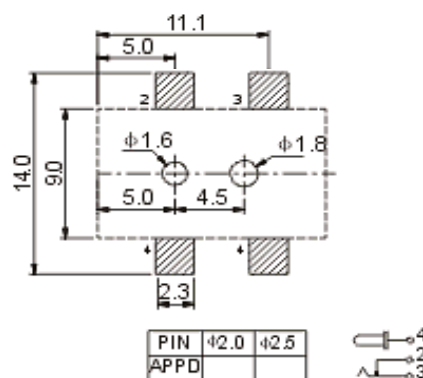
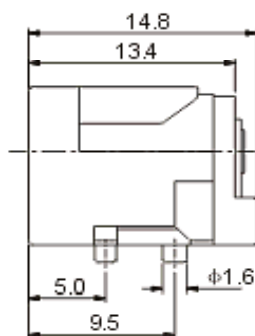
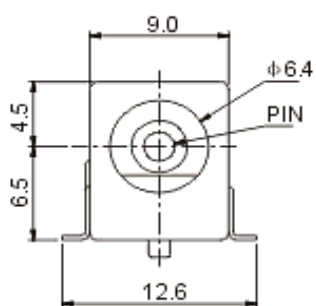

**SMT DC-Power Jack**

Part No.: **T19A012**

Customer:

DRW:	Jason	CHKD	Wilson	MATL:	Wilson	DATE	06.11.2018
APPD:	Schumi			FINISH	Jamy	Sheet	2 from 3



**Solder Profile**

**Lead Solder**

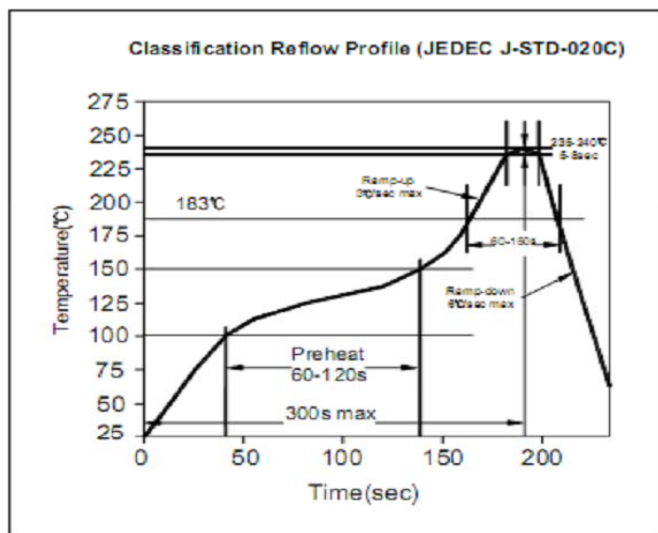

**Lead Free Solder**

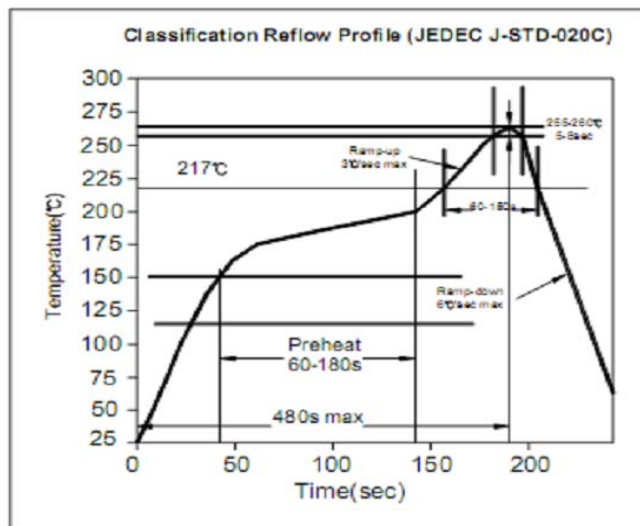

**Ordering Informations:**

Item-No.	Pin Diameter	ROHS	Packing		
<b>T19A012</b>	<b>A</b>	<b>R</b>	<b>TR</b>		

<b>A= 2,0mm</b>	<b>R= ROHS</b>	<b>BU= Bulk (Standard)</b>
<b>B= 2,5mm</b>	<b>N= Non ROHS</b>	
		<b>TR= Tape/Reel</b>
		<b>TY= Tray Packing</b>

<b>SMT DC-Power Jack</b>	
Part No.:	<b>T19A012</b>
Customer:	

DRW:	Jason	CHKD	Wilson	MATL:	Wilson	DATE	06.11.2018
APPD:	Schumi			FINISH	Jamy	Sheet	3 from 3