



General

SMA connectors are subminiature units designed to provide high electrical performance for microwave applications up to 18 GHz.

Constructed with brass or high quality stainless steel, SMA connectors ensure excellent durability and mechanical strength.

INTERFACE MATING DIMENSIONS



Plug		
Letter	mm	
	min.	max.
A	6.35	6.73
B	4.53	4.59
C	2.54	3.43
D	0.00	0.25
E	1.91	2.54
F	0.00	0.25
G	0.00	0.94
H	0.00	0.38
J	1.24	1.30

Jack		
Letter	mm	
	min.	max.
A	5.28	5.49
B	4.60	4.67
C	1.88	1.98
D	0.00	0.25
E	0.38	1.14
F	2.92	---
G	0.00	0.25
H	4.32	---
J	1.24	1.30
K	5.54	---

Note: I.D. to meet VSWR and Contact Resistance when mated with 0.38/0.42 mm dia. pin.

Cable Crimp SMA	
Part No.:	T55J1041
Customer:	

DRW:	Dong	CHKD	Chang	MATL:	Chui	DATE	20.09.2010
APPD:	Ping			FINISH	Hui	Sheet	1 from 3



Specifications

<i>Electrical</i>		
Impedance		50 Ω
Frequency Range		0 - 12.4 GHz on Flexi. Cable 0 - 18 GHz on Semi-rigid cable
Working Voltage		RG-178: 170 VRMS max. RG-316, 085": 250 VRMS max. RG-142, 141": 335 VRMS max.
Dielectric Withstanding Voltage		RG-178: 500 VRMS max. RG-316, 085": 750 VRMS max. RG-142, 141": 1000 VRMS max.
VSWR	Straight Right Angle	1.3 max. 1.5 max.
Contact Resistance	Center Contact Outer Contact	6 mΩ max. 2 mΩ max.
Insulator Resistance		5000 MΩ min.

<i>Material</i>		
Parts Name	Material	Finish
Body, Metal Parts	Brass per QQ-B-626	Gold 3 micro-inches
Center Contacts	Male: Brass per QQ-B-626 Female: Beryllium copper per QQ-C-530	Gold 30 micro-inches Gold 30 micro-inches
Insulators	Teflon	None
Crimp Ferrules	Annealed Brass	Gold 3 micro-inches
Clamp Gaskets	Silicone rubber	None

<i>Mechanical & Environmental</i>	
Engagement Force	2 in-lbs. max.
Disengagement Force	2 in-lbs. max.
Coupling Nut Retention	60 lbs. min.
Coupling Proof Torque	15 in-lbs min.
Contact Retention	6 lbs min.
Durability (Mating)	500 cycles
Temperature Range	-65°C ~ 155°C
Vibration	MIL-STD-202 Method 204 Test Cond. B
Salt Spray	MIL-STD-202 Method 101 Test Cond. B
Thermal Shock	MIL-STD-202 Method 107 Test Cond. B

Cable Crimp SMA	
Part No.:	T55J1041
Customer:	

DRW:	Dong	CHKD	Chang		MATL:	Chui	DATE	20.09.2010
APPD:	Ping				FINISH	Hui	Sheet	2 from 3



Technical Drawing

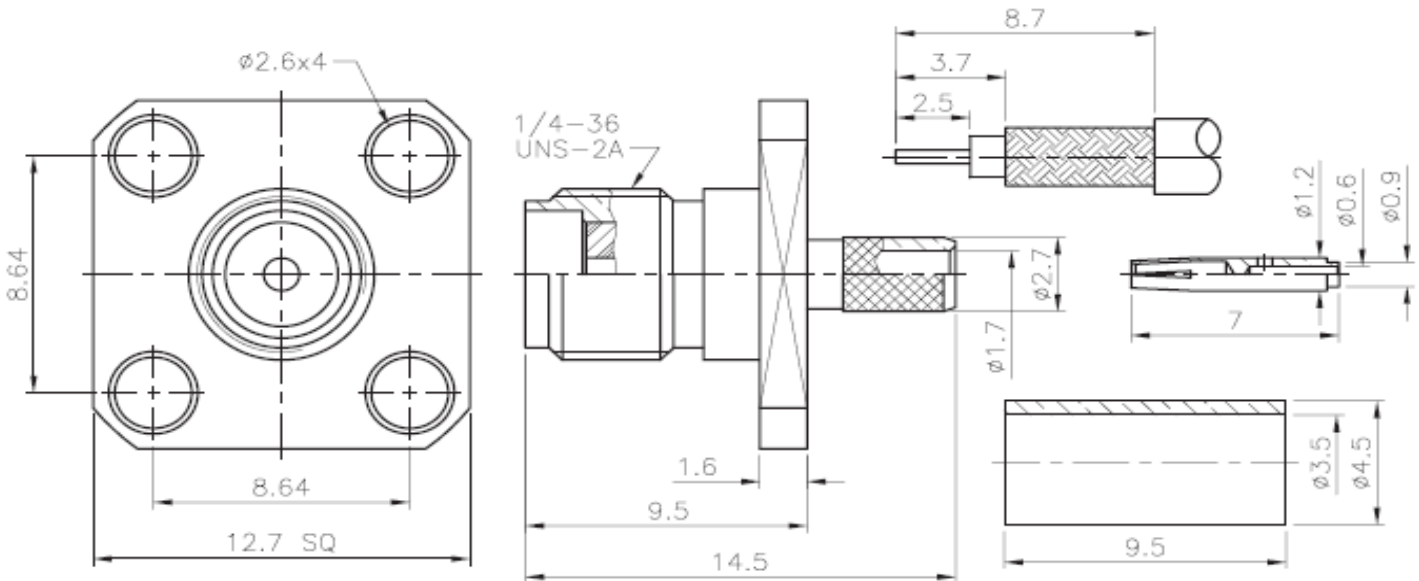

Ordering Information

Serie	-	Cable Group	Impedance	No Function	RoHS	Packing
T55J1041	-	B1	50	XX	R	BU
EDCON-Serie	-	B1 = RG-316U/D	50 = 50 Ω	XX	N = no RoHS conform R = RoHS conform	BU = Bulk Ware IV = Individual Packing

**Cable Crimp
 SMA**

Part No.: **T55J1041**

Customer:

DRW:	Dong	CHKD	Chang	MATL:	Chui	DATE	20.09.2010
APPD:	Ping			FINISH	Hui	Sheet	3 from 3