



General

SSMB Series in a microminiature connectors with snap-on mating (smaller version of SMB series), designed to MIL-PRF-39012 requirements. The design permits rapid connection and disconnection in small spaces, even in inaccessible locations.

SSMB series provides excellent electrical performance in a microminiature footprint. While the snap-on mating interface allows quick installation and dense packaging, the excellent electrical performance of the SSMB series allows it to be used in many applications as an alternative to larger connectors like SMAs.

INTERFACE MATING DIMENSIONS

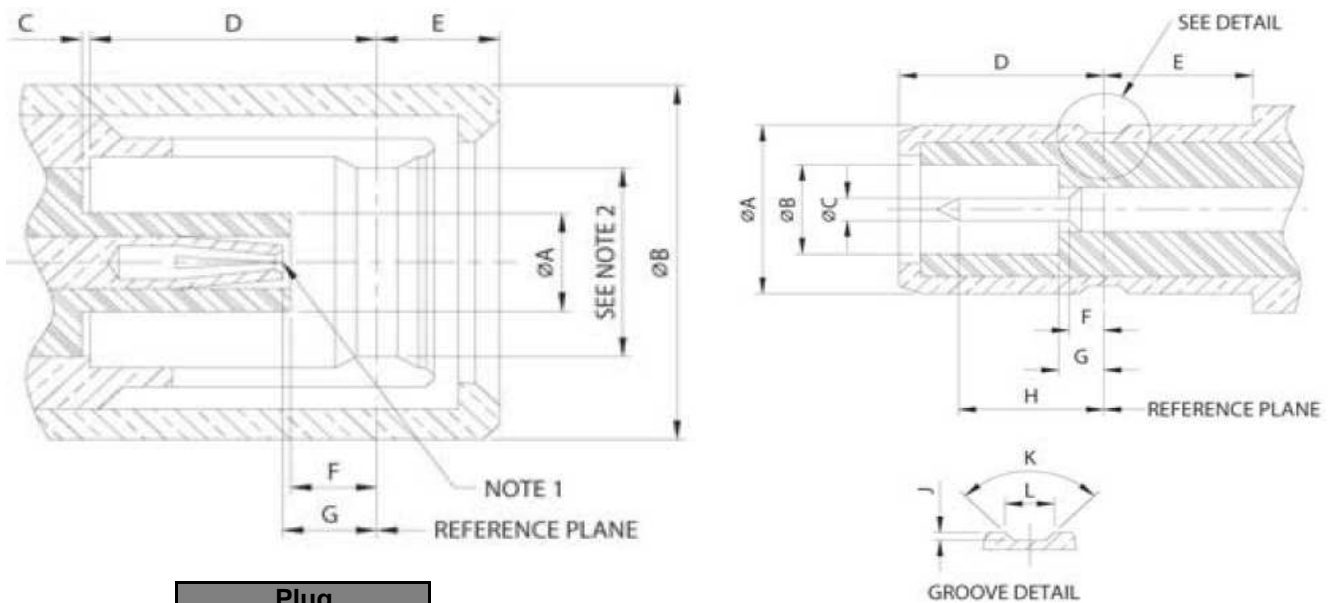

Plug		
Letter	mm	
	min.	max.
A	---	1.34
B	---	4.82
C	0.00	---
D	3.10	---
E	---	1.78
F	0.84	---
G	0.84	---

Jack		
Letter	mm	
	min.	max.
A	---	2.67
B	1.37	---
C	0.35	0.38
D	---	3.10
E	1.91	---
F	---	0.84
G	---	0.84
H	1.91	---
J	0.05	0.15
K	89	91
L	0.71	0.74

Note: I.D. to meet VSWR and Contact Resistance when mated with 0.35/0.38 mm dia. pin.

PCB Mount SSMB	
Part No.:	T55E1008
Customer:	

DRW:	Dong	CHKD	Chang	MATL:	Chui	DATE	04.12.2009
APPD:	Ping			FINISH	Hui	Sheet	1 from 3



Specifications

<i>Electrical</i>		
Impedance	50 Ω	
Frequency Range	0 - 4 GHz	
Working Voltage	250 VRMS max.	
Dielectric Withstanding Voltage	750 VRMS max.	
VSWR	Straight	1.3+0.02 F (GHz) max.
	Right Angle	1.3+0.03 F (GHz) max.
Contact Resistance	Center Contact	5 mΩ max.
	Outer Contact	2.5 mΩ max.
Insulator Resistance	1000 MΩ min.	

<i>Material</i>		
Parts Name	Material	Finish
Body, Metal Parts	Brass per QQ-B-626	Gold 3 micro-inches
Center Contacts	Male: Brass per QQ-B-626	Gold 30 micro-inches
	Female: Beryllium copper per QQ-C-530	Gold 30 micro-inches
Insulators	Teflon	None
Crimp Ferrules	Annealed Brass	Gold 3 micro-inches

<i>Mechanical & Environmental</i>	
Engagement Force	6 lbs. max.
Disengagement Force	6 lbs. max.
Coupling Nut Retention	Not applicable
Coupling Proof Torque	Not applicable
Contact Retention	2 lbs. min.
Durability (Mating)	500 cycles
Temperature Range	-65°C ~ 165°C
Vibration	MIL-STD-202 Method 204 Test Cond. B
Salt Spray	MIL-STD-202 Method 101 Test Cond. B
Thermal Shock	MIL-STD-202 Method 107 Test Cond. B

PCB Mount SSMB	
Part No.:	T55E1008
Customer:	

DRW:	Dong	CHKD	Chang	MATL:	Chui	DATE	04.12.2009
APPD:	Ping			FINISH	Hui	Sheet	2 from 3



Technical Drawing

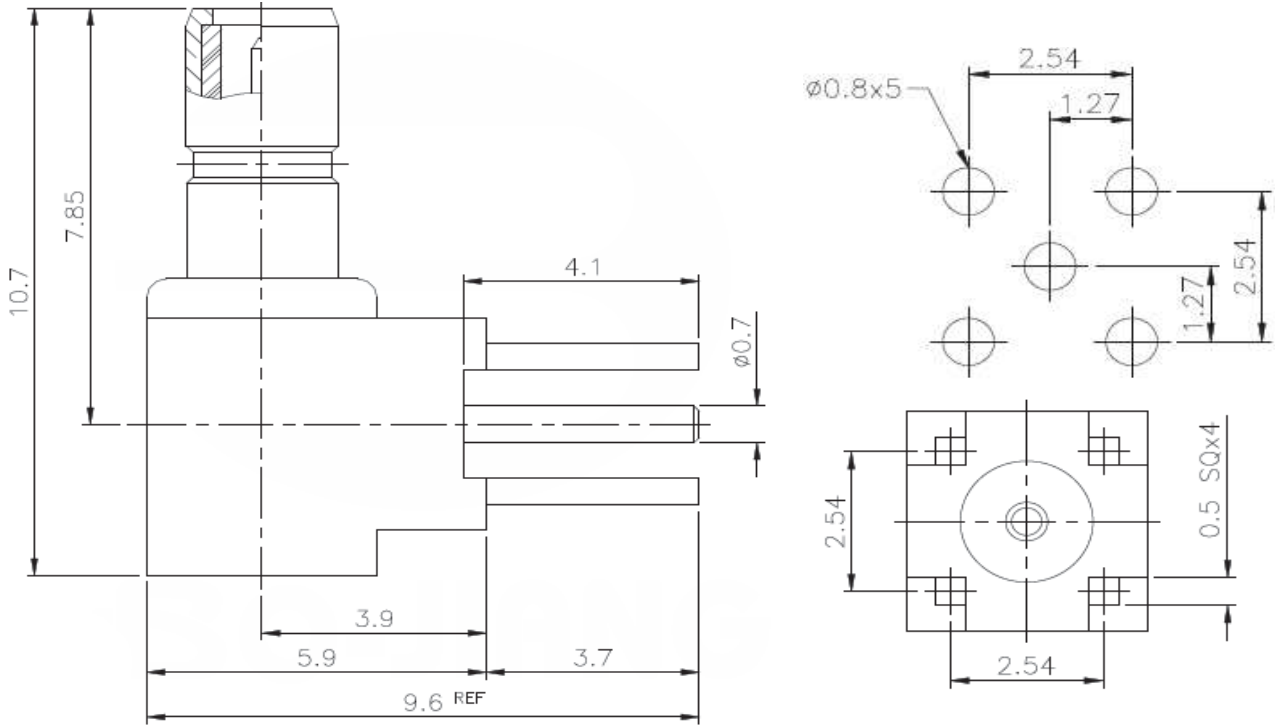

Odering Information

Serie	-	Cable Group	Impedance	No Function	RoHS	Packing
T55E1008	-	G5	50	XX	R	BU
EDCON-Serie	-	G5 = Blunt Post	50 = 50 Ω	XX	N = no RoHS conform R = RoHS conform	BU = Bulk Ware IV = Individual Packing

PCB Mount SSMB	
Part No.:	T55E1008
Customer:	

DRW:	Dong	CHKD	Chang	MATL:	Chui	DATE	04.12.2009
APPD:	Ping			FINISH	Hui	Sheet	3 from 3