



General

Mini UHF series are lightweight, compact coaxial connectors designed for most mobile communications systems and applications where miniaturization, weight and cost elements are essential. The threaded coupling provides excellent RF performance.

Specifications

Electrical		
Impedance		50 Ω
Frequency Range		0 - 2 GHz
Working Voltage		335 VRMS max.
Dielectric Withstanding Voltage		1000 VRMS min.
VSWR	Straight	1.3 max.
	Right Angle	1.5 max.
Contact Resistance	Center Contact	5 mΩ max.
	Outer Contact	3 mΩ max.
Insulator Resistance		5000 MΩ min.

Material		
Parts Name	Material	Finish
Body, Metal Parts	Brass per QQ-B-626	Nickel 70 micro-inches
Center Contacts	Male: Brass per QQ-B-626 Female: Phosphor Bronze per QQ-B-626	Gold 3 micro-inches Gold 3 micro-inches
Insulators	Teflon, Delrin	None
Crimp Ferrules	Annealed Brass	Nickel 70 micro-inches

Mechanical & Environmental	
Engagement Force	2 in-lbs. max.
Disengagement Force	2 in-lbs. max.
Coupling Nut Retention	80 lbs. min.
Coupling Proof Torque	15 in-lbs. min.
Contact Retention	6 lbs. min.
Durability (Mating)	500 cycles
Temperature Range	-65°C ~ 165°C
Vibration	MIL-STD-202 Method 204 Test Cond. B
Salt Spray	MIL-STD-202 Method 101 Test Cond. B

Cable, Crimp Mini UHF	
Part No.:	T55C2001
Customer:	

DRW:	Dong	CHKD	Chang	MATL:	Chui	DATE	03.05.2010
APPD:	Ping			FINISH	Hui	Sheet	1 from 2

Copyright by EDCON-COMPONENTS



Technical Drawing

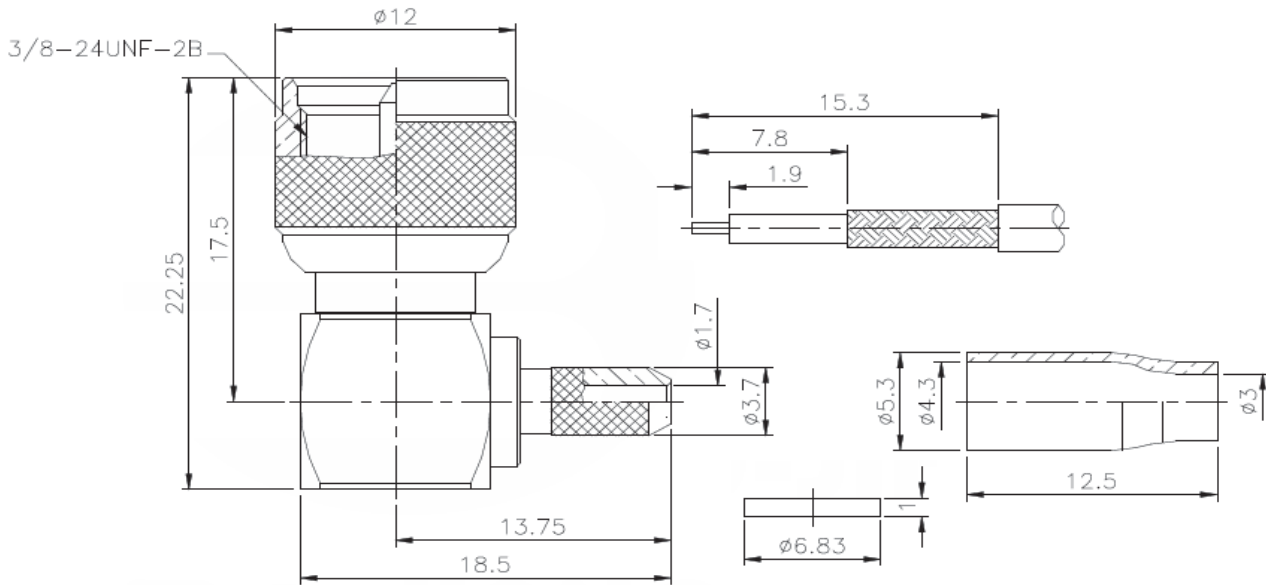

Odering Information

Serie	-	Cable Group	Impedance	No Function	RoHS	Packing
T55C2001	-	A9	50	XX	R	BU
EDCON-Serie	-	A9 = RG-174/U, 188A/U, 316/U, LMR-100	50 = 50 Ω	XX	N = no RoHS conform R = RoHS conform	BU = Bulk Ware IV = Individual Packing

Cable, Crimp Mini UHF	
Part No.:	T55C2001
Customer:	

DRW:	Dong	CHKD	Chang	MATL:	Chui	DATE	03.05.2010
APPD:	Ping			FINISH	Hui	Sheet	2 from 2