

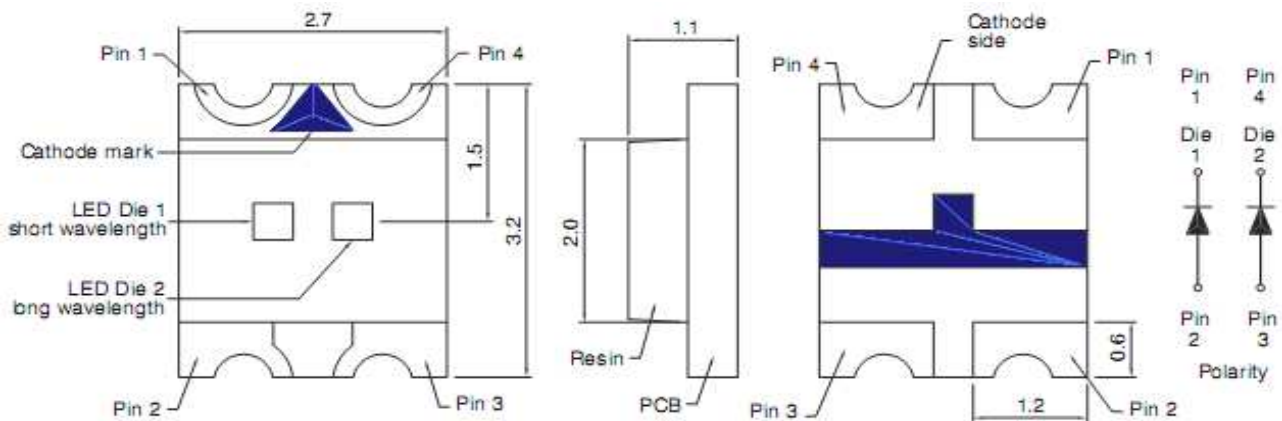

**Applications**

- Interior automotive lighting
- Optical indicators
- Communication Products
- Backlighting
- Toys

**Technical Drawing**



**Recommended Soldering Pattern**

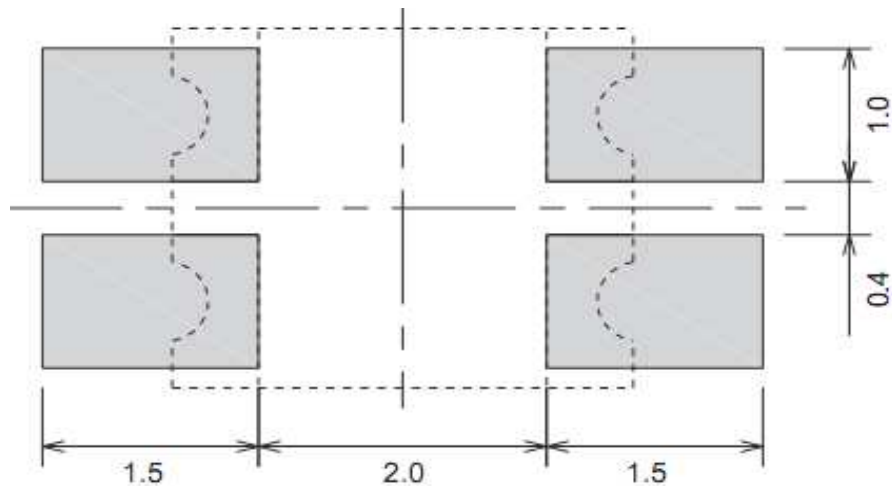

**Notes :**

All dimensions in mm tolerance is  $\pm 0.1\text{mm}$  unless otherwise noted.

|                         |                 |
|-------------------------|-----------------|
| <b>SMT Top View LED</b> |                 |
| <b>Amber</b>            | <b>Blue</b>     |
| Part No.:               | <b>M11C2009</b> |
| Customer:               |                 |

|       |      |      |       |        |      |       |            |
|-------|------|------|-------|--------|------|-------|------------|
| DRW:  | Dong | CHKD | Chang | MATL:  | Chui | DATE  | 04.12.2009 |
| APPD: | Ping |      |       | FINISH | Hui  | Sheet | 1 from 9   |



**Absolute Maximum Ratings**

Ta=25°C

| Item                   | Symbol            | AllnGaP   | InGaN | Unit |
|------------------------|-------------------|-----------|-------|------|
| Power Dissipation      | P <sub>D</sub>    | 72        | 78    | mW   |
| DC Forward Current     | I <sub>F</sub>    | 30        | 20    | mA   |
| Plused Forward Current | I <sub>FP</sub> * | 100       | 80    | mA   |
| Reverse Voltage        | V <sub>R</sub>    | 5         |       | V    |
| Operating Temperature  | T <sub>OP</sub>   | -30 to 80 |       | °C   |
| Storage Temperature    | T <sub>ST</sub>   | -40 to 85 |       | °C   |

\* 0.1 msec pulse, 10% duty cycle

**Electrcal / Optical Characteristics**

I<sub>F</sub>=20mA Ta=25°C

| Ermitting Color<br>Material | Amber          |         | Blue |                |
|-----------------------------|----------------|---------|------|----------------|
|                             |                | AllnGaP |      | InGaN          |
| Forward Voltage             | typ.           | 1.9     | 3.3  | V <sub>F</sub> |
|                             | max.           | 2.4     | 3.9  | V <sub>F</sub> |
| Wavelength<br>typ.          | λ <sub>D</sub> | 605     | 470  | nm             |
|                             | λ <sub>P</sub> | 609     | 468  | nm             |
|                             | Δλ             | 17      | 40   | nm             |
| Color Temperature           | min.           | ---     | ---  | K              |
|                             | max.           | ---     | ---  | K              |
| Luminous Intensity *        | min.           | 40      | 36   | mcd            |
|                             | typ.           | 90      | 56   | mcd            |
| Reverse Current             | max.           | ---     |      | μA             |
| Viewing Angle               | 2Θ1/2          | 140     |      |                |

\* Per NIST standards

|                         |                 |
|-------------------------|-----------------|
| <b>SMT Top View LED</b> |                 |
| <b>Amber</b>            | <b>Blue</b>     |
| Part No.:               | <b>M11C2009</b> |
| Customer:               |                 |

|       |      |      |       |        |      |       |            |
|-------|------|------|-------|--------|------|-------|------------|
| DRW:  | Dong | CHKD | Chang | MATL:  | Chui | DATE  | 04.12.2009 |
| APPD: | Ping |      |       | FINISH | Hui  | Sheet | 2 from 9   |



**Directive Characteristics**

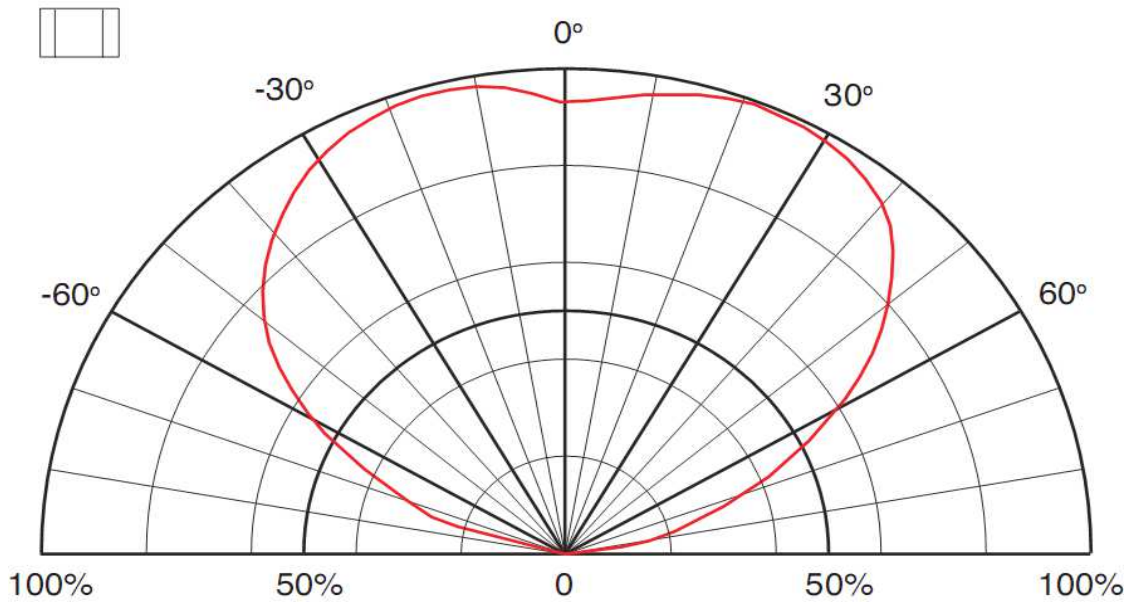
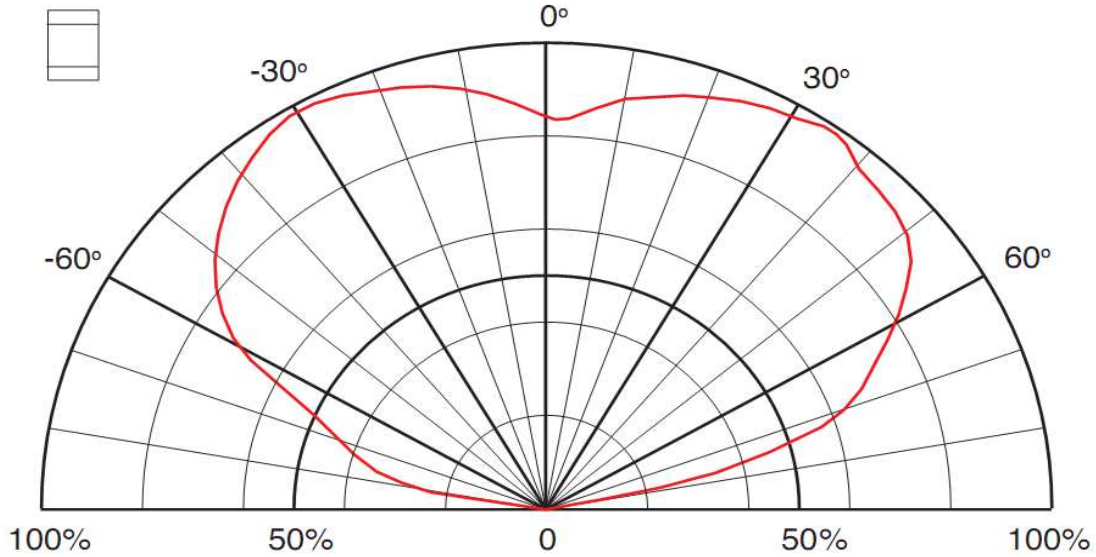

|                         |                 |
|-------------------------|-----------------|
| <b>SMT Top View LED</b> |                 |
| <b>Amber</b>            | <b>Blue</b>     |
| Part No.:               | <b>M11C2009</b> |
| Customer:               |                 |

|       |      |      |       |        |      |       |            |
|-------|------|------|-------|--------|------|-------|------------|
| DRW:  | Dong | CHKD | Chang | MATL:  | Chui | DATE  | 04.12.2009 |
| APPD: | Ping |      |       | FINISH | Hui  | Sheet | 3 from 9   |



**Curvs**

Relative Intensity vs. Forward Current

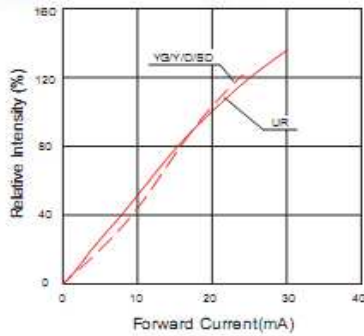

Forward Current vs. Forward Voltage

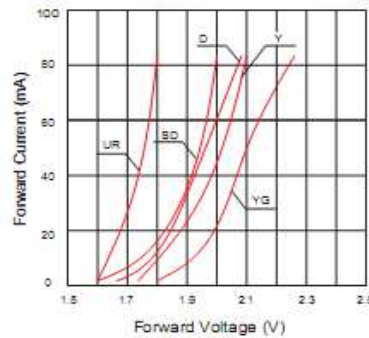

Relative Intensity vs. Forward Current

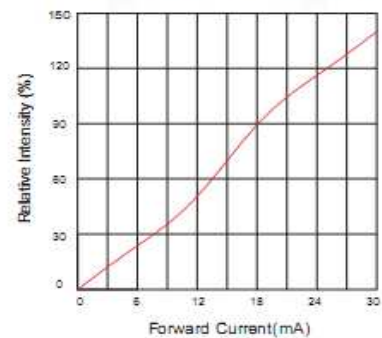

Relative Intensity vs. Forward Current

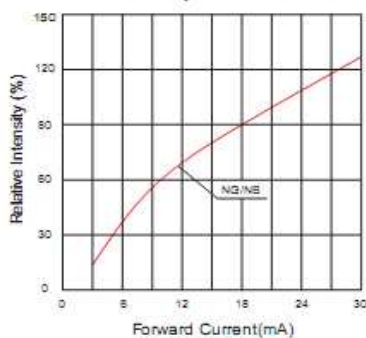

Forward Current vs. Forward Voltage

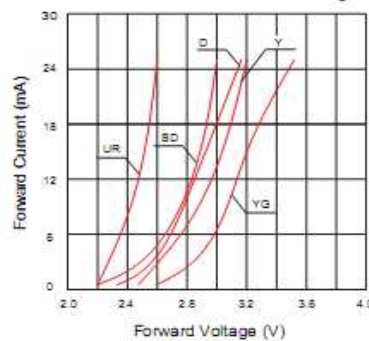

Forward Current vs. Ambient Temperature

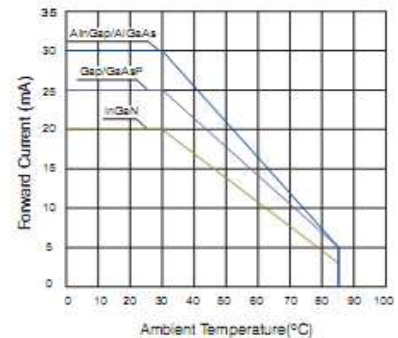

Forward Current vs. Forward Voltage

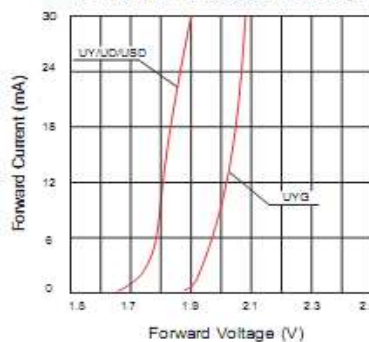

**SMT Top View LED**  
**Amber** **Blue**

Part No.: **M11C2009**

Customer:

|       |      |      |       |        |      |       |            |
|-------|------|------|-------|--------|------|-------|------------|
| DRW:  | Dong | CHKD | Chang | MATL:  | Chui | DATE  | 04.12.2009 |
| APPD: | Ping |      |       | FINISH | Hui  | Sheet | 4 from 9   |



**Solder Condition**

**Lead Free Solder**

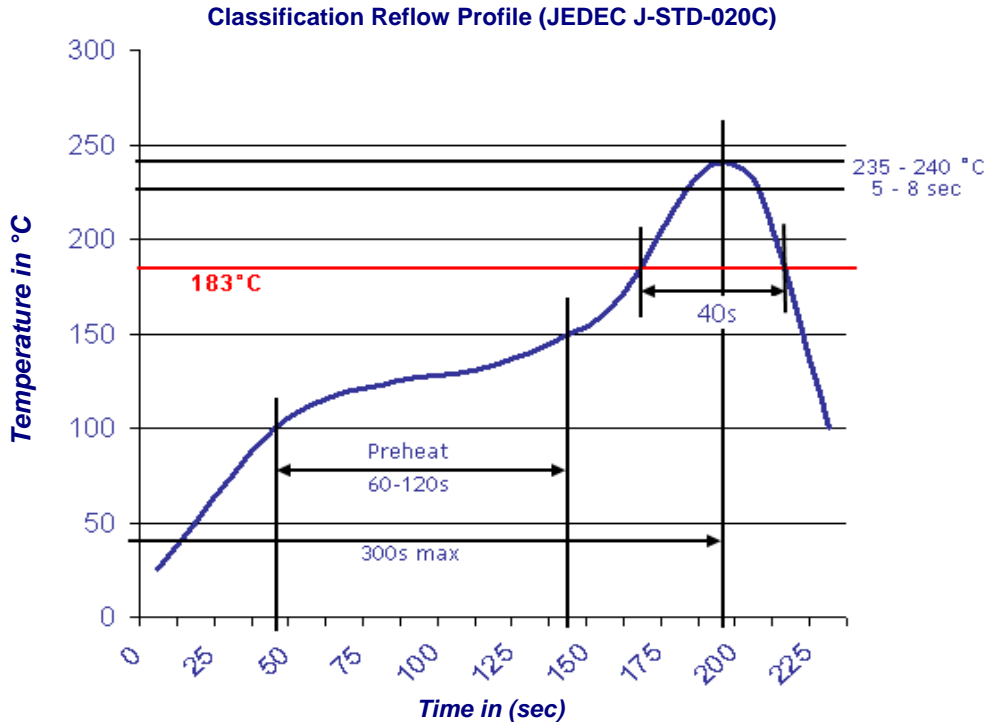

|                         |                 |
|-------------------------|-----------------|
| <b>SMT Top View LED</b> |                 |
| <b>Amber</b>            | <b>Blue</b>     |
| Part No.:               | <b>M11C2009</b> |
| Customer:               |                 |

|       |      |      |       |        |      |       |            |
|-------|------|------|-------|--------|------|-------|------------|
| DRW:  | Dong | CHKD | Chang | MATL:  | Chui | DATE  | 04.12.2009 |
| APPD: | Ping |      |       | FINISH | Hui  | Sheet | 5 from 9   |



**Packing Specifications**

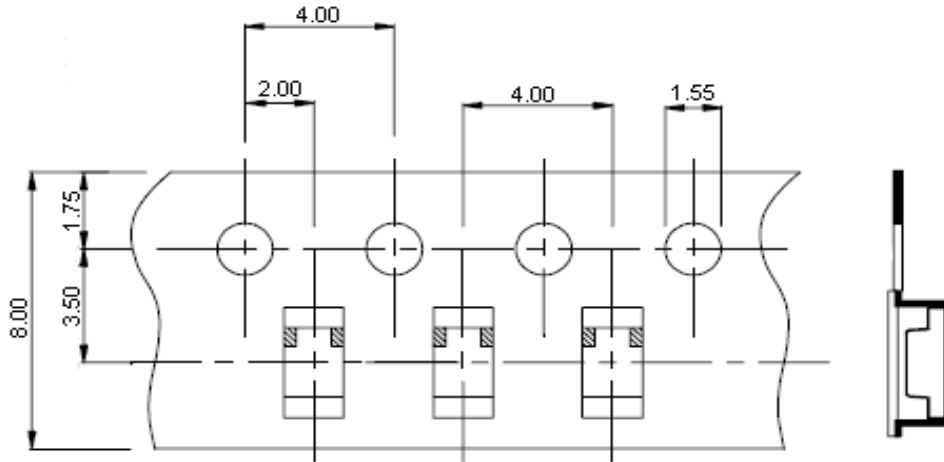

**Reel Specifications**

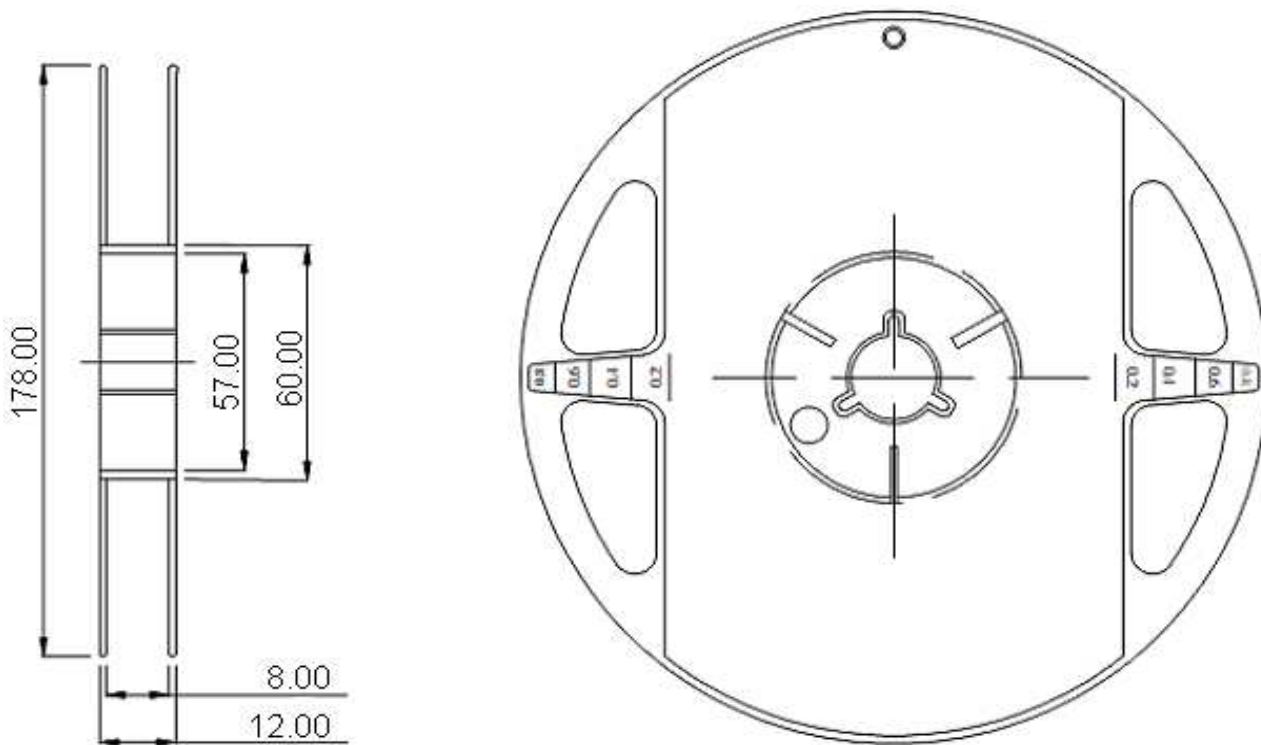

**SMT Top View LED**  
**Amber** **Blue**

Part No.: **M11C2009**

Customer:

|       |      |      |       |        |      |       |            |
|-------|------|------|-------|--------|------|-------|------------|
| DRW:  | Dong | CHKD | Chang | MATL:  | Chui | DATE  | 04.12.2009 |
| APPD: | Ping |      |       | FINISH | Hui  | Sheet | 6 from 9   |





**Handling Precautions**

Compare to epoxy encapsulant that is hard and brittle, silicone is softer and flexible. Although its characteristic significantly reduces thermal stress, it is more susceptible to damage by external mechanical force. As a result, special handling precautions need to be observed during assembly using silicone encapsulated LED products. Failure to comply might lead to damage and premature failure of the LED.

1. Handle the component along the side surfaces by using forceps or appropriate tools

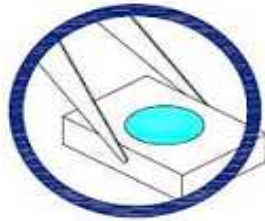

2. Do not directly touch or handle the silicone lens surface. It may damage the internal circuitry.



3. Do not stack together assembled PCBs containing exposed LEDs. Outside impact may scratch the silicone lens or damage the internal circuitry.



|                         |                 |
|-------------------------|-----------------|
| <b>SMT Top View LED</b> |                 |
| <i>Amber</i>            | <i>Blue</i>     |
| Part No.:               | <b>M11C2009</b> |
| Customer:               |                 |

|       |      |      |       |        |      |       |            |
|-------|------|------|-------|--------|------|-------|------------|
| DRW:  | Dong | CHKD | Chang | MATL:  | Chui | DATE  | 04.12.2009 |
| APPD: | Ping |      |       | FINISH | Hui  | Sheet | 7 from 9   |



4. The outer diameter of the TOP LED pickup nozzle should not exceed the size of the LED to prevent air leaks. The inner diameter of the nozzle should be as large as possible.
5. A pliable material is suggested for the nozzle tip to avoid scratching or damaging the LED surface during pickup.
6. The dimensions of the component must be accurately programmed in the pick-and-place machine to insure precise pickup and avoid damage during production.

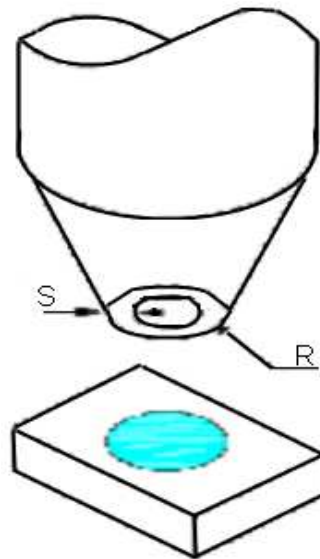

|                         |                 |
|-------------------------|-----------------|
| <b>SMT Top View LED</b> |                 |
| <b>Amber</b>            | <b>Blue</b>     |
| Part No.:               | <b>M11C2009</b> |
| Customer:               |                 |

|       |      |      |       |        |      |       |            |
|-------|------|------|-------|--------|------|-------|------------|
| DRW:  | Dong | CHKD | Chang | MATL:  | Chui | DATE  | 04.12.2009 |
| APPD: | Ping |      |       | FINISH | Hui  | Sheet | 8 from 9   |





**Color table curve**

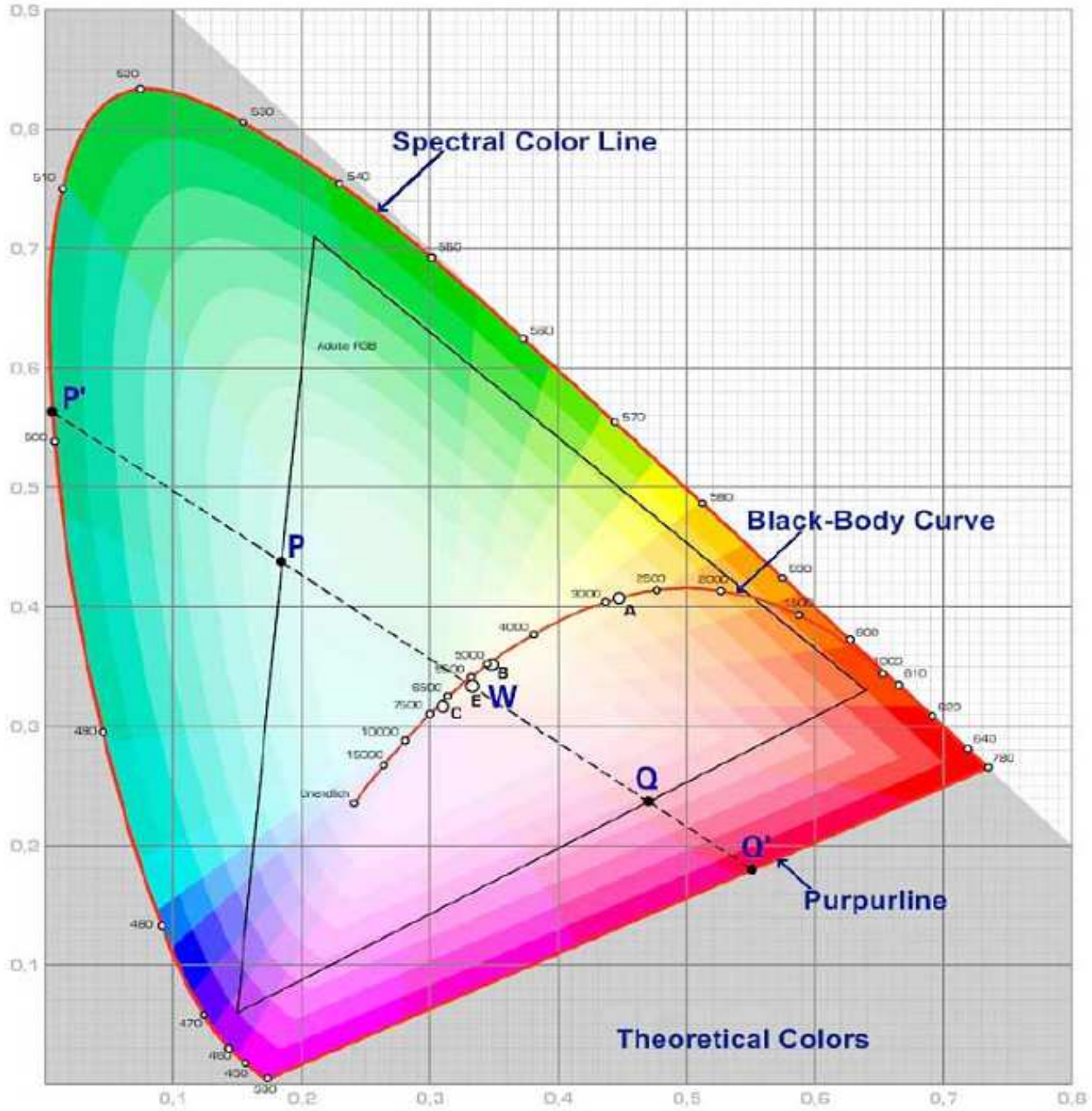

|                         |                 |
|-------------------------|-----------------|
| <b>SMT Top View LED</b> |                 |
| <b>Amber</b>            | <b>Blue</b>     |
| Part No.:               | <b>M11C2009</b> |
| Customer:               |                 |

|       |      |      |       |        |      |       |            |
|-------|------|------|-------|--------|------|-------|------------|
| DRW:  | Dong | CHKD | Chang | MATL:  | Chui | DATE  | 04.12.2009 |
| APPD: | Ping |      |       | FINISH | Hui  | Sheet | 9 from 9   |