

EDCON-COMPONENTS



Specifications

Min. Sound Pressure Level at 5V /10cm	87dB
Rated Voltage	5Volt
Operating Voltage	4~7Volt
Max. Consumption at 2,7KHz/7,2Vp.p. Square Wave	40mA/5Vdc
Resonant Frequency	2,40KHz
DC Resistance	45 +/-5Ω
Operating Temperature	. -40 ~ +85°C
Storage Temperature	. -40 ~ +85°C

Weight: 2,0gr.

This Label is removed after reflow soldering

Test Circuit

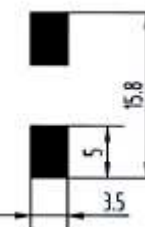
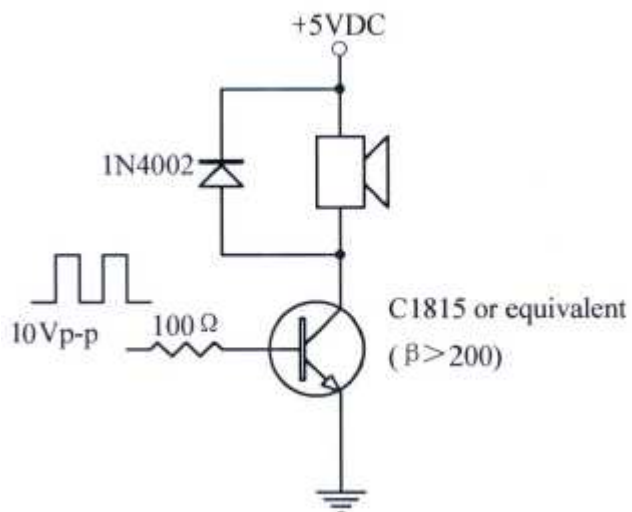

Features

This Item Is Designed For Surface Mounting Applications
 The Pin is plated with tin, which can meet the request of Reflow Soldering Process at 260°C for 30 Seconds
 Small Size item

Applications

PDA (Personal Digital Sssiatant)
 Miniature Electronic Devices

PCB Layout

SMD Magnetic Tranducer

Part No.: **Y14026**

Customer:

DRW:	Jason	CHKD	Wilson	MATL:	Wilson	TOLERANCE	Mason	DATE	10.06.2010
APPD:	Schumi			FINISH	Jamy		Sheet No.	1 from 4	

EDCON-COMPONENTS



Dimensions (mm)

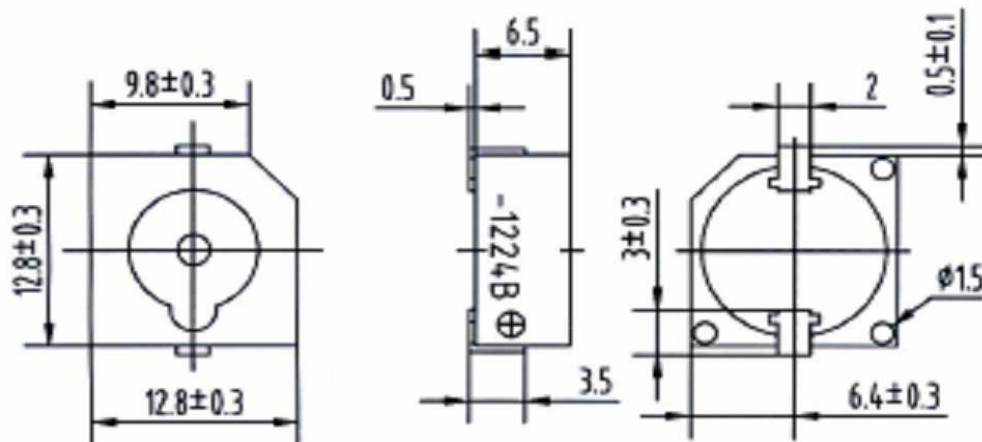

Characteristics

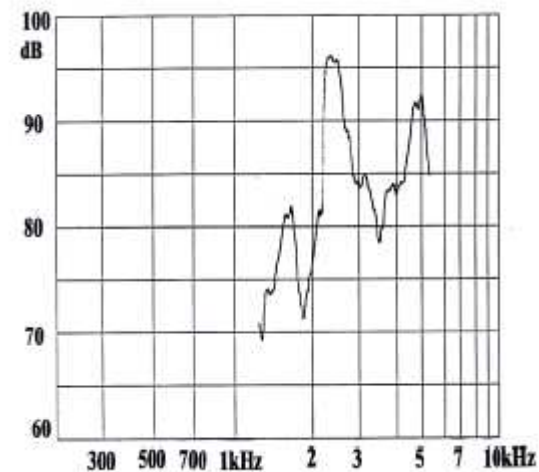

SMD Magnetic Transducer

Part No.: **Y14026**

DRW:	Jason	CHKD	Wilson	MATL:	Wilson	TOLERANCE	Mason	DATE	10.06.2010
APPD:	Schumi			FINISH	Jamy		Sheet No.	2 from 4	

Customer:

www.edcon-components.com

email: info@edcon-components.com

EDCON-COMPONENTS



Ordering Informations

Serie	Model-No.	ROHS	Package						
Y14026	1224B	R	TR						

R = ROHS Conform	TR = Tape Reel
N = NON ROHS Conform	TU = Tube Packing

SMD Magnetic Transducer	
Part No.:	Y14026
Customer:	

DRW:	Jason	CHKD	Wilson	MATL:	Wilson	TOLERANCE	Mason	DATE	10.06.2010
APPD:	Schumi			FINISH	Jamy		Sheet No.		3 from 4



Soldering Profile Curve

Classification Reflow Profile (JEDEC J-STD-020C)

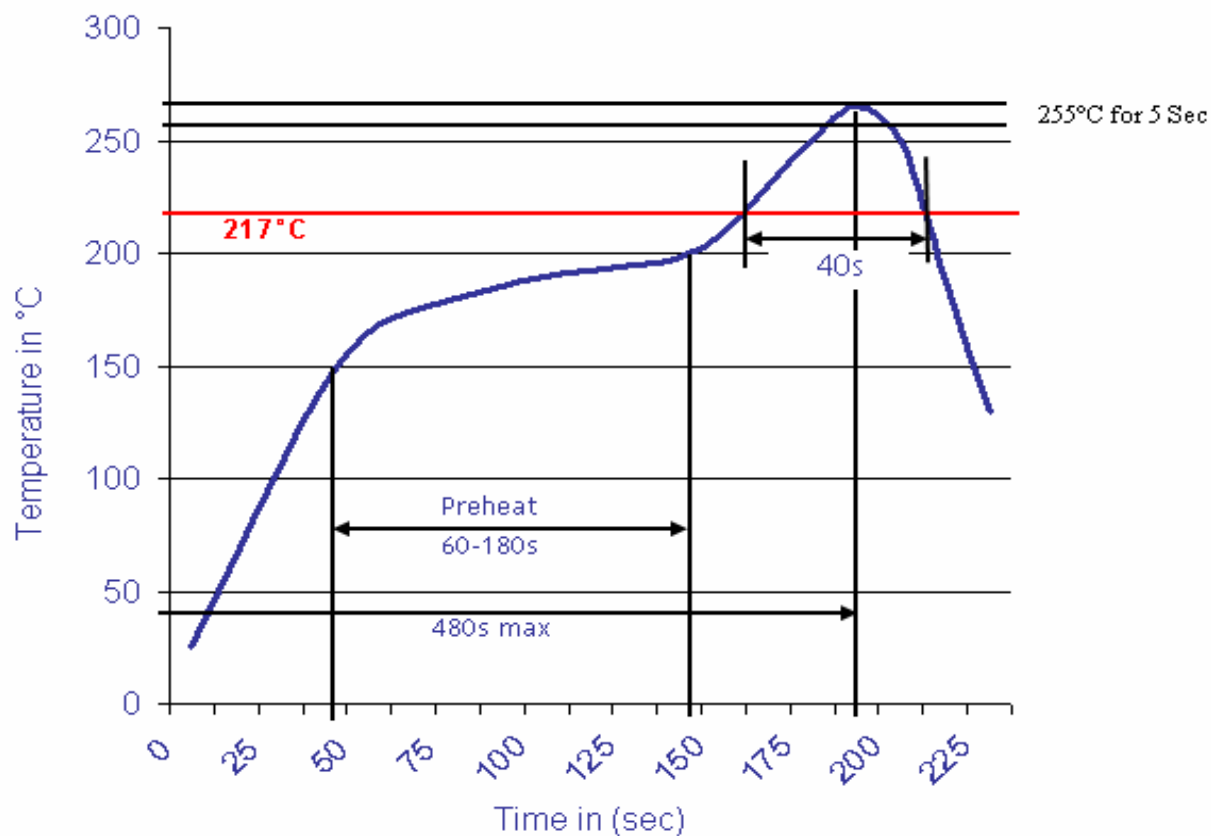

SMD Magnetic Tranducer	
Part No.:	Y14026
Customer:	

DRW:	Jason	CHKD	Wilson	MATL:	Wilson	TOLERANCE	Mason	DATE	10.06.2010
APPD:	Schumi			FINISH	Jamy		Sheet No.	4 from 4	