

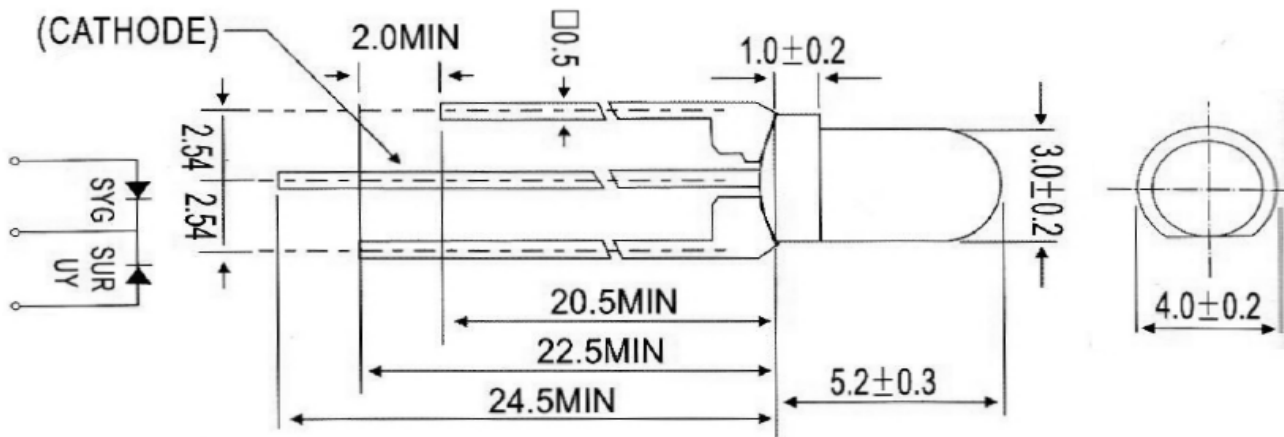

**Applications**

- Electronic Signs and Signals
- Small Area Illuminations
  - Back Lighting
  - Other Lighting

**Technical Drawing**



**Notes :**

All dimensions in mm tolerance is  $\pm 0.1\text{mm}$  unless otherwise noted.

<b>Round LED</b>	
<b>Yellow</b>	<b>Yellow Green</b>
Part No.:	<b>M13G9006</b>
Customer:	

DRW:	Ron	CHKD	Lang	MATL:	Chang	DATE	01.07.2010
APPD:	Xie			FINISH	Wang	Sheet	1 from 6



**Absolute Maximum Ratings**

Item	Symbol	---	---	Unit
Power Dissipation	P <sub>D</sub>		78	mW
DC Forward Current	I <sub>F</sub>		30	mA
Pulsed Forward Current	I <sub>FP</sub> *		100	mA
Reverse Voltage	V <sub>R</sub>		5	V
Operating Temperature	T <sub>OP</sub>		-30 to 85	°C
Storage Temperature	T <sub>ST</sub>		-40 to 100	°C

\* 0.1 msec pulse, 10% duty cycle

**Electrical / Optical Characteristics**

Emitting Color	Yellow		Yellow Green	
	---		---	
Material	---		---	
Forward Voltage	typ.	2.1	2.1	V <sub>F</sub>
	max.	2.6	2.6	V <sub>F</sub>
Wavelength typ.	λ <sub>D</sub>	585	565	nm
	λ <sub>P</sub>	590	570	nm
	Δλ	---	---	nm
Color Temperature	min.	---	---	K
	max.	---	---	K
Luminous Intensity *	min.	750	500	mcd
	typ.	1120	800	mcd
Reverse Current	max.		10	μA
Viewing Angle	2Θ <sub>1/2</sub>		30	

\* Per NIST standards

<b>Round LED</b>	
<b>Yellow</b>	<b>Yellow Green</b>
Part No.:	<b>M13G9006</b>
Customer:	

DRW:	Ron	CHKD	Lang	MATL:	Chang	DATE	01.07.2010
APPD:	Xie			FINISH	Wang	Sheet	2 from 6



**Directive Characteristics**

<b>Round LED</b> <b>Yellow                      Yellow Green</b>	
Part No.:	<b>M13G9006</b>
Customer:	

DRW:	Ron	CHKD	Lang	MATL:	Chang	DATE	01.07.2010
APPD:	Xie			FINISH	Wang	Sheet	3 from 6



**Typical Characteristics**

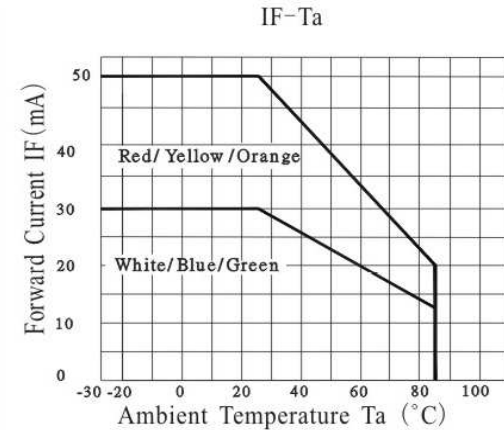
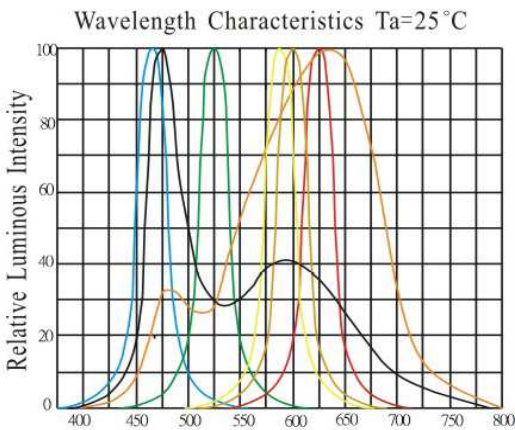
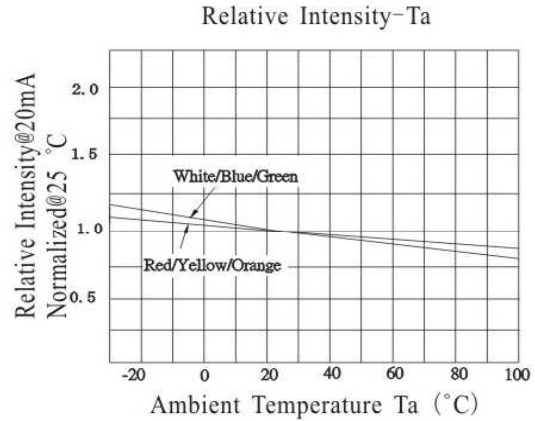
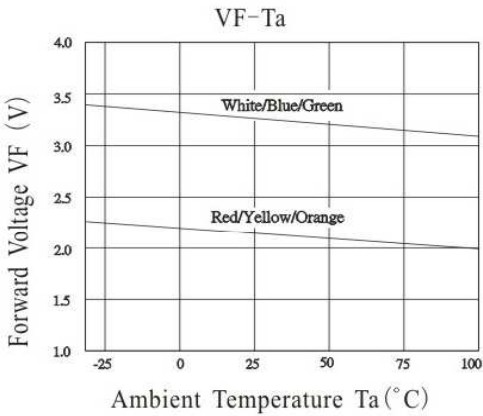
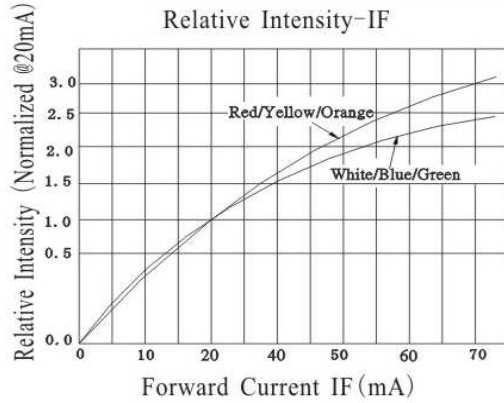
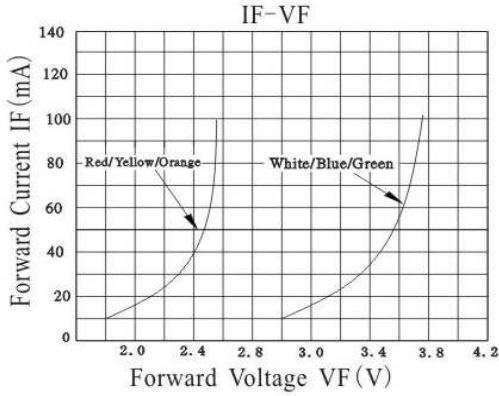

**Round LED**  
**Yellow                      Yellow Green**

Part No.: **M13G9006**

Customer:

DRW:	Ron	CHKD	Lang	MATL:	Chang	DATE	01.07.2010
APPD:	Xie			FINISH	Wang	Sheet	4 from 6



**Solder Condition**

**Lead Free Solder**

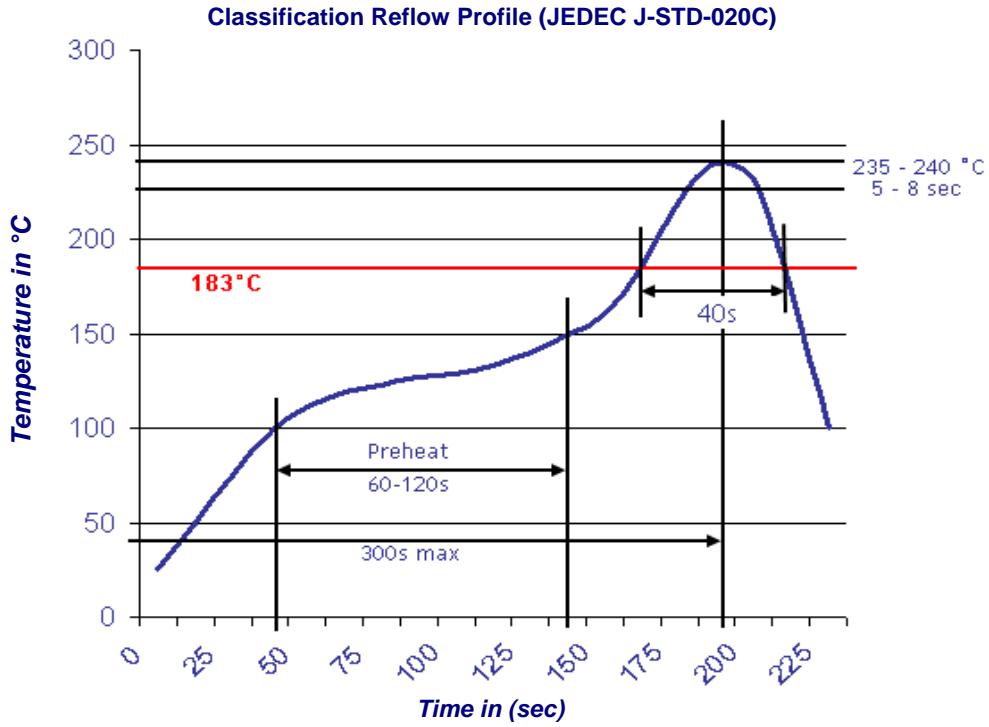

<b>Round LED</b>	
<b>Yellow</b>	<b>Yellow Green</b>
Part No.:	<b>M13G9006</b>
Customer:	

DRW:	Ron	CHKD	Lang	MATL:	Chang	DATE	01.07.2010
APPD:	Xie			FINISH	Wang	Sheet	5 from 6



**Color table curve**

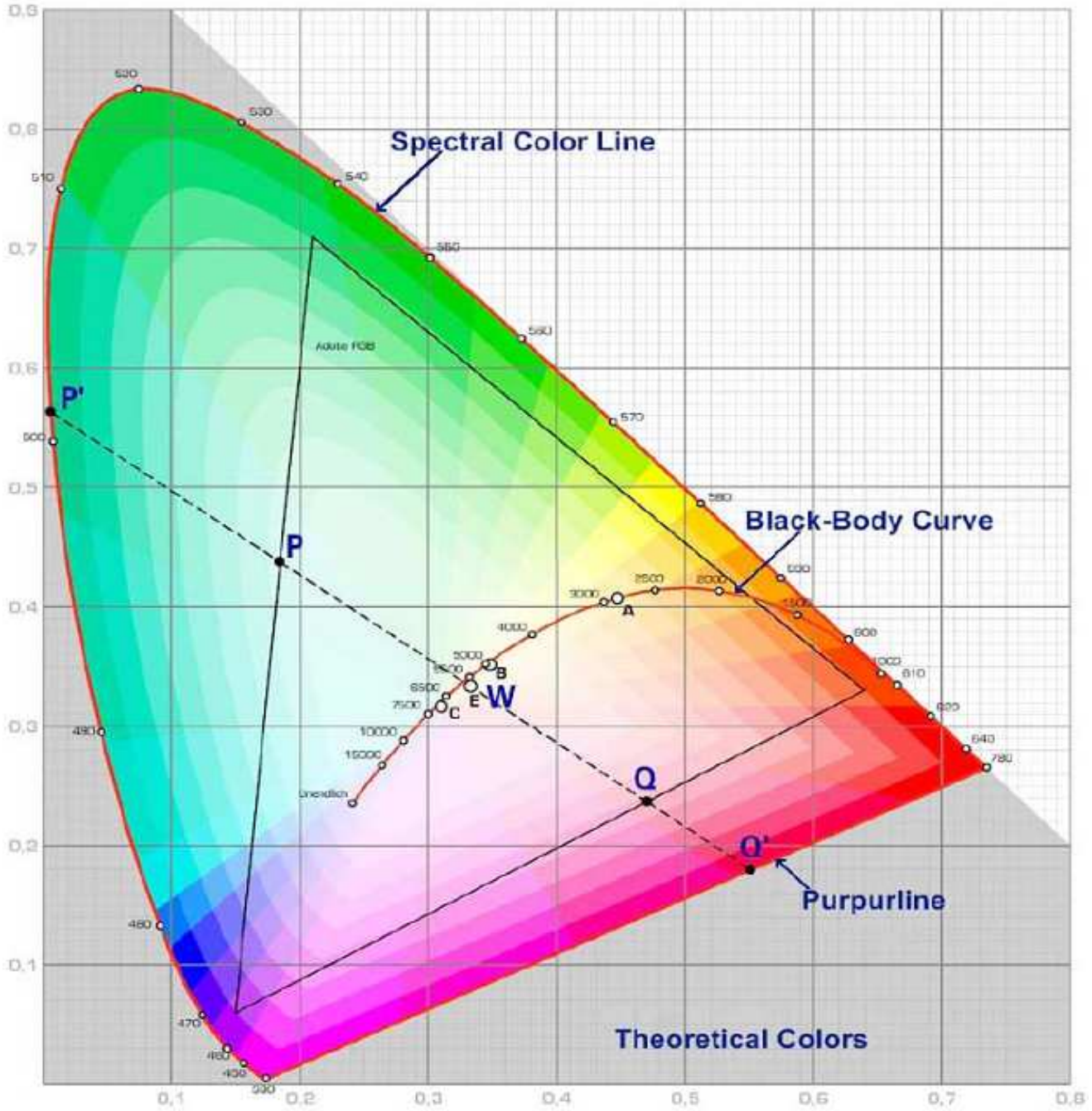

<b>Round LED</b>	
<b>Yellow</b>	<b>Yellow Green</b>
Part No.:	<b>M13G9006</b>
Customer:	

DRW:	Ron	CHKD	Lang	MATL:	Chang	DATE	01.07.2010
APPD:	Xie			FINISH	Wang	Sheet	6 from 6

Copyright by EDCON-COMPONENTS