

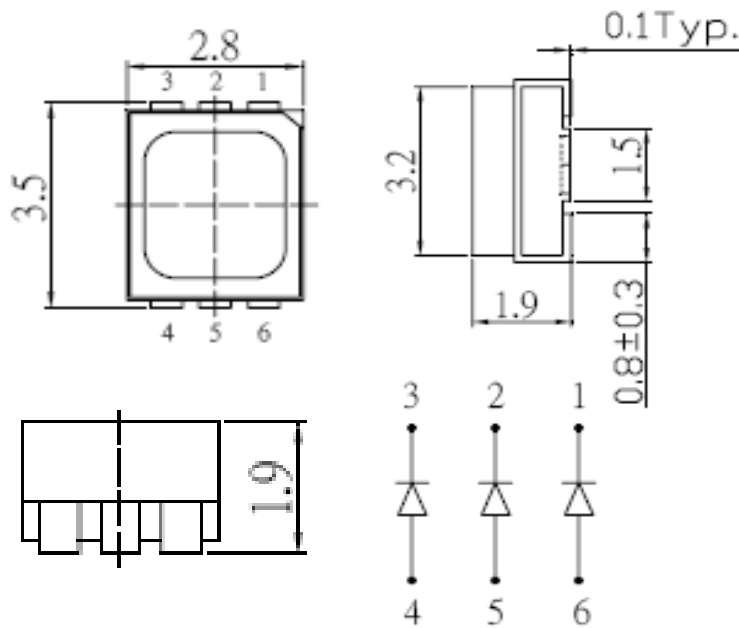

Applications

- Interior automotive lighting
- Optical indicators
- Communication Products
- Backlighting
- Toys

Technical Drawing



Notes :

All dimensions in mm tolerance is ± 0.1mm unless otherwise noted.

PLCC6 Orange	
Part No.:	M11D2009
Customer:	

DRW:	Dong	CHKD	Chang	MATL:	Chui	DATE	19.11.2010
APPD:	Ping			FINISH	Hui	Sheet	1 from 9



Absolute Maximum Ratings

Item	Symbol	---	Unit
Power Dissipation	P_D	234	mW
DC Forward Current	I_F	90	mA
Pulsed Forward Current	I_{FP}^*	100	mA
Reverse Voltage	V_R	5	V
Operating Temperature	T_{OP}	-30 to 85	°C
Storage Temperature	T_{ST}	-40 to 100	°C

* 0.1 msec pulse, 10% duty cycle

Electrical / Optical Characteristics

Ermitting Color	Orange		
Material	---		
Forward Voltage	typ.	2.1	V_F
	max.	2.6	V_F
Wavelength typ.	λ_D	600 ~ 610	nm
	λ_P	---	nm
	$\Delta\lambda$	---	nm
Color Temperature	min.	---	K
	max.	---	K
Luminous Intensity *	min.	2180	mcd
	typ.	3000	mcd
Reverse Current	max.	---	μA
Viewing Angle	$2\Theta_{1/2}$	120	

* Per NIST standards

PLCC6 Orange	
Part No.:	M11D2009
Customer:	

DRW:	Dong	CHKD	Chang	MATL:	Chui	DATE	19.11.2010
APPD:	Ping			FINISH	Hui	Sheet	2 from 9



Directive Characteristics

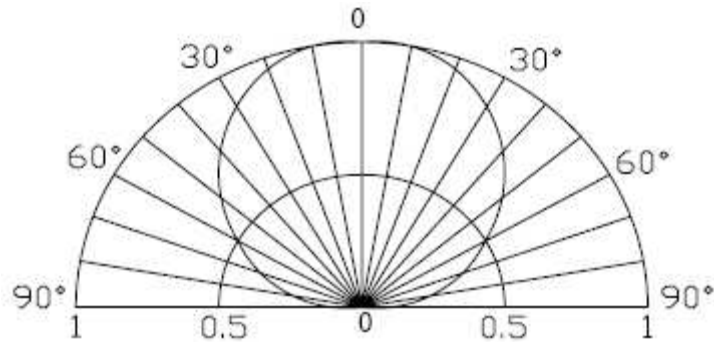

PLCC6 Orange	
Part No.:	M11D2009
Customer:	

DRW:	Dong	CHKD	Chang	MATL:	Chui	DATE	19.11.2010
APPD:	Ping			FINISH	Hui	Sheet	3 from 9



Typical Characteristics

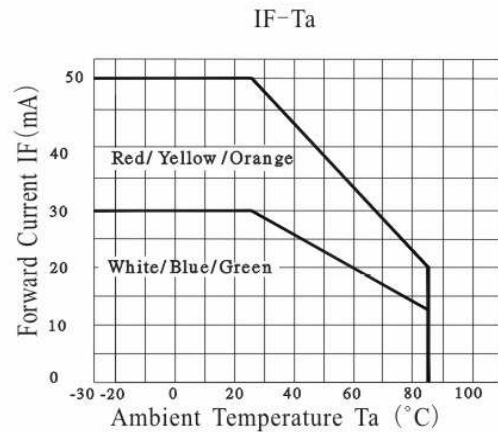
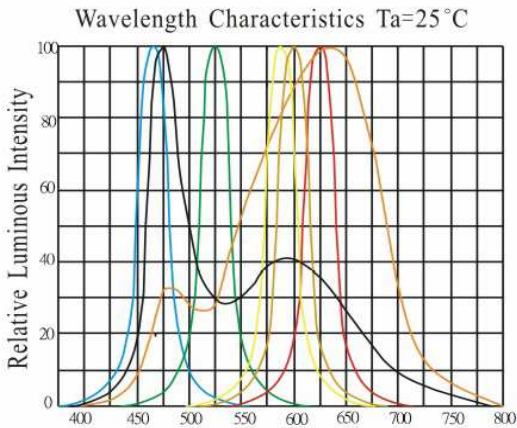
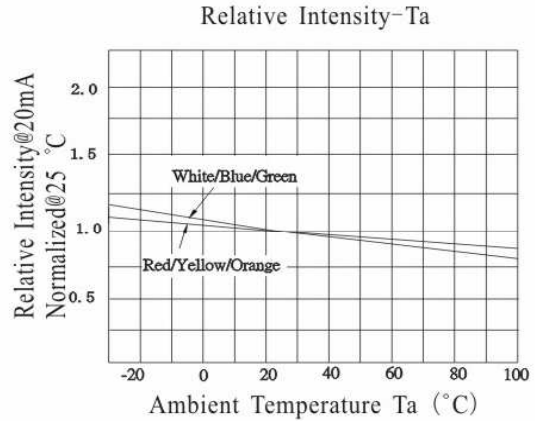
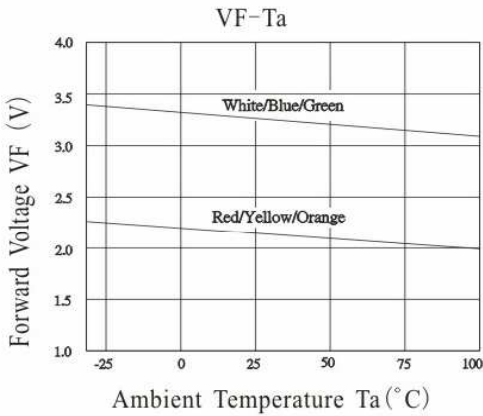
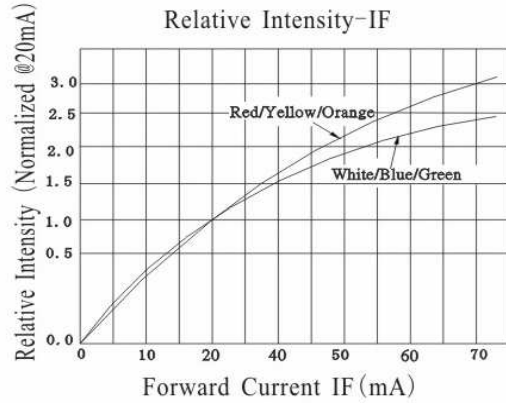
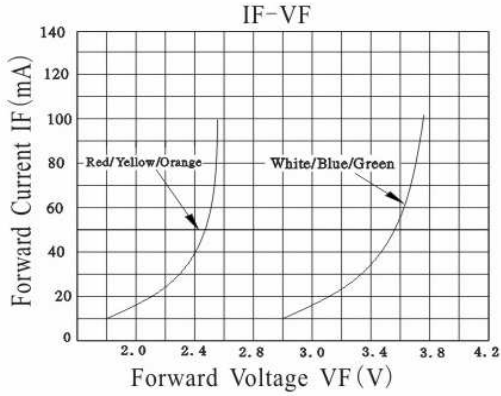

PLCC6 Orange	
Part No.:	M11D2009
Customer:	

DRW:	Dong	CHKD	Chang	MATL:	Chui	DATE	19.11.2010
APPD:	Ping			FINISH	Hui	Sheet	4 from 9



Solder Condition

Lead Free Solder

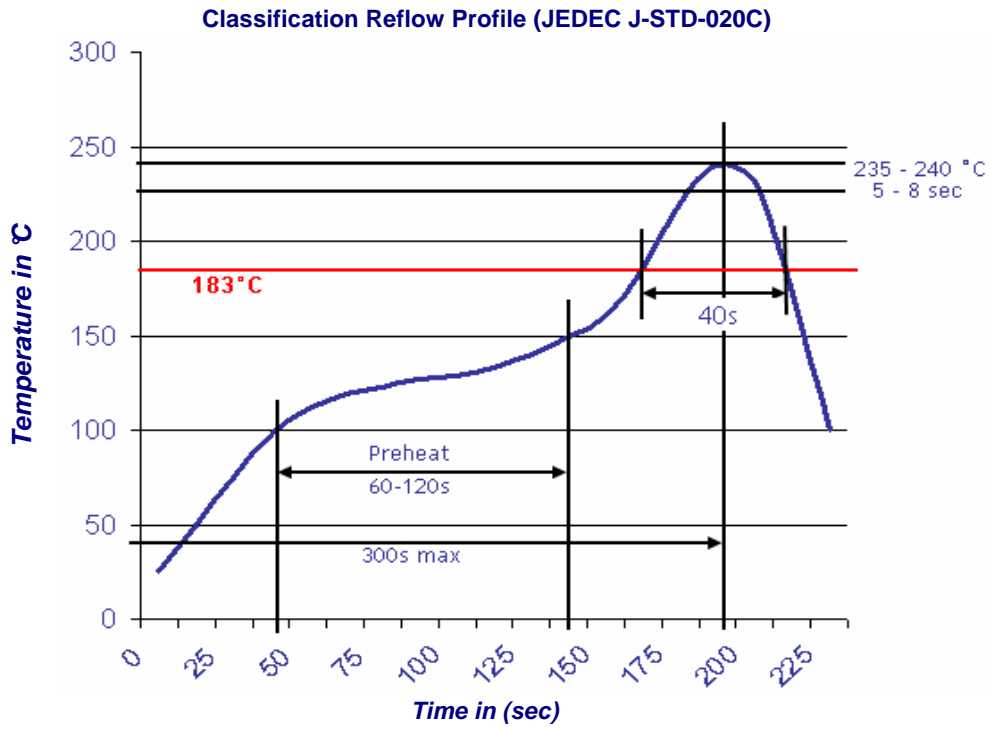

PLCC6 Orange	
Part No.:	M11D2009
Customer:	

DRW:	Dong	CHKD	Chang	MATL:	Chui	DATE	19.11.2010
APPD:	Ping			FINISH	Hui	Sheet	5 from 9



Packing Specifications

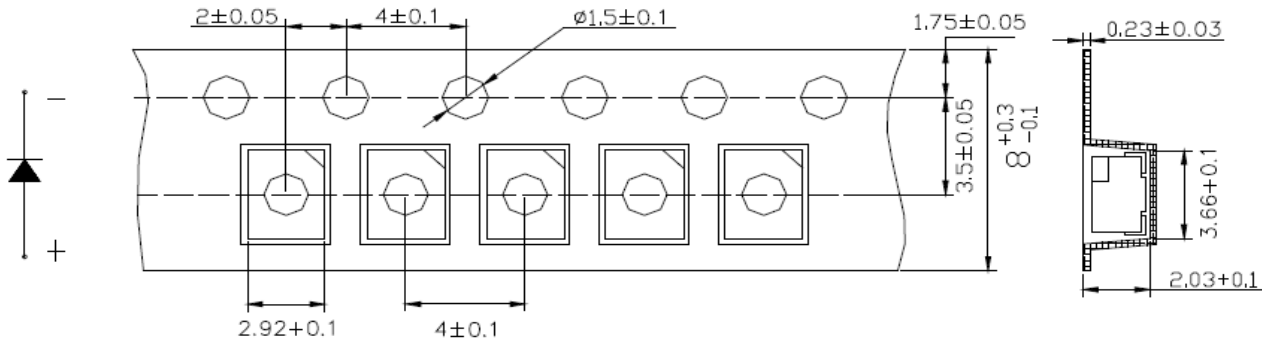

Reel Specifications

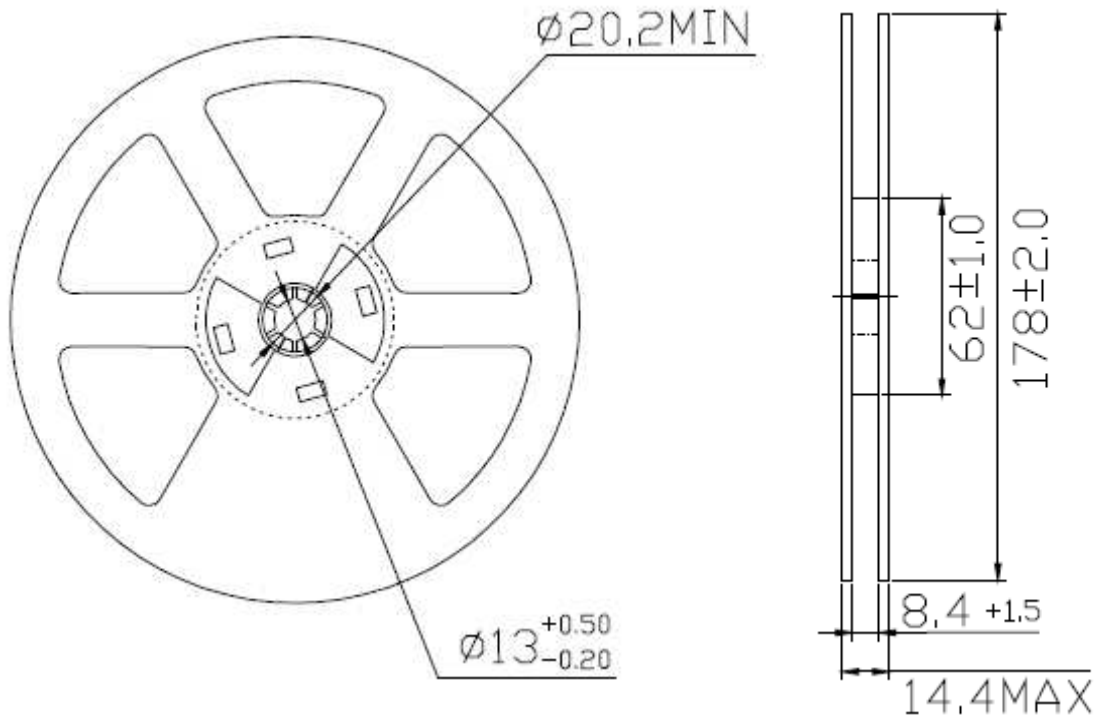

PLCC6 Orange	
Part No.:	M11D2009
Customer:	

DRW:	Dong	CHKD	Chang	MATL:	Chui	DATE	19.11.2010
APPD:	Ping			FINISH	Hui	Sheet	6 from 9



Handling Precautions

Compare to epoxy encapsulant that is hard and brittle, silicone is softer and flexible. Although its characteristic significantly reduces thermal stress, it is more susceptible to damage by external mechanical force. As a result, special handling precautions need to be observed during assembly using silicone encapsulated LED products. Failure to comply might lead to damage and premature failure of the LED.

1. Handle the component along the side surfaces by using forceps or appropriate tools

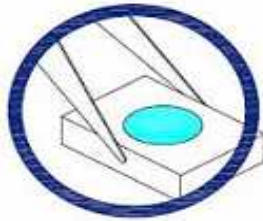

2. Do not directly touch or handle the silicone lens surface. It may damage the internal circuitry.



3. Do not stack together assembled PCBs containing exposed LEDs. Outside impact may scratch the silicone lens or damage the internal circuitry.



PLCC6
Orange

Part No.: **M11D2009**

Customer:

DRW:	Dong	CHKD	Chang	MATL:	Chui	DATE	19.11.2010
APPD:	Ping			FINISH	Hui	Sheet	7 from 9



4. The outer diameter of the TOP LED pickup nozzle should not exceed the size of the LED to prevent air leaks. The inner diameter of the nozzle should be as large as possible.
5. A pliable material is suggested for the nozzle tip to avoid scratching or damaging the LED surface during pickup.
6. The dimensions of the component must be accurately programmed in the pick-and-place machine to insure precise pickup and avoid damage during production.

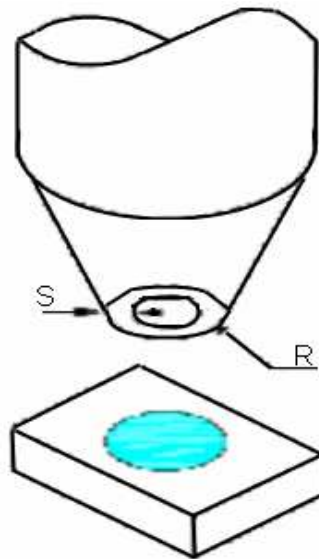

PLCC6 Orange	
Part No.:	M11D2009
Customer:	

DRW:	Dong	CHKD	Chang	MATL:	Chui	DATE	19.11.2010
APPD:	Ping			FINISH	Hui	Sheet	8 from 9



Color table curve

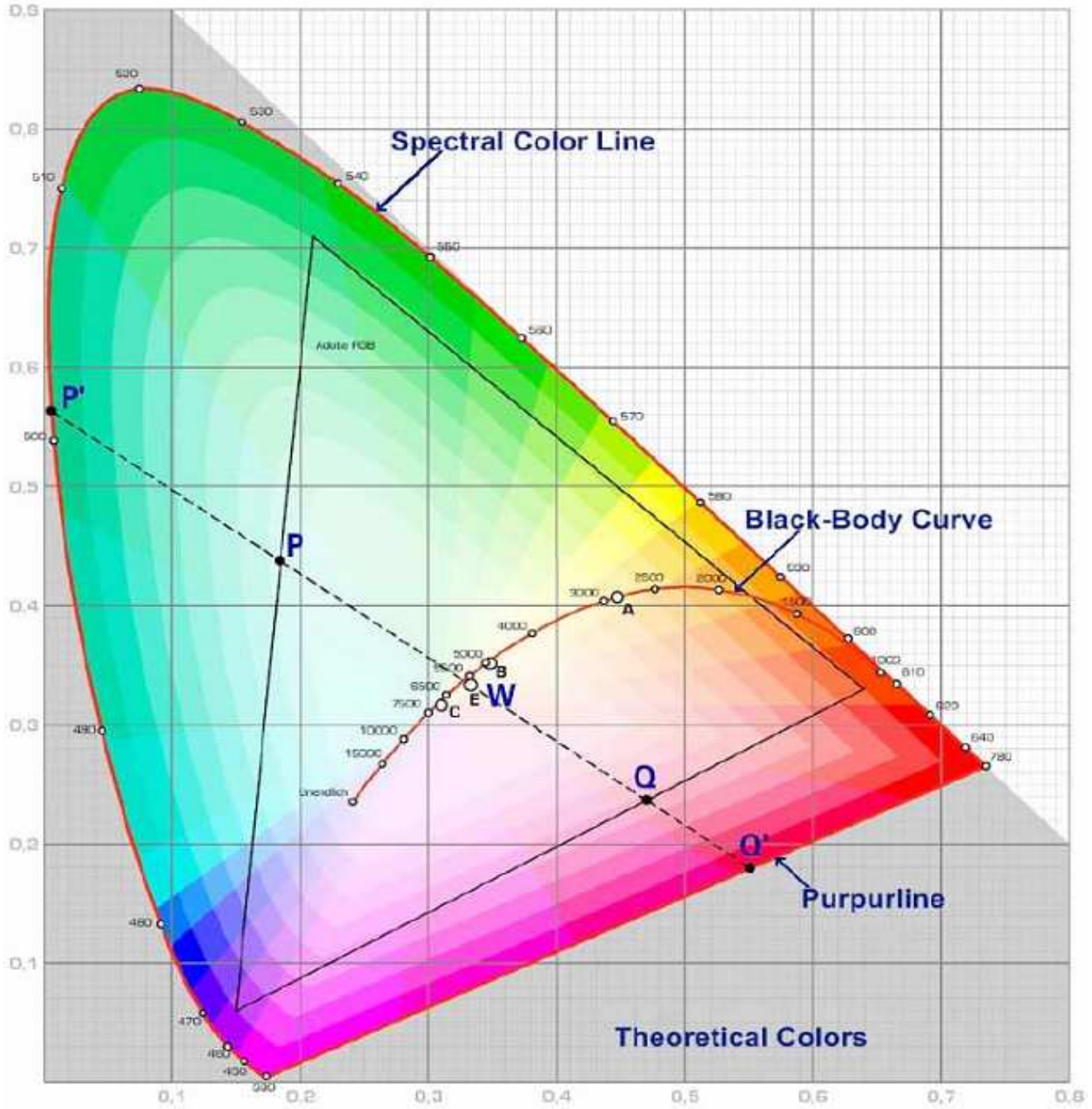

PLCC6 Orange	
Part No.:	M11D2009
Customer:	

DRW:	Dong	CHKD	Chang	MATL:	Chui	DATE	19.11.2010
APPD:	Ping			FINISH	Hui	Sheet	9 from 9

Copyright by EDCON-COMPONENTS