

EDCON-COMPONENTS



Contact



SPECIFICATION:

Materials:	Die-casting aluminium alloy
Color:	Alloy
Interlocking Components:	Stainless stell or galvanized steel button
Galvanized Steel:	IP65
Temperatur Range:	.-40°C to +125°C
Flammability acc:	VO (UL94)
Cable Entry:	SIDE One Lever

Technical Drawing

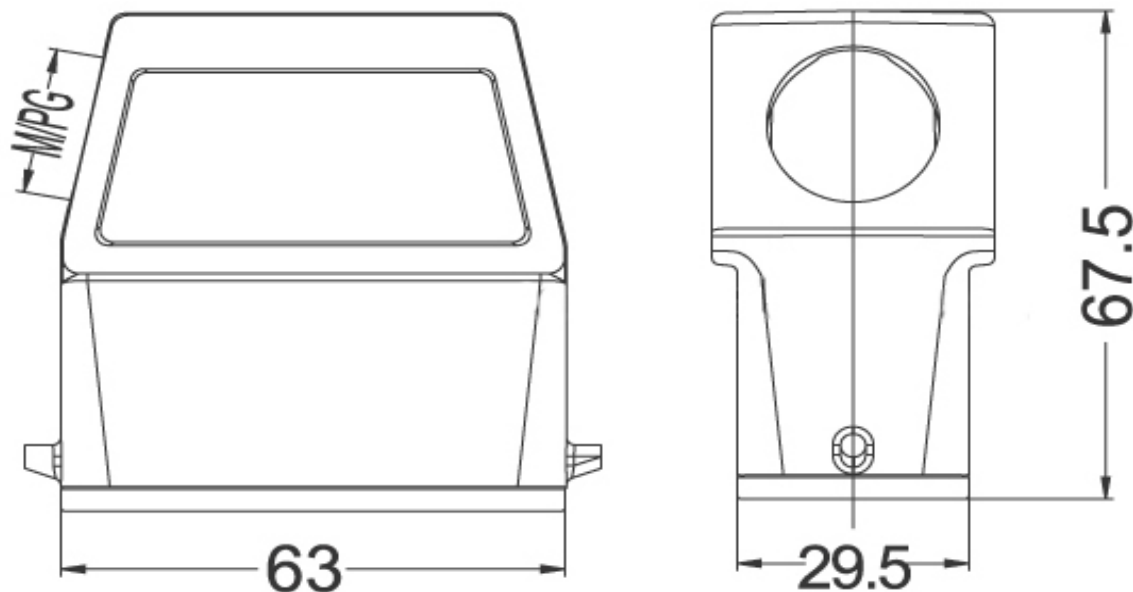

Heavy Connector Hood Serie 0913

Part No.: **0913004**

Customer:

DRW:	Jason	CHKD	Wilson	MATL:	Wilson	TOLERANCE	Mason	DATE	01.08.2009
APPD:	Schumi			FINISH	Jamy		Sheet No.	1 from 2	

www.edcon-components.com

email: info@edcon-components.com

EDCON-COMPONENTS



Contact



Ordering Informations

Serie	Thread Type	Size of Thread	ROHS	Packing						
0913004	M	25	R	CA						

M= M-Thread	25 = M25	R= ROHS Conform	CA= Carton				
P= PG Thread	16= PG16	N= NON ROHS Conform					
	21= PG21						

Heavy Connector Hood Serie 0913	
Part No.:	0913004
Customer:	

DRW:	Jason	CHKD	Wilson	MATL:	Wilson	TOLERANCE	Mason	DATE	02.02.2008
APPD:	Schumi			FINISH	Jamy		Sheet No.		2 from 2