

EDCON-COMPONENTS



Technical Discription

Electrical

Current Rating: 1,5A
 Voltage Rating: 125VAC
 Insulation Resistance: 500M Ω min.
 Contact Resistance: 30M Ω max.
 Withstanding Voltage: AC1000V RMS 50/60Hz 1min.

Mechanical

Insertion Force: 2,2Kg.F.max.
 Retention Strength: 7,7Kg.F min.between jack a. plug
 Durability: 600 mating cycles min.

Material

Housing: ABS RESIN (UL94V-0)
 PBT(UL94V-0 PA66(U094V-0)
 PA46(UL94V-0)
 Diameter 0,45mm Phosphor
 Bronze Gold Plating over Nickel
 Contact wire: 0,35mm thickness phosphor
 bronze alloy selective Gold plating
 over nickel
 Shield 0,20~0,25mm thickness brass with
 tin plated
 Contact Plating Gold Flash, 3 μ / 6 μ / 15 μ / 30 μ 50 μ
 inch
 Working Temperatur . -40 $^{\circ}$ C ~ +70 $^{\circ}$ C

Technical Drawing

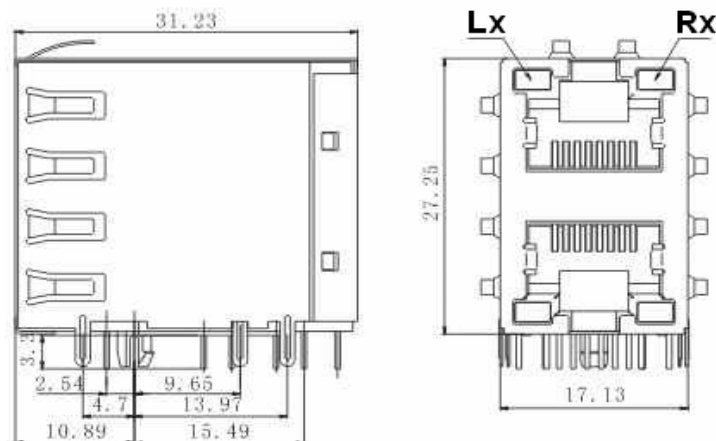

PCB Layout

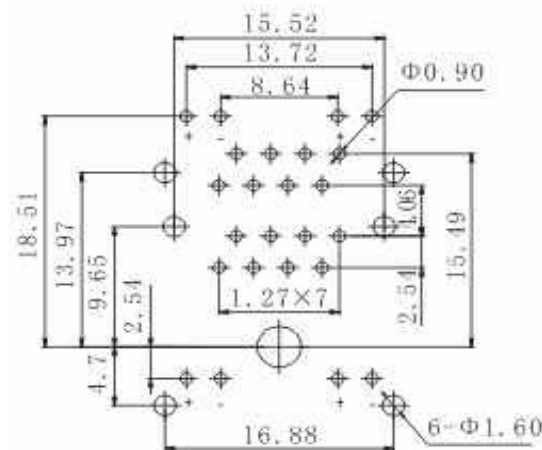

**LED PCB Modular Jack w.
shield w/o flange**

Part No.: **T91A26005**

Customer:

DRW:	John	CHKD	Tony	MATL:	Tony	TOLERANCE	Su	DATE	10.04.2009
APPD:	Jimmy			FINISH	Jeff		Sheet No.		1 from 3

www.edcon-components.com

email: info@edcon-components.com

EDCON-COMPONENTS



Ordering Informations

Serie	No. Of. Positions	No. Of Contact	Left Side LED	Right Side LED	Contact Plating	ROHS	Packing			
T91A26005	8	8	LC	RB	GF	R	TY			

8= 8Pos.	8= 8Pos. connecting	LA= Red	RA= Red	GF= Gold Flash	R= ROHS conform	TY= Tray Packing
		LB= Green	RB= Green	GA= 3µGold Plating	N= NON ROHS conform	BU= Bulk-Ware
		LC= Yellow	RC= Yellow	GB= 6µGold Plating		
				GC= 15µGold Plating		
				GD= 30µGold Plating		
				GE= 50µGold Plating		

LED PCB Modular Jack w. shield w/o flange	
Part No.:	T91A26005
Customer:	

DRW:	John	CHKD	Tony	MATL:	Tony	TOLERANCE	Su	DATE	10.04.2009
APPD:	Jimmy			FINISH	Jeff		Sheet No.		2 from 3

www.edcon-components.com

email: info@edcon-components.com

Copyright by EDCON-COMPONENTS H.Schmitt

EDCON-COMPONENTS



Soldering Profile Curve

Lead Free Soldering Curve

Classification Reflow Profile (JEDEC J-STD-020C)



LED PCB Modular Jack w. shield w/o flange	
Part No.:	T91A26005
Customer:	

DRW:	John	CHKD	Tony	MATL:	Tony	TOLERANCE	Su	DATE	10.04.2009
APPD:	Jimmy			FINISH	Jeff		Sheet No.	3 from 3	