

EDCON-COMPONENTS

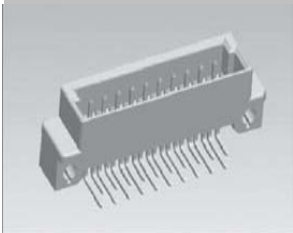

Specifications

Current Rating: 2,0A
 Operating Temperature: -55°C ~ + 105°C
 Contact Resistance: 20 M Ω max.
 Withstanding Voltage: AC 1000V for 1 Minute
 Insulation Resistance: 100000M Ω min at DC100V

 Contact Material: Brass
 Contact Plating: Au or Sn over Ni
 Insulator Material: PBT 30%GF UL 94V-0
 Insertion Force: 20Pin max. 18N
 Withdrawal Force: 0,15N min per individ. Contact

Drawing (dimensions all into mm)

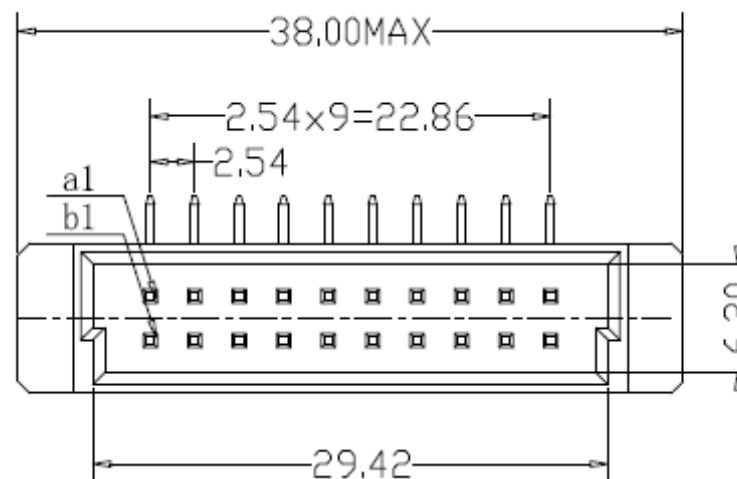

PCB Layout

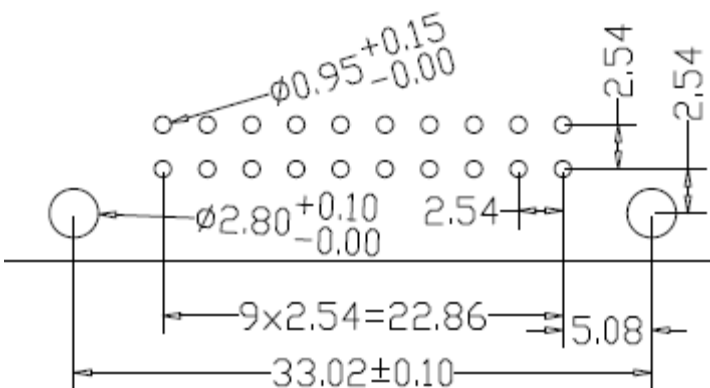

DIN41612 Connector 1/3 Size Type B Male R/A	
Part No.:	T21001-
Customer:	

DRW:	Jason	CHKD	Wilson	MATL:	Wilson	TOLERANCE	Mason	DATE	18.02.2017
APPD:	Schumi			FINISH	Jamy		Sheet No.		1 from 4

EDCON-COMPONENTS

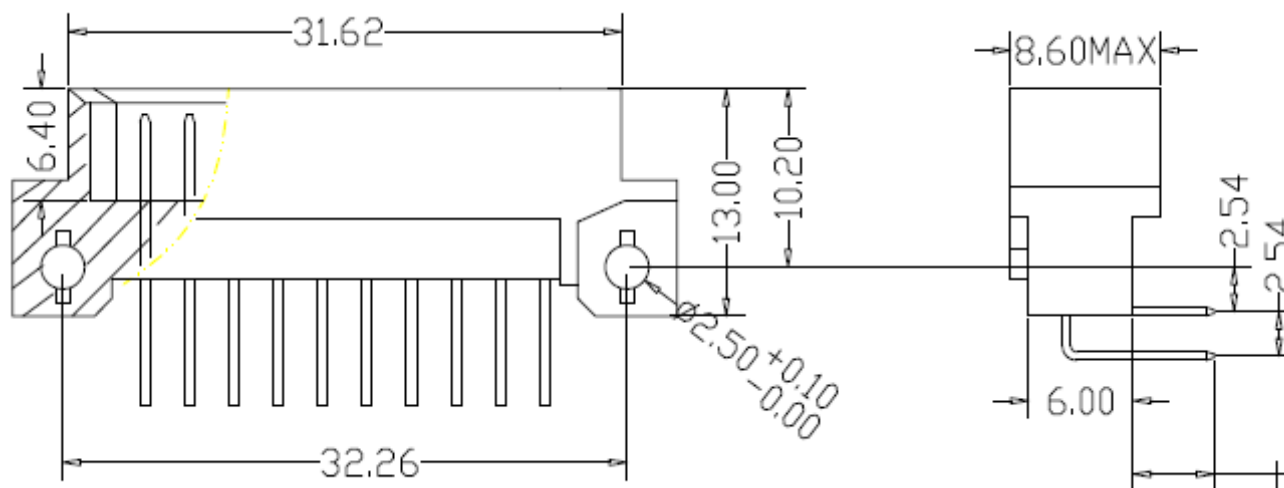
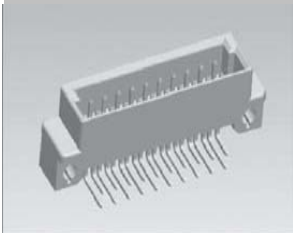

**DIN41612 Connector 1/3 Size
Type B Male R/A**

Part No.: **T21001-**

Customer:

DRW:	Jason	CHKD	Wilson	MATL:	Wilson	TOLERANCE	Mason	DATE	18.02.2017
APPD:	Schumi			FINISH	Jamy		Sheet No.	2 from 4	

EDCON-COMPONENTS

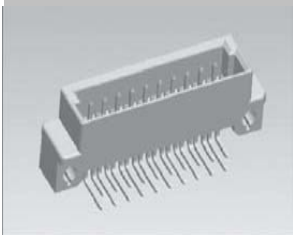

Ordering Informations

Serie	Loaded Contacts	Termination Specification	Row Loaded Contacts	Contact Plating	Special function	Special function	ROHS	Packing		
T21001-	10	A1	A0	S0	N	N	R	BU		

10 = Pos.	A1=Solder H=3,0mm	A0= Only Row A	G0= Gold Flash	N= No Special	N= No Special	R= ROHS Conform	BU= Bulk Packing		
20 = Pos.	A2=Solder H=4,4mm	B0= Row A + B	S0= Selectiv Gold Flash/Ni			N= NON ROHS	TY= Tray Packing		
			G1= 3µ AU Gold				IV= Individual Packing		
			G2= 5µ AU Gold						
	A5=Wrap H=13mm	C2= Row A+B 2,4,6...	G3= 10µ AU Gold						
			G4= 15µ AU Gold						
			G5= 30µ AU Gold						
			S1= 3µ AU Gold / Ni	S4= 15µ AU Gold / Ni					
			S2= 5µ AU Gold / Ni	S5= 30µ AU Gold / Ni					
			S3= 10µ AU Gold / Ni	TN= Tin Plated					

**DIN41612 Connector 1/3 Size
Type B Male R/A**

Part No.: **T21001-**

Unless Otherwise specified tolerance					
X=± 0,35	X.X=± 0,25	X.XX=± 0,20	X.XXX=± 0,15		
DRW: Jason	CHKD: Wilson	MATL: Wilson	TOLERANCE: Mason	DATE: 18.02.2017	
APPD: Schumi	FINISH: Jamy		Sheet No.:	3 from 4	Customer:

www.edcon-components.com

email: info@edcon-components.com

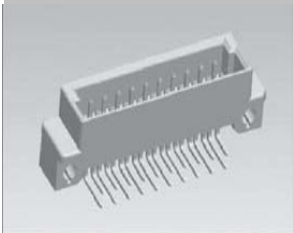

Soldering Informations

Classification Reflow Profile (JEDEC J-STD-020C)

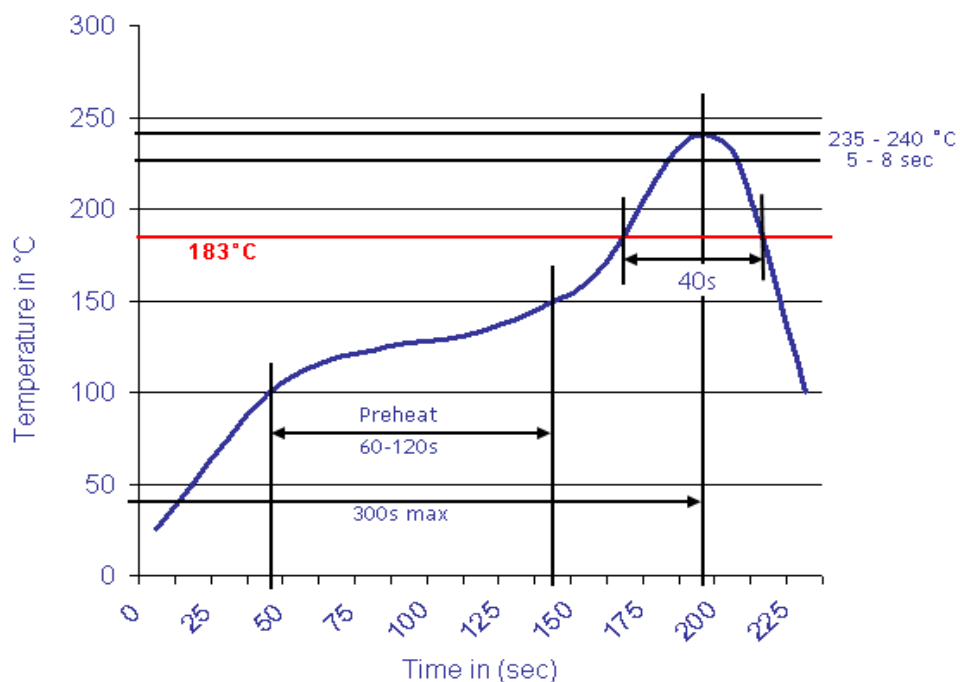

Classification Reflow Profile (JEDEC J-STD-020C)

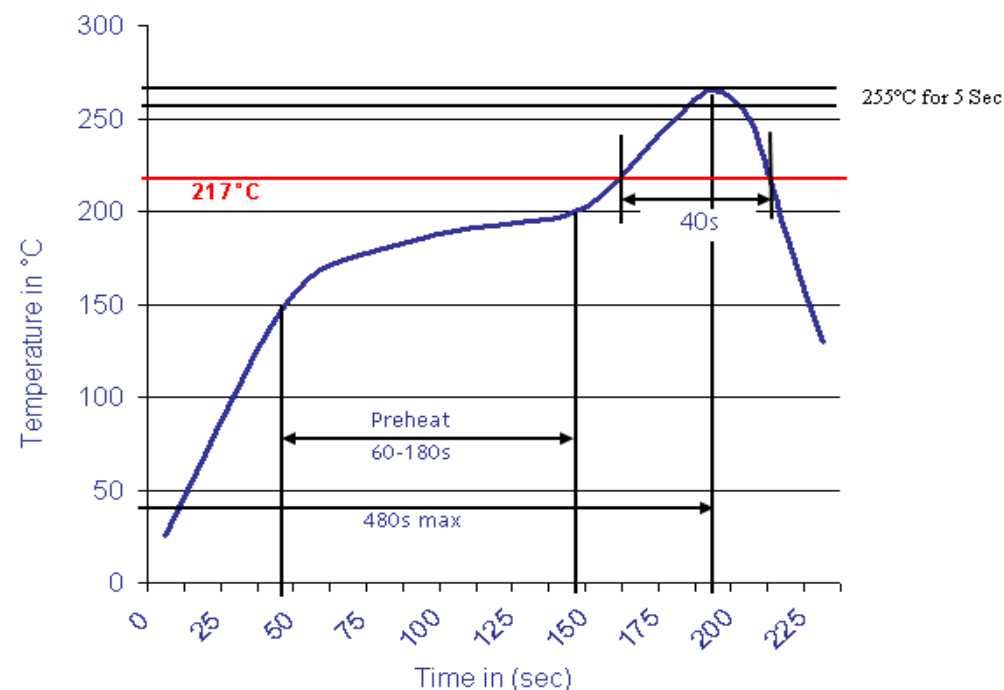

DIN41612 Connector 1/3 Size
Type B Male R/A

Part No.: T21001-

DRW:	Jason	CHKD	Wilson	MATL:	Wilson	TOLERANCE	Mason	DATE	18.02.2017
APPD:	Schumi			FINISH	Jamy		Sheet No.	4 from 4	Customer: