

MATERIAL	FLAMMABILITY RATING	CONTINUOUS OPERATING TEMP.
ABS	UL94-HB	-40°C ~ +60°C / -40°F ~ 140°F
CLEAR PC	UL94-V0 UV STABILIZED	-40°C ~ +130°C / -40°F ~ 266°F
ABS / PC BLEND	UL94-5VA	-40°C ~ +85°C / -40°F ~ 185°F
PBT / PC BLEND	UL94-5VA + UV (f1)	-40°C ~ +75°C / -40°F ~ 167°F

FINISH:
 BODY _____ LIGHT GRAY
 COVER _____ LIGHT GRAY OR CLEAR
 LATCHES & HINGES _____ PLASTIC
 WALL MOUNTING BRACKETS _____ STAINLESS STEEL & HARDWARE

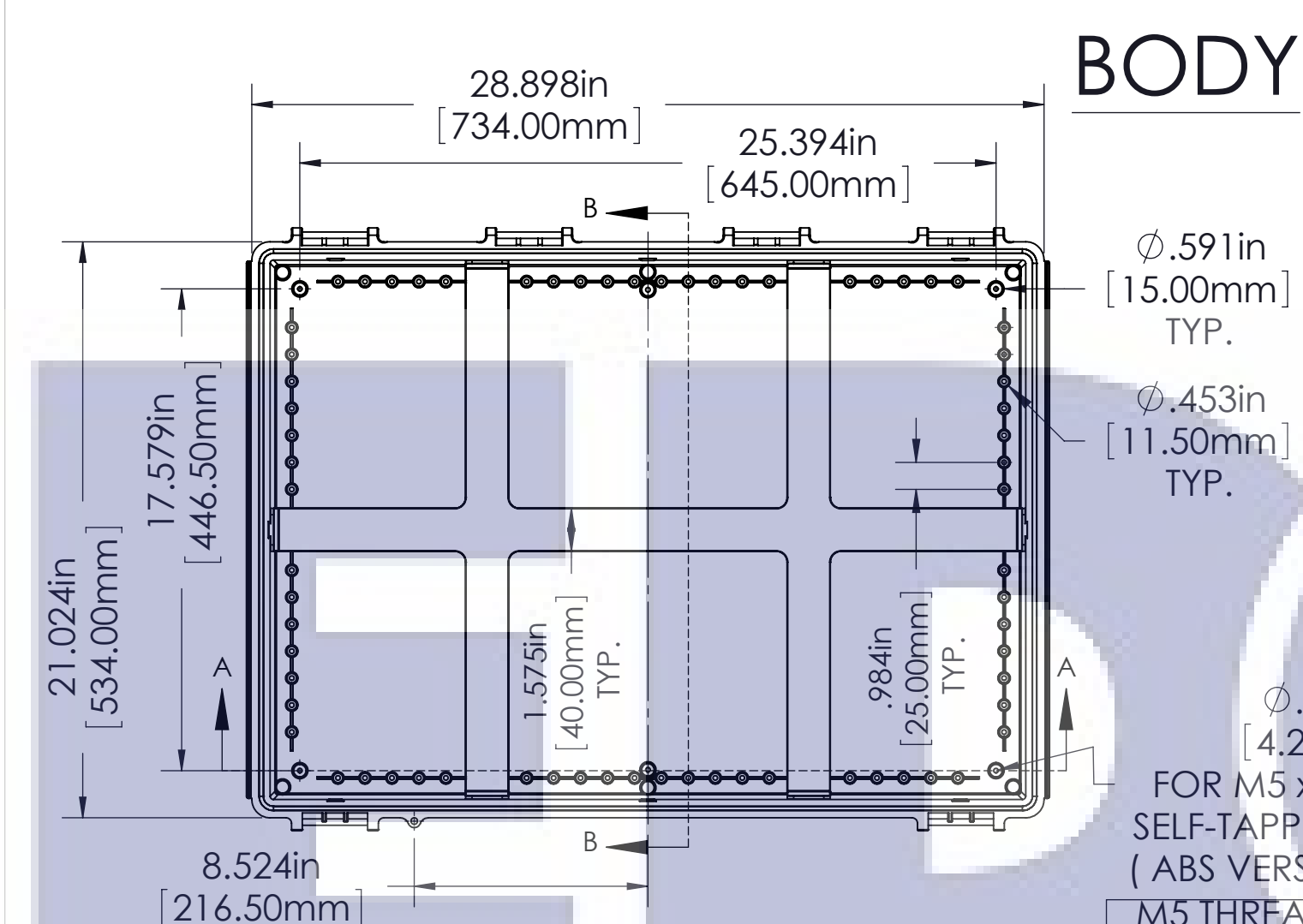

BODY

Ø.591in [15.00mm] TYP.
 Ø.453in [11.50mm] TYP.
 Ø.165in [4.20mm] FOR M5 x 10mm LG. SELF-TAPPING SCREWS (ABS VERSIONS ONLY) M5 THREADED INSERTS ON ALL OTHER VERSIONS USE M5 x 8mm LG. MACHINE SCREWS.

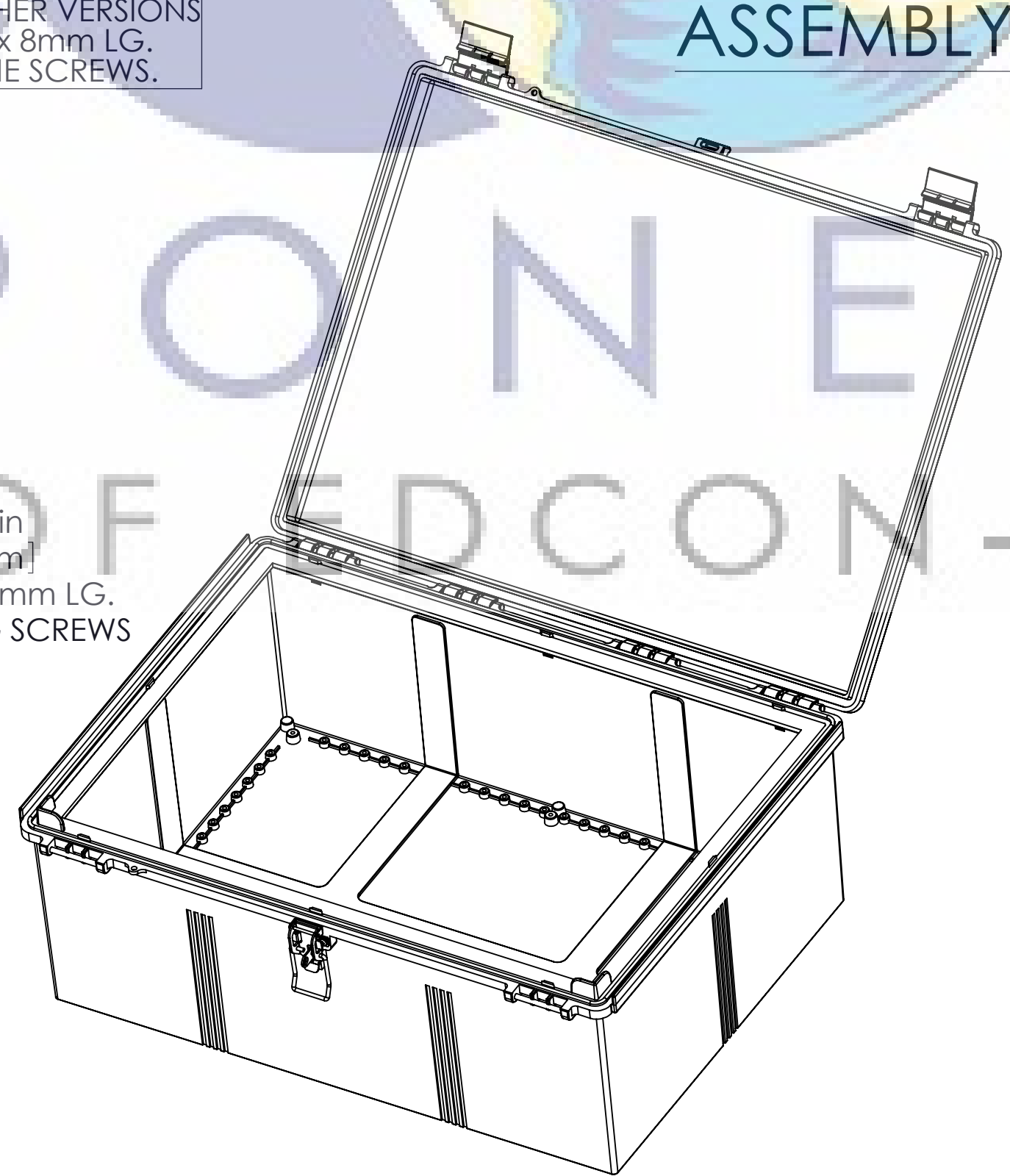

ASSEMBLY

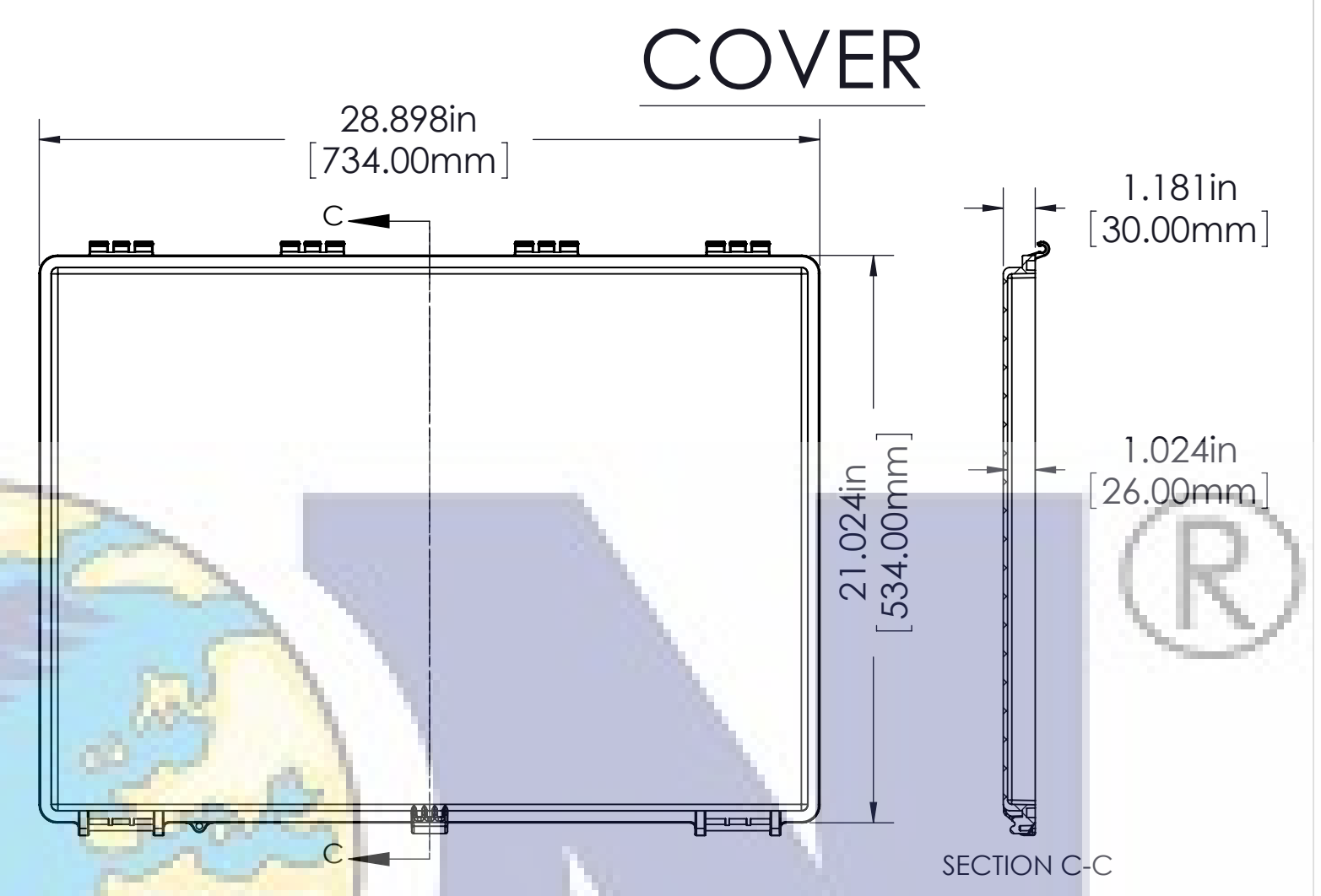

COVER

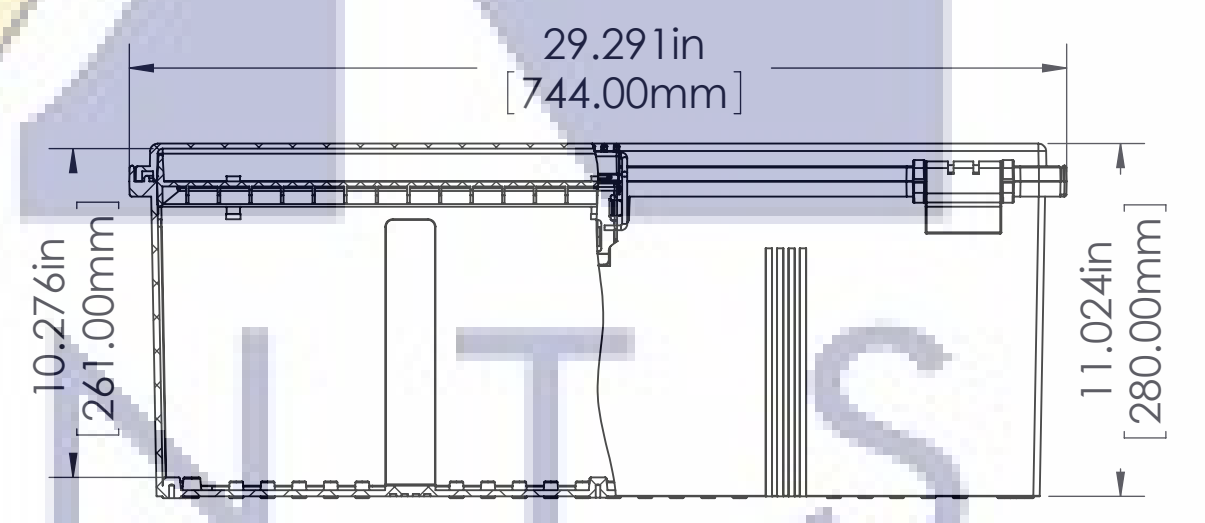

- NOTES:
- 1) UNIT COMES COMPLETE WITH (4) WALL MOUNTING BRACKETS & (4) M5 x 10mm LG. SELF-TAPPING SCREWS. (NOT SHOWN)
 - 2) BOXES DESIGNED TO MEET THESE STANDARDS: NEMA 1,2,4,4X, AND IEC529-IP65 REQUIREMENTS.

TOLERANCE:
 ALL DIMENSIONS HAVE ±0.039in [±1mm] TOLERANCE UNLESS OTHERWISE SPECIFIED.

PART NO.	MATERIAL		USE
	BODY	COVER	
EN-AG-5070	ABS	ABS	INDOOR
EN-AT-5070	ABS	CLEAR PC	INDOOR
EN-PG-5070	ABS / PC	ABS / PC	INDOOR
EN-PT-5070	ABS / PC	CLEAR PC	INDOOR
EN-PCG-5070	PBT / PC	PBT / PC	OUTDOOR
EN-PCT-5070	PBT / PC	CLEAR PC	OUTDOOR

EDCON-COMPONENTS



Ordering Informations

Serie	Material Body	Color Body	Material Cover	Color Cover	ROHS	Packing				
H37025	AB	LG	AB	LG	R	CA				
	AB= Material ABS	LG= Light gray	AB= Material ABS	LG= Light gray	R= ROHS Conform	CA= Standard Export Carton				
	PC= Material Polycarbonat		PC= Material Polycarbonat	CL= Clear						

Enclosure Order Code
Part No.:
Customer:

DRW:	Jason	CHKD	Wilson	MATL:	Wilson	TOLERANCE	Mason	DATE	
APPD:	Schumi			FINISH	Jamy		Sheet No.		