

# EDCON-COMPONENTS



## SPECIFICATION:

Current Rating: 50mA / 12VDC  
 Insulator Resistance: 100M ohm bei 100VDC  
 Dielectric Withstanding: 250VAC for 1 min.  
 Operating Temperature: -30°C ~ +85°C  
 Contact Resistance: 500m Ohm max.  
 Travel: 0,20 / +-0,1mm

## Drawing

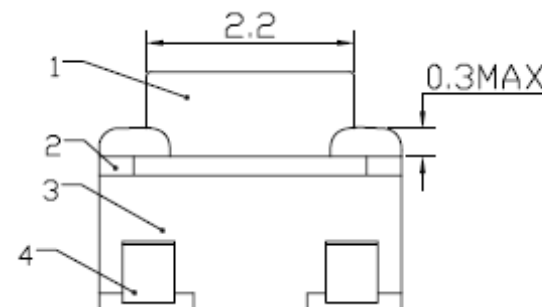
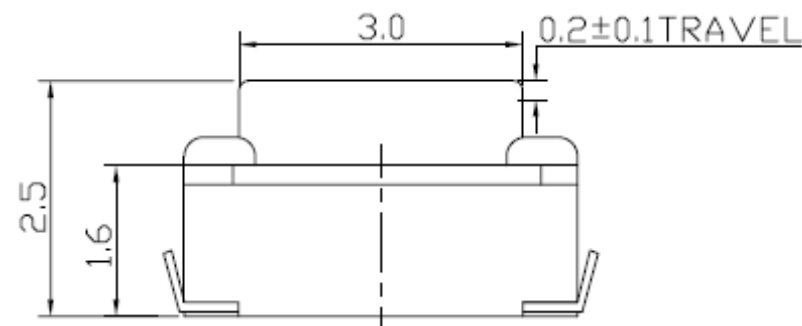
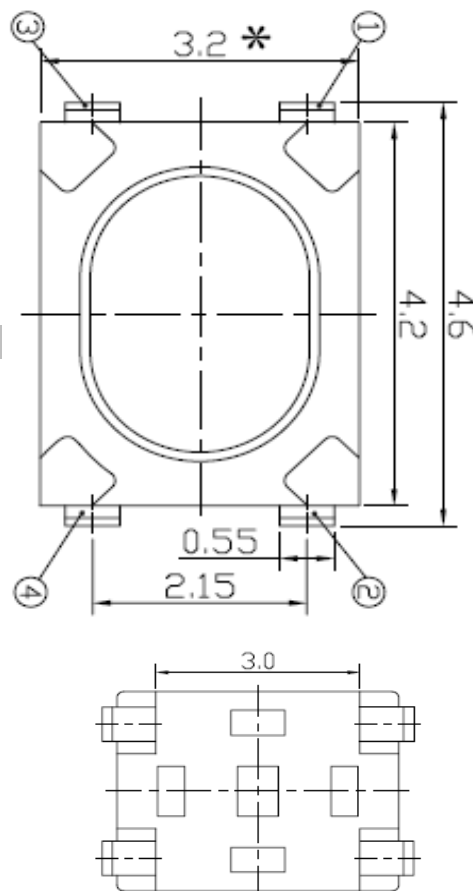

## P.C.B Layout

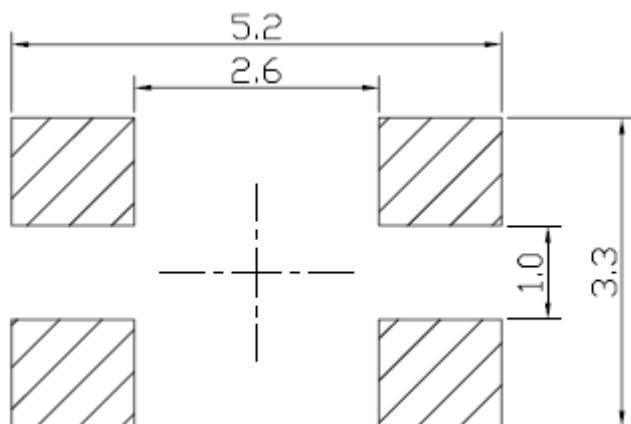

**Tact Switch 4,20 x 3,20mm**

Part No.: **Q12007**

Customer:

DRW:	Jason	CHKD	Wilson	MATL:	Wilson	TOLERANCE	Mason	DATE	16.02.2015
APPD:	Schumi			FINISH	Jamy		Sheet No.	1 from 3	

# EDCON-COMPONENTS



## Ordering Informations

Serie	Total height w. Body	Fill with 0	Operating Force	Polarisation Peg	Electrical life	Fill with 0	ROHS	Packing		
<b>Q12007</b>	<b>025</b>	<b>X</b>	<b>181</b>	<b>N</b>	<b>104</b>	<b>X</b>	<b>R</b>	<b>TRxxx</b>		

**025**= 2,5mm

<b>181</b> = 180gr	<b>N</b> = without Peg	<b>104</b> = 100000 Cycles
<b>251</b> = 250gr	<b>Y</b> = with Peg	
<b>401</b> = 400gr		

<b>N</b> = non ROHS	<b>BU</b> = Bulk Ware
<b>R</b> = ROHS conform	<b>TY</b> = Tray Packing
	<b>TR102</b> = Tape/Reel Packing 1000PCS

**Tact Switch 4,20 x 3,20mm**

Part No.: **Q12007**

DRW:	Jason	CHKD	Wilson	MATL:	Wilson	TOLERANCE	Mason	DATE	02.02.2008
APPD:	Schumi			FINISH	Jamy		Sheet No.		2 from 3

Customer:



## Soldering Profile for Lead Soldering

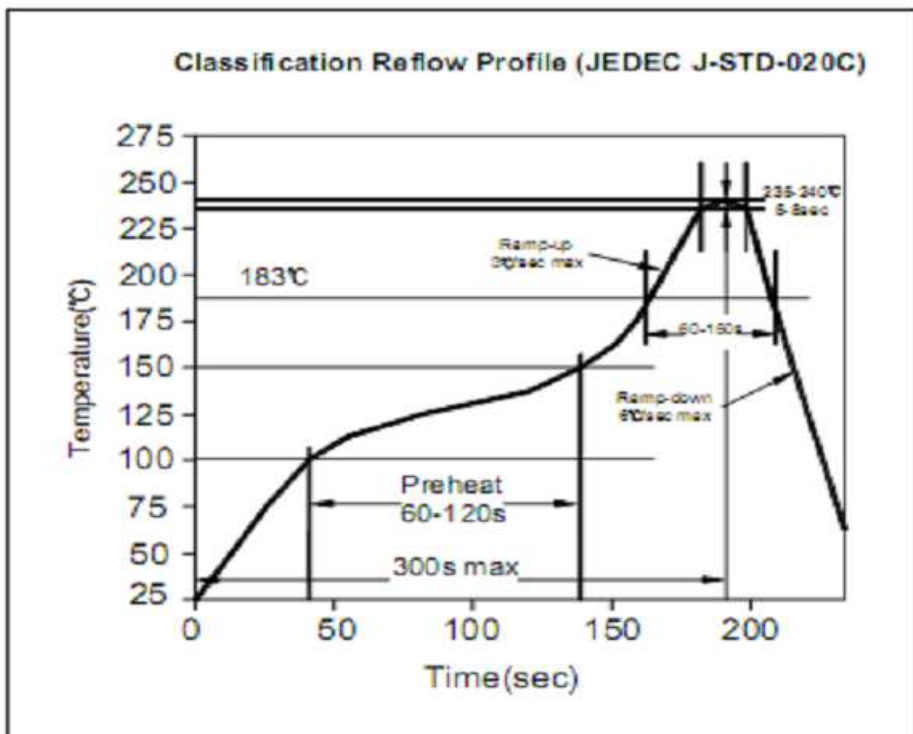

## Soldering Profile for Lead Free Soldering

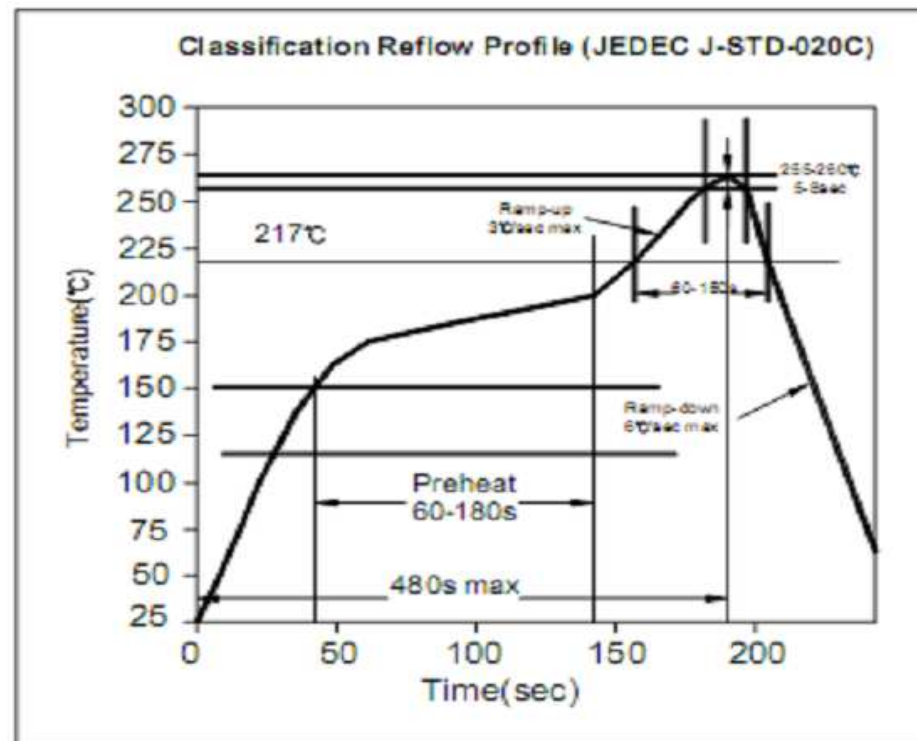

**Tact Switch 4,20 x 3,20mm**

Part No.: **Q12007**

DRW:	Jason	CHKD	Wilson	MATL:	Wilson	TOLERANCE	Mason	DATE	16.02.2015	Customer:
APPD:	Schumi			FINISH	Jamy		Sheet No.	3 from 3		