

# EDCON-COMPONENTS



## Technical Discription

High and stable operating voltage  
 Low self-discharge rate (less than 1% after 1 year storage at 25°C)  
 Operating Temperature ( -60°C ~ + 105°C)  
 Hermetecally glass-to-metal-sealing  
 Stainless steel container  
 Non-flammable electrolyte  
 Bobbin type  
 UL (MH46528), CE, SGS recognized  
 ISO9001:2008 approved  
 AIG Insurance

## Characteristics

Nominal capacity (1mA - 2.0V): 13000mAh  
 Nominal Voltage: 3,6V  
 Max. constant current: 200mA  
 Max. pulse current: 400mA  
 Weight: 102gr.  
 Volume: Ø 26,8x100mm  
 Workable temperature: . -60°C ~ + 105°C

## Warning Informations

Fire, explosion and sever burn hazard  
 Do not recharge, crush, disassemble, heat above 212°F (100°C), incinerate, short circuit of expose contents to water.  
 Do not reverse the positive and negative pole of battery while using it.  
 Do not solder directly on the battery.  
 Dispose of used batteries prombtly

## Applications

Utility meters (electricity meters, water meters, gas meters, AMR)  
 Security systems (door lockers, smoke alrams sensors, detectors)  
 CMOS memory and RTC backup  
 Vehicle tracking  
 Industrial clocks  
 Sea buoys , remote monitoring systems  
 Military electronics

**Lithium SOCI2 Battery Type  
 High Temperature**

Part No.: **B16026**

Customer:

DRW:	Jason	CHKD	Wilson	MATL:	Wilson	TOLERANCE	Mason	DATE	24.02.2017
APPD:	Schumi			FINISH	Jamy		Sheet No.		1 from 4

# EDCON-COMPONENTS



## Dimensions (mm)

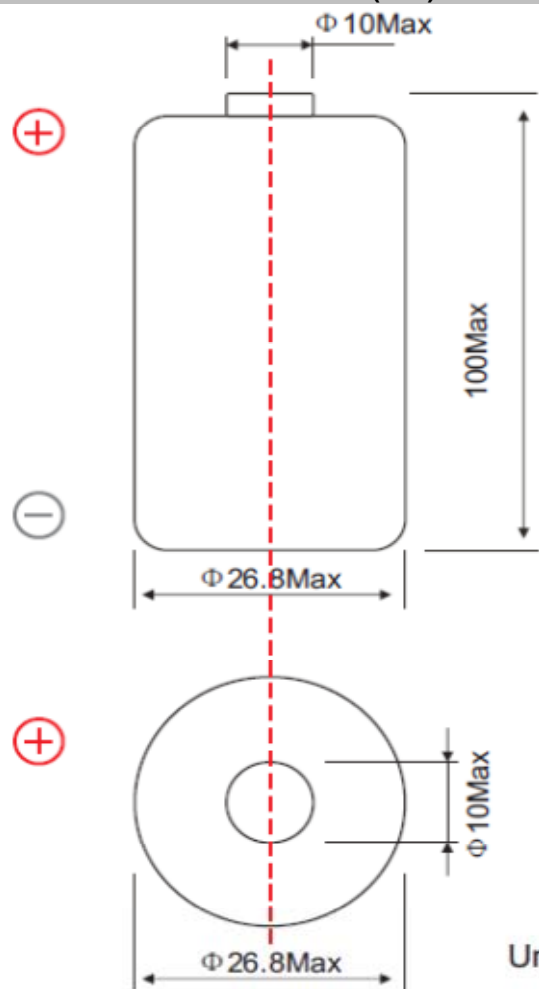

## Voltage vs temperature curve

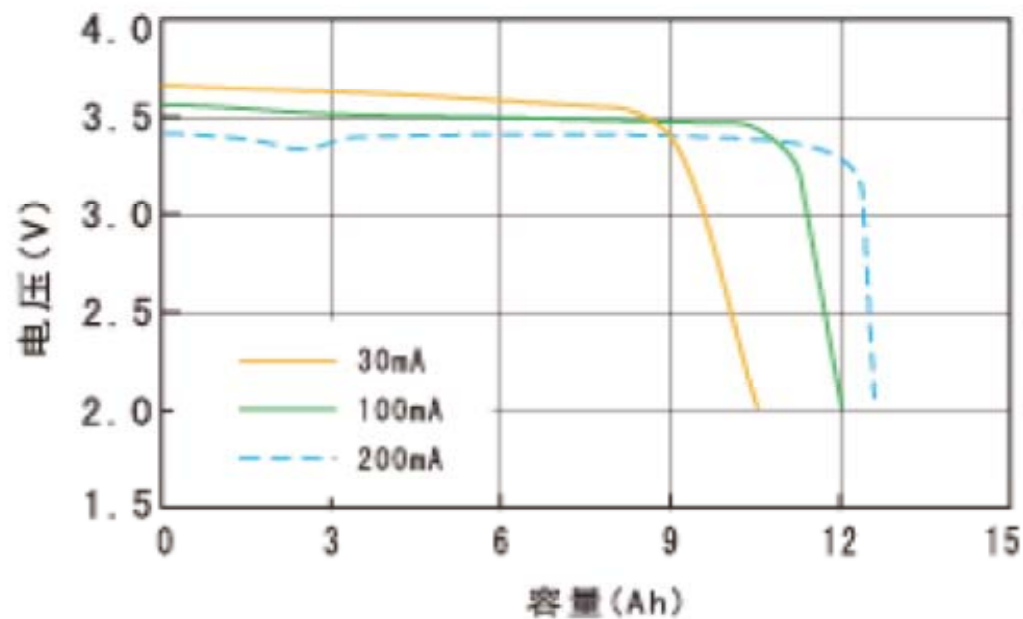

Lithium SOCl <sub>2</sub> Battery Type High Temperature	
Part No.:	<b>B16026</b>
Customer:	

DRW:	Jason	CHKD	Wilson	MATL:	Wilson	TOLERANCE	Mason	DATE	24.02.2017
APPD:	Schumi			FINISH	Jamy		Sheet No.	2 from 4	



Discharge Characteristics

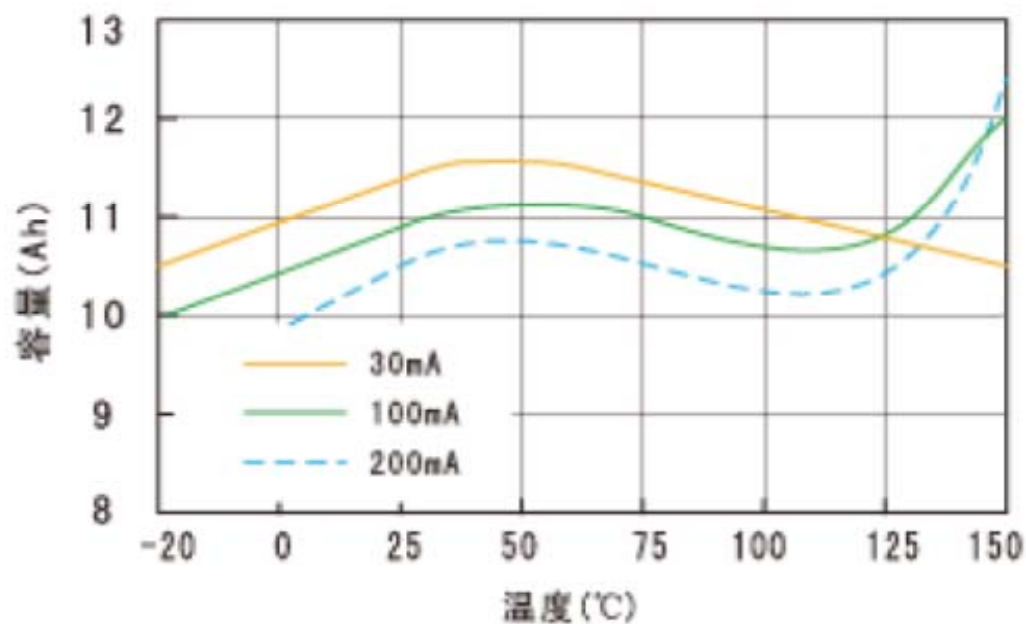

<b>Lithium SOCl<sub>2</sub> Battery Type High Temperature</b>	
Part No.:	<b>B16026</b>
Customer:	

DRW:	Jason	CHKD	Wilson	MATL:	Wilson	TOLERANCE	Mason	DATE	24.02.2017
APPD:	Schumi			FINISH	Jamy		Sheet No.	3 from 4	

# EDCON-COMPONENTS



## Ordering Informations

Serie	Type of Batery	Termination Option	ROHS	Packing	Customer No.	-	Customer type
B16026	ER26100S	X	R	T			

A= Axial Led Wire	R= ROHS Conform	T= Tray	When our customer need special item	Sequential number from our customer
P1= Radial Pin both side one round pin	N= NON ROHS Conform	I= individual		
P2= Radial Pin both side one flat pin				
P3= Radial Pin one side two pin other side one pin				
X= without any Termination				

<b>Lithium SOCl2 Battery Type High Temperature</b>
Part No.: <b>B16026</b>
Customer:

DRW:	Jason	CHKD	Wilson	MATL:	Wilson	TOLERANCE	Mason	DATE	24.02.2017
APPD:	Schumi			FINISH	Jamy		Sheet No.		4 from 4