

EDCON-COMPONENTS



Technical Discription

Parts	Material	Finish
Bolt	Steel	Nickel
Split Washer	Steel	Nickel
Washer	Steel	Nickel
Nut	Steel	Nickel

Drawing (mm)

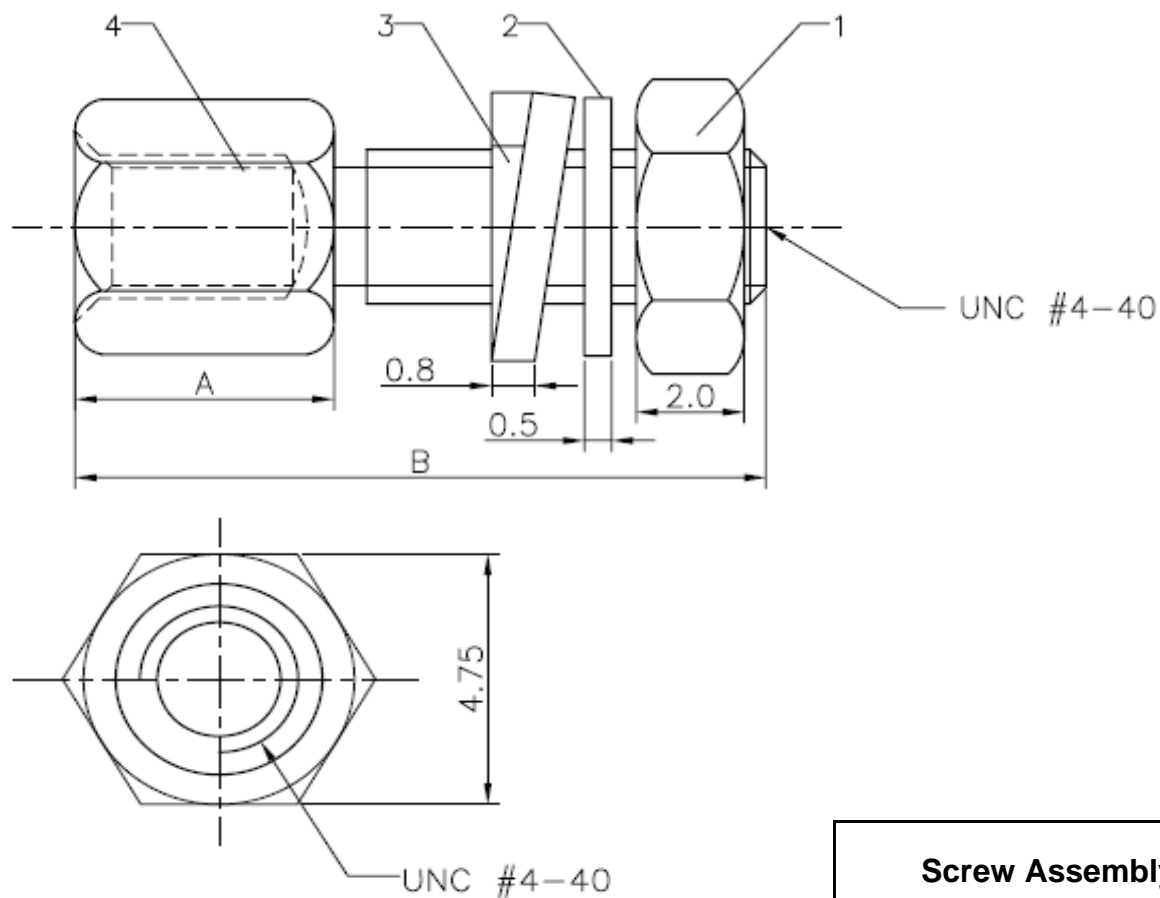

Screw Assembly
Part No.:
Customer:

DRW:	Jason	CHKD	Wilson	MATL:	Wilson	TOLERANCE	Mason	DATE	20.01.2011
APPD:	Schumi			FINISH	Jamy		Sheet No.	1 from 2	

EDCON-COMPONENTS



Ordering Informations

Terminal

Serie	Dim A	Dim B	Component Support	ROHS	Packing
-------	-------	-------	-------------------	------	---------

T24G600	A	A	4321	R	BU
---------	---	---	------	---	----

A= 4,80mm	A= 11,80mm	4321= included Component 1 , 2, 3, 4	R= ROHS Conform N= NON ROHS Conform	BU= Bulk Ware
B= 5,80mm	B= 12,00mm			
	C= 12,80mm	4320= included Component 2, 3, 4		
	D= 17,80mm			
	E= 15,70mm	4301= included Component 1, 3, 4		
	F= 18,80mm			
	G= 10,00mm	4021= included Component 1, 2, 4		
		4000= only Component 4		

Screw Assembly
Part No.: T24G600
Customer:

DRW:	Jason	CHKD	Wilson	MATL:	Wilson	TOLERANCE	Mason	DATE	20.01.2011
APPD:	Schumi			FINISH	Jamy		Sheet No.		2 from 2