

Technical Specification

Electrical Characteristics

Standard Resistance Range: 100Ω ~ 1,0MΩ
 Resistance Tolerance: +/-30% Standard
 Contact Resistance Variation : ≤3%
 Effective Travel: 215° normal
 Absolute Minimum Resistance: ≤ 1% max.
 Resistance: Essentially infinite:

Environmental Characteristics

Power Rating: (50VDC max.) 0,3W @ 70°C
 Temperature Range: -30°C to +100°C
 Temperature Coefficient: +/-250ppm/°C
 Power Rating: 0,3W @ 70°C
 Load Life: 1000hours, 0,3W @70°C

Features

THT/ Single-Turn/ Cermet / Industrial
 4 Terminals Styles

Physical Characteristics

Mechanical Angle: 240° +/- 10°
 Operating Torque: ≤30mN-m
 Marking: Resistance Resistance Code
 Standard Packing: 200PCS per Bag

Technical Dimensions Type 3306P

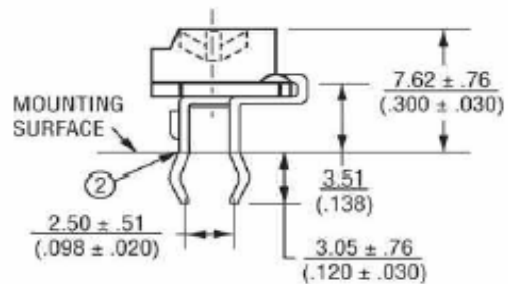
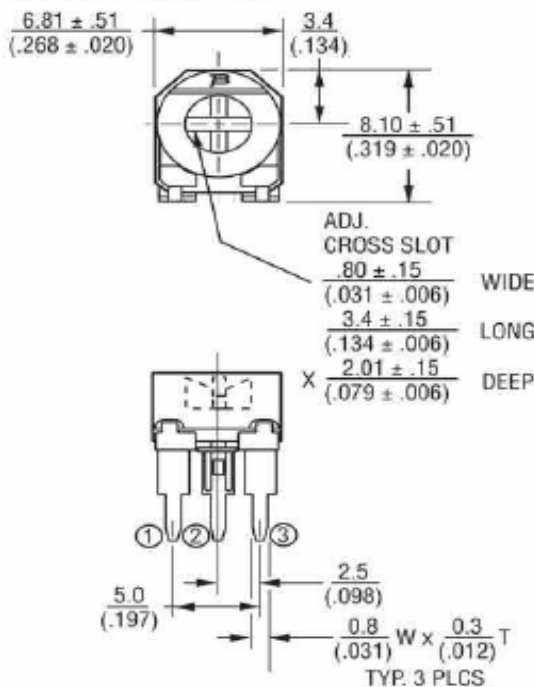

Physical Structure

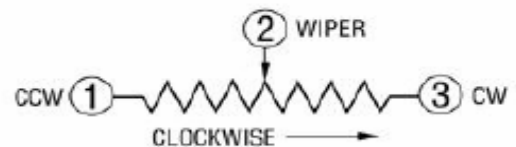

**8,1mm THT Single-Turn
 Trimmer Type 3306P**
X58005
 Customer:

DRW:	Jason	CHKD	Jules	MATL:	Wu	DATE	06.09.2009
APPD:	Join			FINISH	Shieh	Sheet	1 from 3

Copyright by EDCON-COMPONENTS H.Schmitt

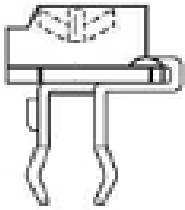

Range Code Table

PCB Layout

Ordering Code	Range
101	100Ω
201	200Ω
501	500Ω
102	1,0KΩ
202	2,0KΩ
502	5,0KΩ
103	10KΩ
203	20KΩ
503	50KΩ
104	100KΩ
204	200KΩ
504	500KΩ
105	1,0MΩ

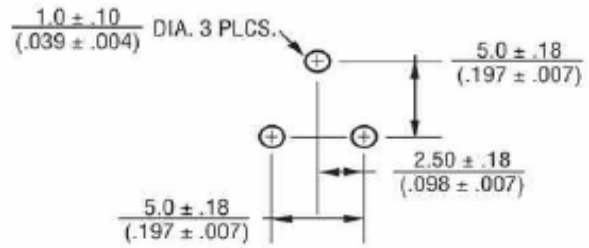

8,1mm THT Single-Turn Trimmer Type 3306P	
0	X58005
Customer:	
DRW:	Jason
APPD:	Join
CHKD:	Jules
MATL:	Wu
FINISH:	Shieh
DATE:	06.09.2009
Sheet:	2 from 3

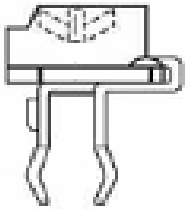

Soldering Profile

Classification Reflow Profile (JEDEC J-STD-020C)

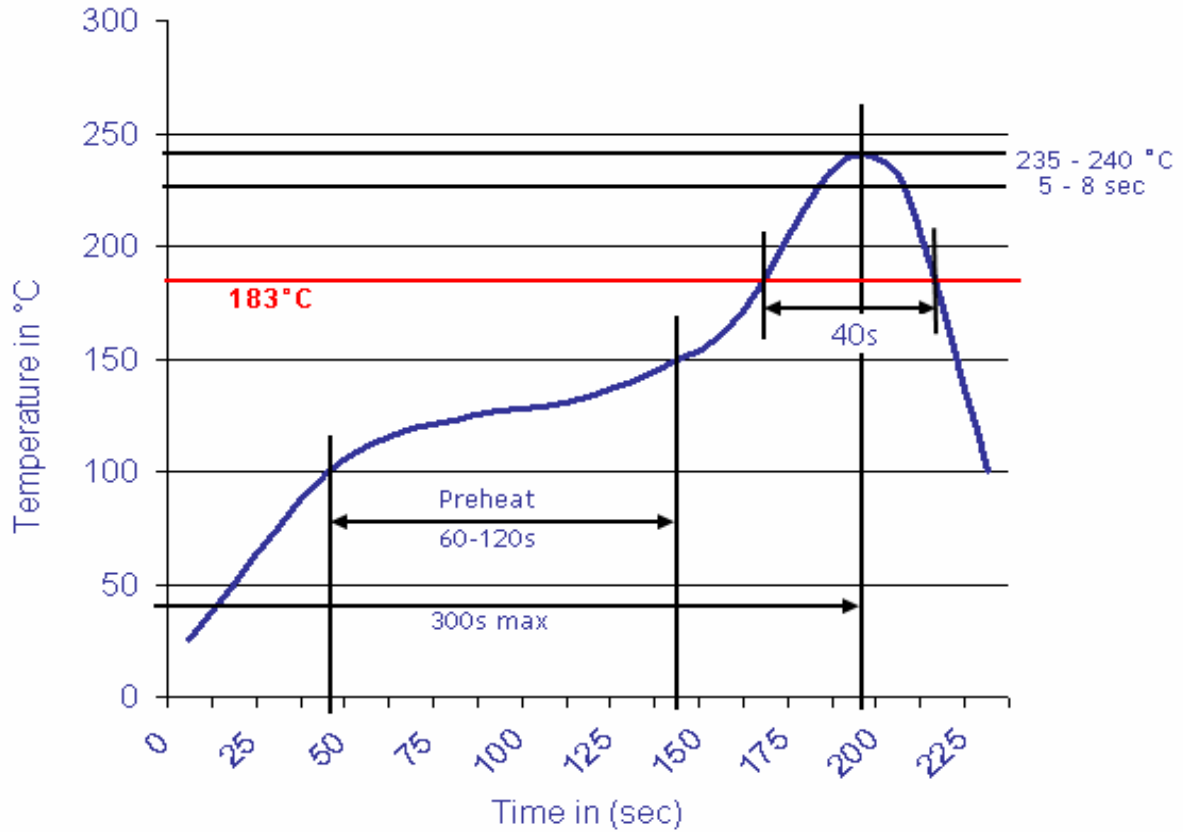

Ordering Information

Serie	Ordering Code	Tolerance	ROHS	Packing		
X58005	101	M	R	BU201		

101 = 100Ω	M = Tol. 20%	R = ROHS conform	BU201 = Bulk-Ware 200PCS
	K = Tol. 10%	N =NON ROHS conform	

8,1mm THT Single-Turn Trimmer Type 3306P	
0	X58005
Customer:	

DRW:	Jason	CHKD	Jules	MATL:	Wu	DATE	06.09.2009
APPD:	Join			FINISH	Shieh	Sheet	3 from 3