



DISCRIPTION

FEATURES

High Frequency Design
 Excellent Mechanical Strength
 Excellent Solderability
 High Reliability
 Low Profile

OPTIONS

Tape & Reel is Standard (Qty:2000 Pcs)
 Bulk Packing Available for smaller quantities
 Tolerance: J=5% and K=10% is Standard,
 Tighter Tolerances Available

APPLICATIONS

VCRs
 Video Cameras
 Communication System
 Automotive Systems
 Liquid Crystal Televisions
 Hard Disk Drives
 Network Systems

PHYSICAL CHARACTERISTICS

- IDC Max:Determined when superimposed
 Testing: (Equivalent acceptable) Inductance:HP4284A
- RDC:QuadTech 1880 Milliohmeter
- Operating temperature: -40°C to +105°C
- Storage Temperature: -40°C to +105°C
 Solder methods: Vapor Phase,Infrared Reflow
 Resistance to soldering heat:260°C for 10 seconds

ELECTRICAL SPECIFICATIONS

Properties	Test conditions		Value	Unit	Tol.
Inductance		L	1,0	mH	see Site 2
Q factor		Q	---		min.
DC-resistance		DCR typ.	---	mΩ	typ.
DC-resistance		DCR max.	0,82	mΩ	max.
Self-Res. Freq.		SRF	---	KHz	min.
Test-Freq.			1	KHz	
Rated Current		IDC	0,5	A	max.
Saturation Current		I SAT	---	A	max.

1. This electronic component is meant to be used in general electronic equipment. Before the incorporation of this component into any equipment with higher and more reliable requirements such as aviation, aerospace, submarine, nuclear control, transportation, transportation signal, disaster prevention, medical, public information network, etc. or if there is a possibility of injuries or damages to the human body, Edcon –Components must be informed before the stage of design-in. Evaluation checks for safety have to be performed on each electronic components used in electrical circuits that require high safety and reliability functions.

SMT TOROIDAL COMMON MODE CHOKES

Part No.: **S39029-102**

Customer:

DRW:	Chang	CHKD	Young	MATL:	Chu Chi	DATE	25.06.2009
APPD:	Pong			FINISH	Vienna	Sheet	1 from 2



TECHNICAL INFORMATIONS

Dimensions (mm)

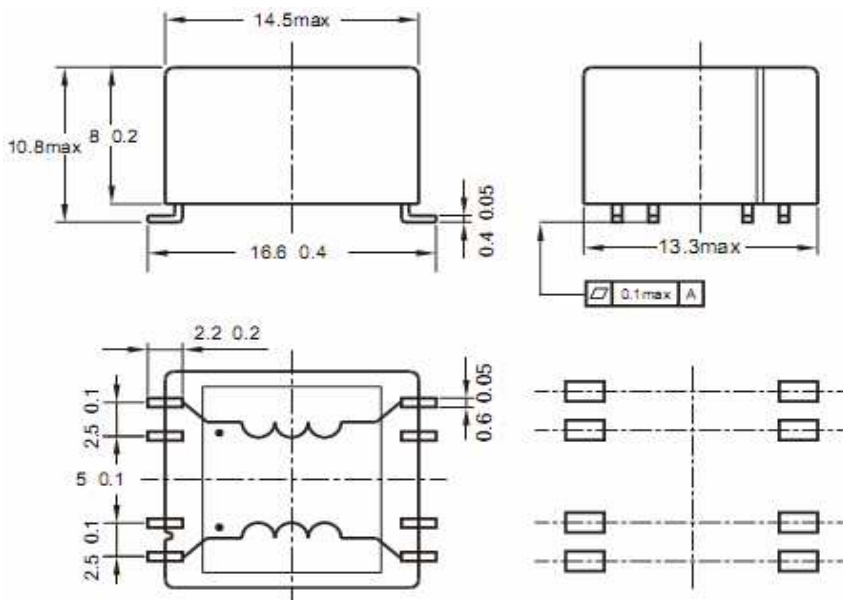

Ordering Information

Serie and Range	Tolerance	ROHS	Packing
S39029-102	J	R	TR
	J = 5%	R = ROHS	BU = Bulk Ware
	K = 10%	N = non ROHS	TR = Tape Reel
	Y = 15%		

**Soldering Profile for Lead Free Soldering
 255-260°C**

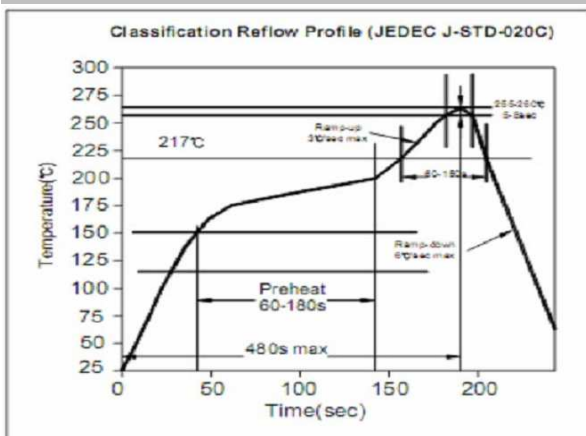

**Soldering Profile for Lead Free Soldering
 235-240°C**

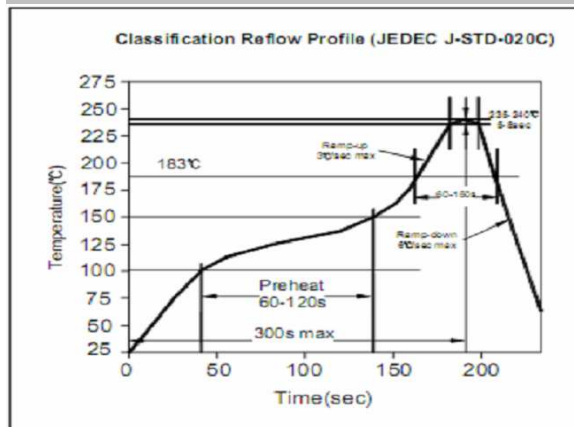

1. This electronic component is meant to be used in general electronic equipment. Before the incorporation of this component into any equipment with higher and more reliable requirements such as aviation, aerospace, submarine, nuclear control, transportation, transportation signal, disaster prevention, medical, public information network, etc. or if there is a possibility of injuries or damages to the human body, Edcon -Components must be informed before the stage of design-in. Evaluation checks for safety have to be performed on each electronic components used in electrical circuits that require high safety and reliability functions.

**SMT TOROIDAL
 COMMON MODE
 CHOKES**

Part No.: **S39029-102**

Customer:

DRW:	Chang	CHKD	Young	MATL:	Chu Chi	DATE	25.06.2009
APPD:	Pong			FINISH	Vienna	Sheet	2 from 2