

## DISCRIPTION

### FEATURES

Magnetically Shielded Structure  
 Low DC Resistance  
 Excellent Mechanical Strength  
 High Reliability and Excellent Solderability  
 Low and square Profile  
 High heat resistance

### OPTIONS

Tape & Reel is Standard ( Qty : 2000 pcs )  
 Bulk Packing Available for smaller quantities  
 Tolerance: M=20% ; N=30% is Standard,  
 Tighter Tolerances Available

### APPLICATIONS

VCRs, Notebook, DC/DC Converters  
 Video Digital Cameras  
 Communication System  
 Automotive System Power supplier  
 LCD PDP Televisions  
 Hard Disk Drives, Topset, XDSL  
 Computer Peripheral Equipment

## PHYSICAL CHARACTERISTICS

- Inductor Testing : HP4284A ( Equivalent acceptable )  
 DCR : QuadTech 1880 mΩ Q-HP4342A - SRF- HP4191A  
 IDCMax current is decreased 10% against its initial value
- Operating temperature : -40°C ~ +105°C
- Storage temperature : -40°C ~ +105°C
- Solder methods : Vapor Phase, Infrared Reflow
- Resistance to soldering heat : 260°C for 10 seconds

## ELECTRICAL SPECIFICATIONS

Properties	Test conditions		Value	Unit	Tol.
Inductance		<b>L</b>	22	μH	see Site 2
Q factor		<b>Q</b>	---		min.
DC-resistance		<b>DCR typ.</b>	---	Ω	typ.
DC-resistance		<b>DCR max.</b>	1,00	Ω	max.
Self-Res. Freq.		<b>SRF</b>	---	KHz	min.
Test-Freq.			100	KHz	
Rated Current		<b>IDC</b>	0,25	A	max.
Saturation Current		<b>I SAT</b>	---	A	max.

1. This electronic component is meant to be used in general electronic equipment. Before the incorporation of this component into any equipment with higher and more reliable requirements such as aviation, aerospace, submarine, nuclear control, transportation, transportation signal, disaster prevention, medical, public information network, etc. or if there is a possibility of injuries or damages to the human body, Edcon –Components must be informed before the stage of design-in. Evaluation checks for safety have to be performed on each electronic components used in electrical circuits that require high safety and reliability functions.

### MAGNETIC SHIELDED SMT POWER INDUCTOR

Part No.: **S26001-220**

Customer:

DRW:	Chang	CHKD	Young	MATL:	Chu Chi	DATE	18.06.2009
APPD:	Pong			FINISH	Vienna	Sheet	1 from 2

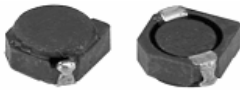

## TECHNICAL INFORMATIONS

### Dimensions ( mm )

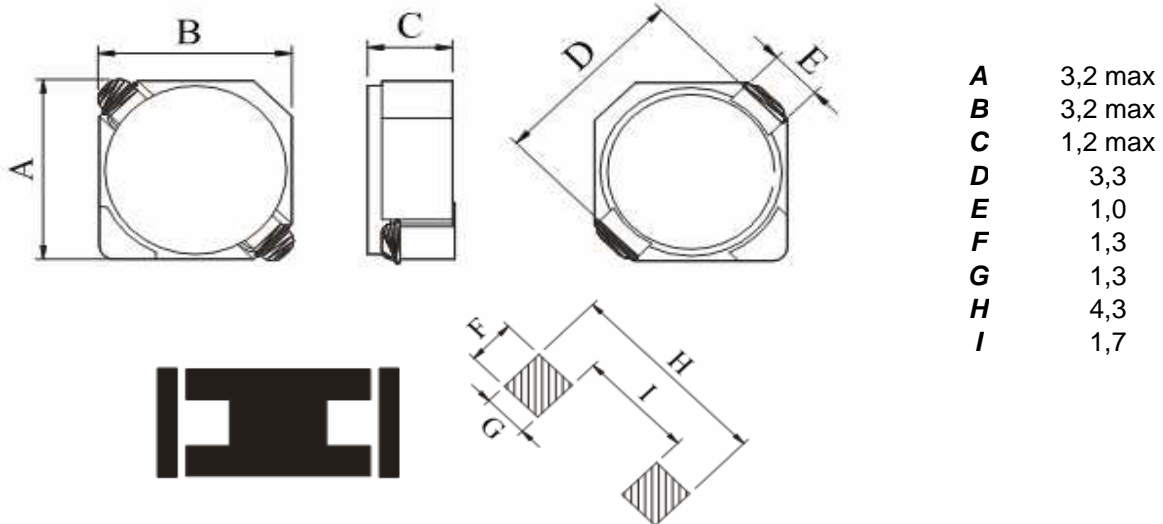

### Ordering Information

Serie and Range	Tolerance	ROHS	Packing
<b>S26001-220</b>	<b>M</b>	<b>R</b>	<b>TR</b>
	<b>K = 10%</b>	<b>R = ROHS</b>	<b>BU = Bulk Ware</b>
	<b>M = 20%</b>	<b>N = non ROHS</b>	<b>TR = Tape Reel</b>
	<b>N = 30%</b>		

### Soldering Profile for Lead Free Soldering 235-240°C

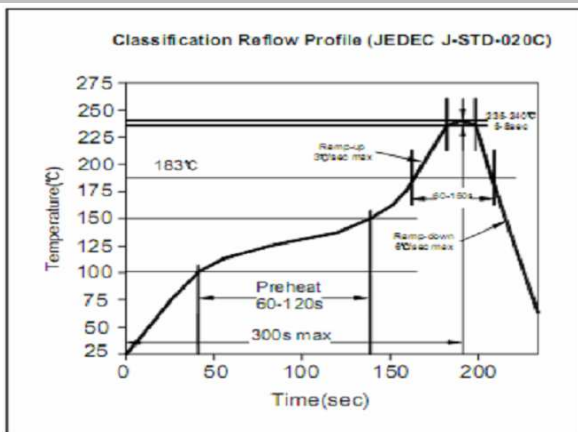

### Soldering Profile for Lead Free Soldering 255-260°C

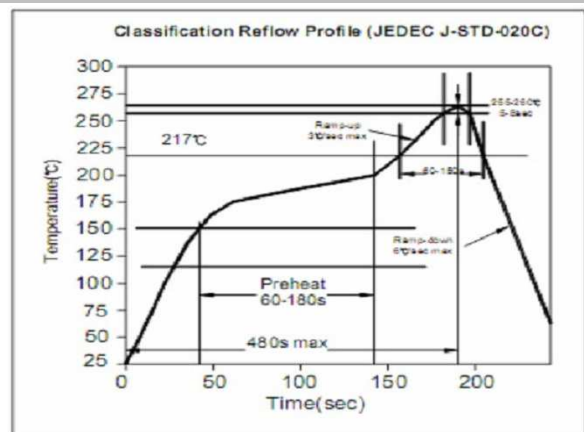

1. This electronic component is meant to be used in general electronic equipment. Before the incorporation of this component into any equipment with higher and more reliable requirements such as aviation, aerospace, submarine, nuclear control, transportation, transportation signal, disaster prevention, medical, public information network, etc. or if there is a possibility of injuries or damages to the human body, Edcon -Components must be informed before the stage of design-in. Evaluation checks for safety have to be performed on each electronic components used in electrical circuits that require high safety and reliability functions.

### MAGNETIC SHIELDED SMT POWER INDUCTOR

Part No.: **S26001-220**

Customer:

DRW:	Chang	CHKD	Young	MATL:	Chu Chi	DATE	18.06.2009
APPD:	Pong			FINISH	Vienna	Sheet	2 from 2