



**DISCRIPTION**

**FEATURES**

High Frequency desgin  
 Heat Resistant Molded Resin  
 Excellent Mechanical Strength  
 Excellent Solderability  
 Low Profile, Low coast  
 Low DCR

**OPTIONS**

Tape & Reel is Standard ( Qty : 2000 pcs. )  
 Bulk Packing Available for smaller quantites  
 Tolerance: K = 10% ; M=20% is Standard,  
 Tighter Tolerances Available

**APPLICATIONS**

Power supply for VTRs  
 OA equipment  
 LCD televisions  
 Notebook PCs  
 Portable communication equipment  
 DC / DC converters

**PHYSICAL CHARACTERISTICS**

- Test Frequenz with HP4284A ( equivalent acceptable )  
 RDC : QuardTech 1880 Milliohmeter - Q - HP4342A - SRF - HP4191A
- IDC Max : Determined when superimposed DC current is decreased 10% against its initial value
- Operating Temperature : -40°C ~ +105°C
- Storage Temperature : -40°C ~ +105°C
- Soldering Methods : Vapor Phase, Infrared Reflow
- Resistance to soldering heat : 260°C for 10 seconds
- Solvent resistance : Conforms to MIL-STD-202E

**ELECTRICAL SPECIFICATIONS**

Properties	Test conditions		Value	Unit	Tol.
Inductance		<b>L</b>	220	µH	see Site 2
Q factor		<b>Q</b>	35		min.
DC-resistance		<b>DCR typ.</b>	---	Ω	typ.
DC-resistance		<b>DCR max.</b>	1,10	Ω	max.
Self-Res. Freq.		<b>SRF</b>	---	kHz	min.
Test-Freq.			100	kHz	
Rated Current		<b>IDC</b>	22	mA	max.
Saturation Current		<b>Isat</b>	---	mA	typ.

1. This electronic component is meant to be used in general electronic equipment. Before the incorporation of this component into any equipment with higher and more reliable requirements such as aviation, aerospace, submarine, nuclear control, transportation, transportation signal, disaster prevention, medical, public information network, etc. or if there is a possibility of injuries or damages to the human body, Edcon –Components must be informed before the stage of design-in. Evaluation checks for safety have to be performed on each electronic components used in electrical circuits that require high safety and reliability functions.

**SMT POWER WOUND  
 CHIP INDUCTOR**

Part No.: **S20002-221**

Customer:

DRW:	Chang	CHKD	Young	MATL:	Chu Chi	DATE	16.06.2009
APPD:	Pong			FINISH	Vienna	Sheet	1 from 2



**TECHNICAL INFORMATIONS**

**Dimensions ( mm )**

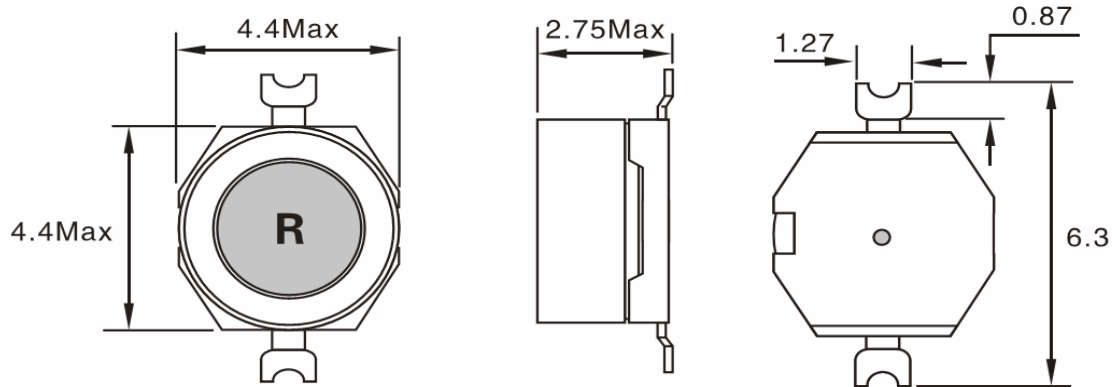

**Ordering Information**

Serie and Range	Tolerance	ROHS	Packing
S20002-221	M	R	TR
	K = 10%	R = ROHS	BU = Bulk Ware
	M = 20%	N = non ROHS	TR = Tape Reel
	N = 30%		

**Soldering Profile for Lead Free Soldering  
235-240°C**

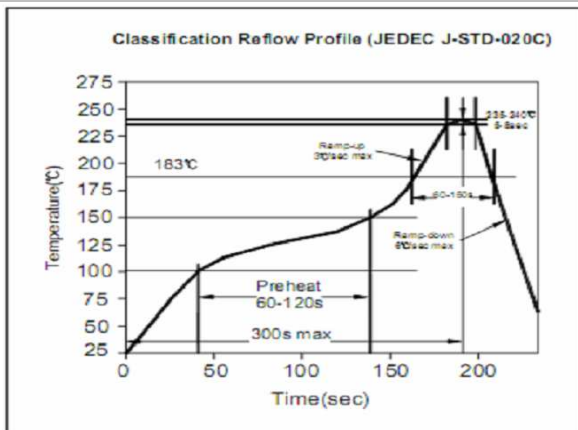

**Soldering Profile for Lead Free Soldering  
255-260°C**



1. This electronic component is meant to be used in general electronic equipment. Before the incorporation of this component into any equipment with higher and more reliable requirements such as aviation, aerospace, submarine, nuclear control, transportation, transportation signal, disaster prevention, medical, public information network, etc. or if there is a possibility of injuries or damages to the human body, Edcon -Components must be informed before the stage of design-in. Evaluation checks for safety have to be performed on each electronic components used in electrical circuits that require high safety and reliability functions.

**SMT POWER WOUND  
CHIP INDUCTOR**

Part No.: **S20002-221**

Customer:

DRW:	Chang	CHKD	Young	MATL:	Chu Chi	DATE	16.06.2009
APPD:	Pong			FINISH	Vienna	Sheet	2 from 2