



DISCRIPTION

FEATURES

High Frequency desgin
 Heat Resistant Molded Resin
 Excellent Mechanical Strength
 Excellent Solderability
 Low Profile, Low coast
 Low DCR

OPTIONS

Tape & Reel is Standard (Qty : 2000 pcs.)
 Bulk Packing Available for smaller quantites
 Tolerance: K = 10% ; M=20% is Standard,
 Tighter Tolerances Available

APPLICATIONS

Power supply for VTRs
 OA equipment
 LCD televisions
 Notebook PCs
 Portable communication equipment
 DC / DC converters

PHYSICAL CHARACTERISTICS

- Test Frequenz with HP4284A (equivalent acceptable)
 RDC : QuardTech 1880 Milliohmeter - Q - HP4342A - SRF - HP4191A
- IDC Max : Determined when superimposed DC current is decreased 10% against its initial value
- Operating Temperature : -40°C ~ +105°C
- Storage Temperature : -40°C ~ +105°C
- Soldering Methods : Vapor Phase, Infrared Reflow
- Resistance to soldering heat : 260°C for 10 seconds
- Solvent resistance : Conforms to MIL-STD-202E

ELECTRICAL SPECIFICATIONS

Properties	Test conditions		Value	Unit	Tol.
Inductance		L	1,5	mH	see Site 2
Q factor		Q	35		min.
DC-resistance		DCR typ.	---	Ω	typ.
DC-resistance		DCR max.	5,30	Ω	max.
Self-Res. Freq.		SRF	---	kHz	min.
Test-Freq.			100	kHz	
Rated Current		IDC	8	mA	max.
Saturation Current		Isat	---	mA	typ.

1. This electronic component is meant to be used in general electronic equipment. Before the incorporation of this component into any equipment with higher and more reliable requirements such as aviation, aerospace, submarine, nuclear control, transportation, transportation signal, disaster prevention, medical, public information network, etc. or if there is a possibility of injuries or damages to the human body, Edcon –Components must be informed before the stage of design-in. Evaluation checks for safety have to be performed on each electronic components used in electrical circuits that require high safety and reliability functions.

**SMT POWER WOUND
 CHIP INDUCTOR**

Part No.: **S20002-152**

Customer:

DRW:	Chang	CHKD	Young	MATL:	Chu Chi	DATE	16.06.2009
APPD:	Pong			FINISH	Vienna	Sheet	1 from 2



TECHNICAL INFORMATIONS

Dimensions (mm)

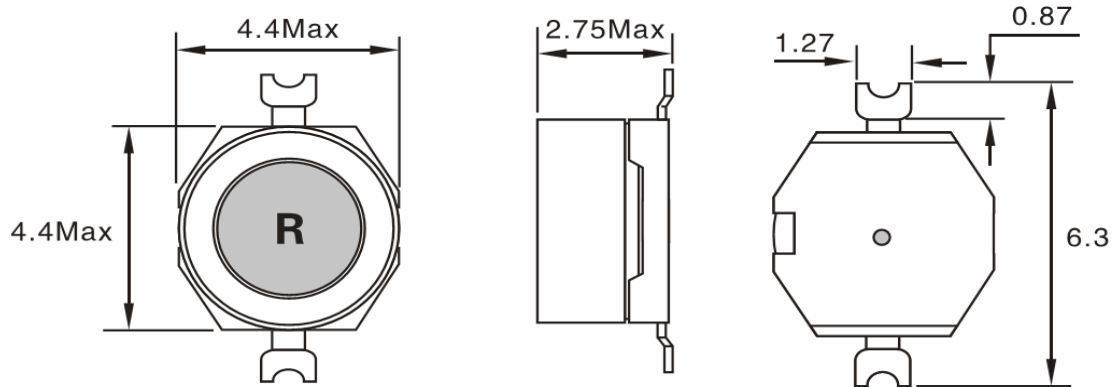

Ordering Information

Serie and Range	Tolerance	ROHS	Packing
S20002-152	M	R	TR
	K = 10%	R = ROHS	BU = Bulk Ware
	M = 20%	N = non ROHS	TR = Tape Reel
	N = 30%		

Soldering Profile for Lead Free Soldering 235-240°C

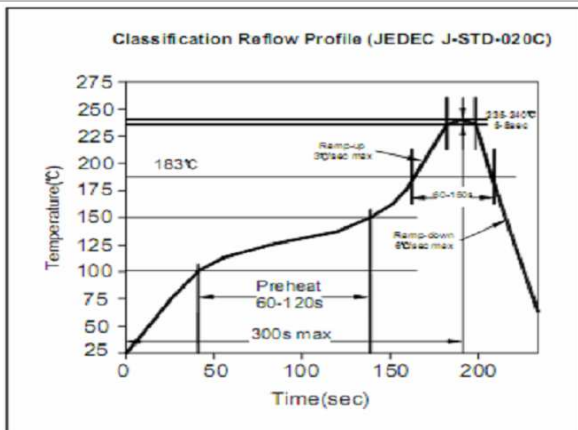

Soldering Profile for Lead Free Soldering 255-260°C



1. This electronic component is meant to be used in general electronic equipment. Before the incorporation of this component into any equipment with higher and more reliable requirements such as aviation, aerospace, submarine, nuclear control, transportation, transportation signal, disaster prevention, medical, public information network, etc. or if there is a possibility of injuries or damages to the human body, Edcon -Components must be informed before the stage of design-in. Evaluation checks for safety have to be performed on each electronic components used in electrical circuits that require high safety and reliability functions.

SMT POWER WOUND CHIP INDUCTOR

Part No.: **S20002-152**

Customer:

DRW:	Chang	CHKD	Young	MATL:	Chu Chi	DATE	16.06.2009
APPD:	Pong			FINISH	Vienna	Sheet	2 from 2