

**NOTE:**

- SOLDERTAIL TO BE WITHIN 0.05 UPWARD AND 0.2 DOWNWARD FROM Z-DATUM PLACE, AND COPLANALITY OF SOLDERTAILS TO BE WITHIN 0.10. MEASUREMENT POINT IS  $\triangle C$  SOLDERTAILS TIP.
- INSPECTION SYMBOL:  
: MANUFACTURER INSPECTION  
: Q.C INSPECTION
- ACCORDING HSF CONCRAFT LEVEL1

				GENERAL TOLERANCE		DRAW: WES	PART NO: 0710A0BA92B
				X. ±0.30	X.° ±2.00°	CHECKED:	TITLE: MINI PCI EXPRESS ASSEMBLY
				.X ±0.20	.X° ±1.00°		
C E080287A Andrew 09/12/2008				.XX ±0.10	.XX° ±0.50°	APPROVE: SEGA	DRAWING NO: 0710A0BA92B
B E080111A Roy 04/25/2008				.XXX ±0.05	.XXX° ±0.10°		
REV.	ECO NO.	DRAW	DATE	UNITS: mm	SHEET: 1/2		
MATERIAL:		FINISH:	DATE: 11/03/2005	 <b>CONCRAFT</b> DRAGONSTATE TECHNOLOGY CO., LTD			
A		B	C				

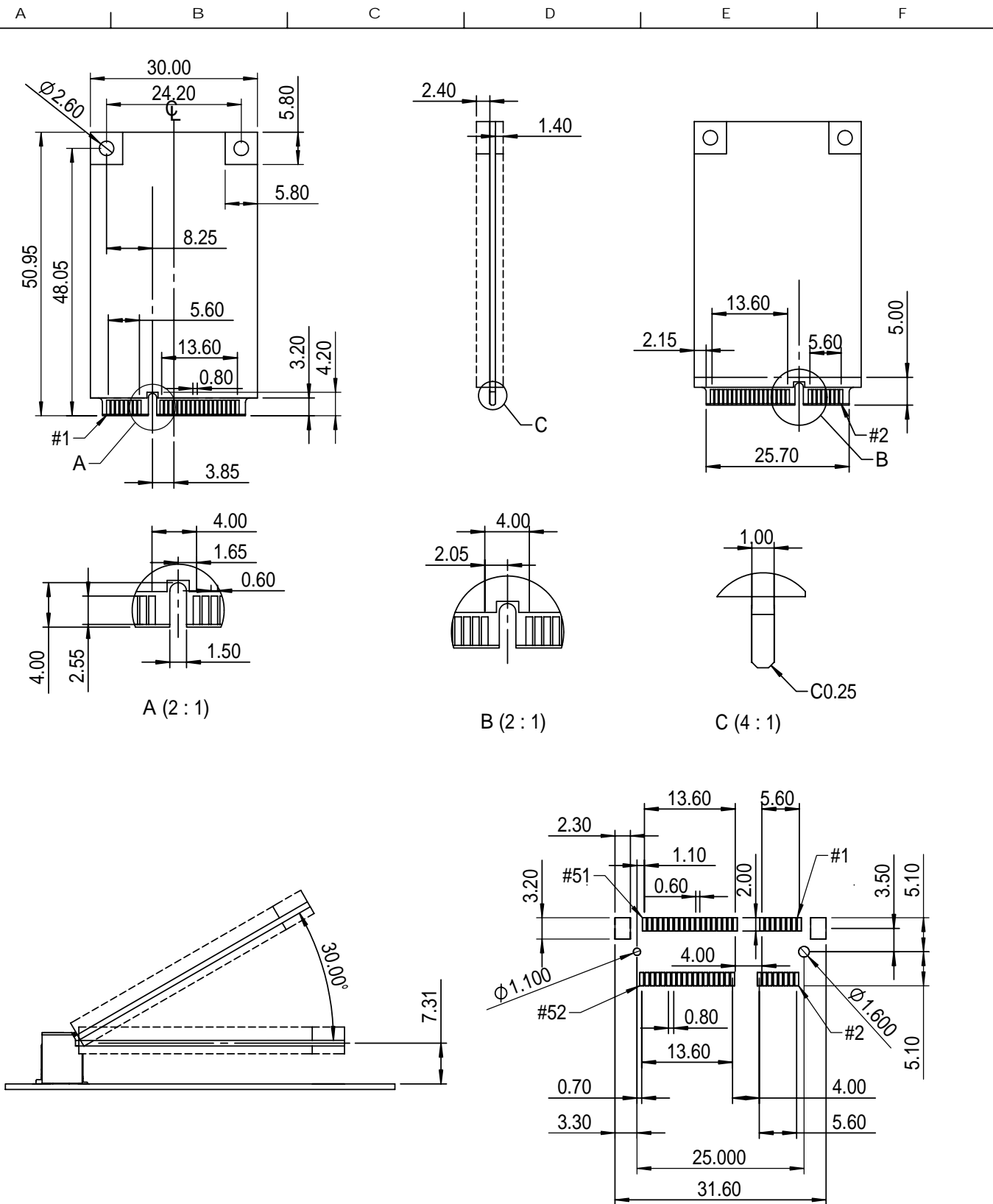

PCB LAYOUT

				GENERAL TOLERANCE		DRAW: WES	PART NO: 0710A0BA92B
				X. ±0.30	X.° ±2.00°	CHECKED:	TITLE: MINI PCI EXPRESS ASSEMBLY
				.X ±0.20	.X.° ±1.00°	APPROVE: SEGA	DRAWING NO: 0710A0BA92B
C	E080287A	Andrew	09/12/2008	.XX ±0.10	.XX.° ±0.50°		
B	E080111A	Roy	04/25/2008	.XXX ±0.05	.XXX.° ±0.10°		
REV.	ECO NO.	DRAW	DATE	UNITS: mm	SHEET: 2 / 2		
MATERIAL:		FINISH:	DATE: 11 / 03 / 2005	 <b>CONCRAFT</b> DRAGONSTATE TECHNOLOGY CO., LTD			
A		B	C				