

**NOTE:**

1. SOLDER TAIL TO BE WITHIN 0.05 UPWARD AND 0.2 DOWNWARD FROM Z-DATUM PLACE, AND COPLANALITY OF SOLDER TAILS TO BE WITHIN 0.10. MEASUREMENT POINT IS SOLDER TAILS TIP.
2. ACCORDING HSF CONCRRAFT LEVEL 1
3. INSPECTION SYMBOL:  
 : MANUFACTURER INSPECTION  
 : Q.C INSPECTION

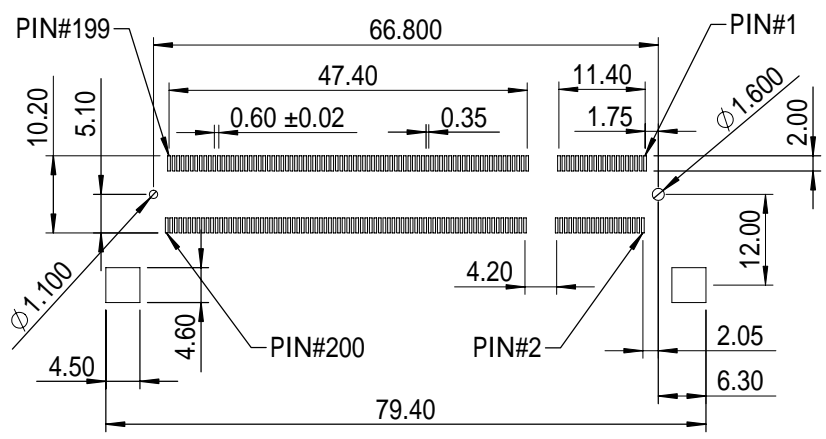

PCB LAYOUT : COMPONENT SIDE

				GENERAL TOLERANCE		DRAW: Roy	PART NO: 0701A1BE92E	
				X. ±0.30	X.° ± 2.00°	CHECKED:	TITLE: DDR S.O. DIMM 200P ASSEMBLY	
				.X ±0.20	.X° ± 1.00°		APPROVE: SEGA	DRAWING NO: 0701A1BE92E
				.XX ±0.10	.XX° ± 0.50°			
B	E080230A	Roy	08/05/2008	UNITS: mm	SHEET: 1/3			
REV.	ECO NO.	DRAW	DATE					
MATERIAL:		FINISH:	DATE: 03/17/2008	REV. A				

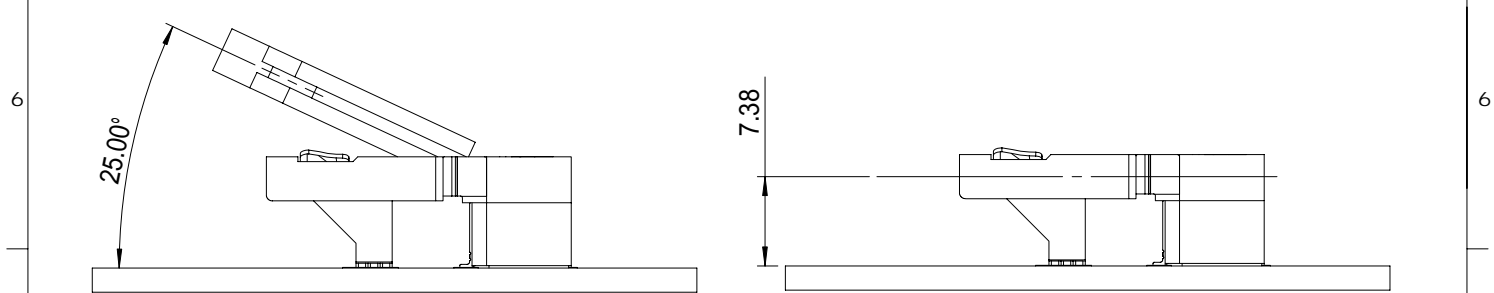
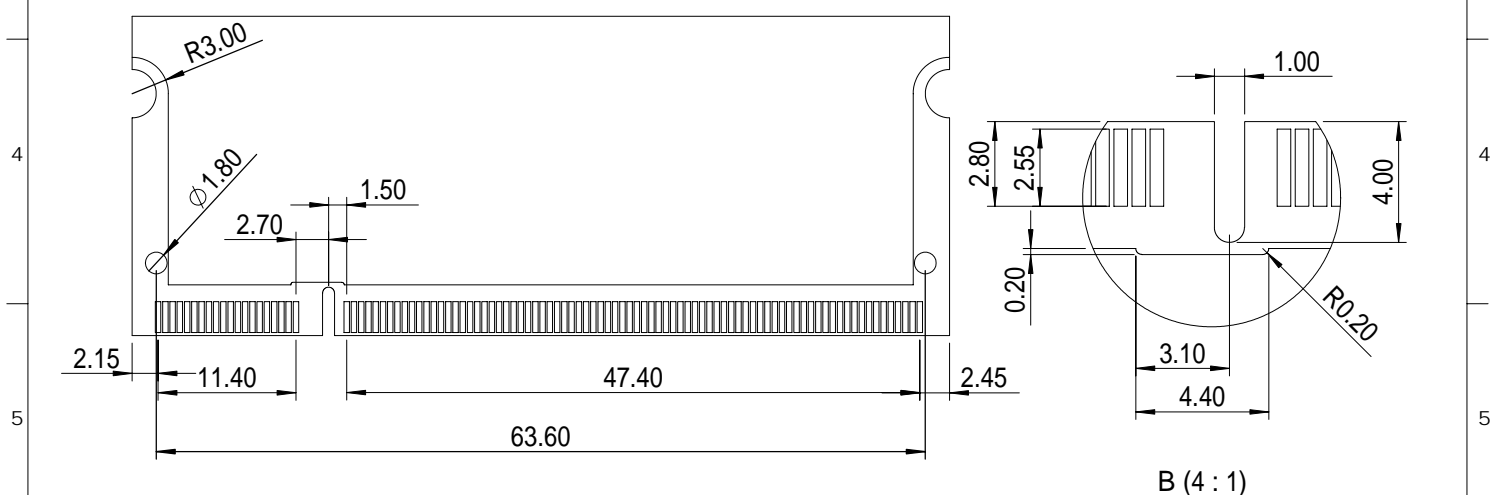
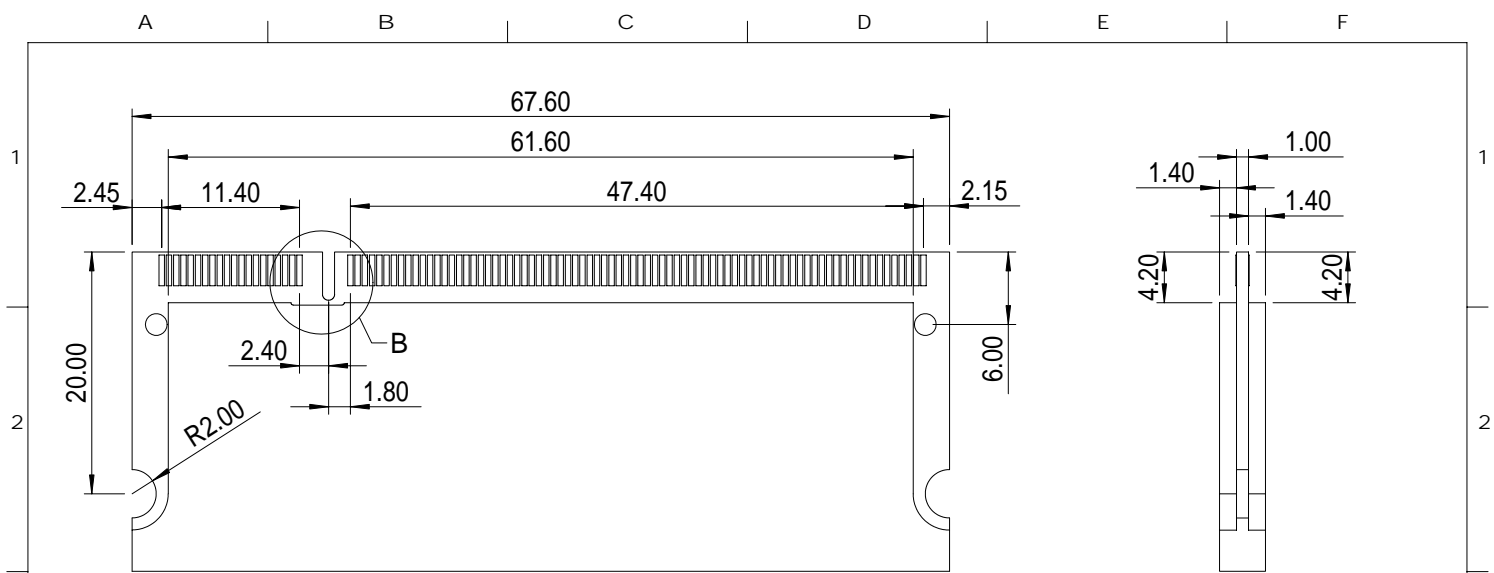

				GENERAL TOLERANCE		DRAW:	PART NO:
				X. ±0.30	X.° ± 2.00°	Roy	0701A1BE92E
				.X ±0.20	.X.° ± 1.00°	CHECKED:	TITLE:
				.XX ±0.10	.XX.° ± 0.50°		DDR S.O. DIMM 200P ASSEMBLY
				.XXX ±0.05		APPROVE:	DRAWING NO:
8	B	E080230A	Roy	08/05/2008	UNITS: mm	SEGA	0701A1BE92E
	REV.	ECO NO.	DRAW	DATE	⊕	 <b>CONCRAFT</b> DRAGONSTATE TECHNOLOGY CO., LTD	
	MATERIAL:	FINISH:	DATE:	03 / 17 / 2008	REV. A		

