

NOTE:
 1. SOLDER TAIL TO BE WITHIN 0.05 UPWARD AND 0.2 DOWNWARD FROM Z-DATUM PLACE, AND COPLANALITY OF SOLDER TAILS TO BE WITHIN 0.10. MEASUREMENT POINT IS SOLDER TAILS TIP.
 2. ACCORDING HSF CONCRRAFT LEVEL 1
 3. INSPECTION SYMBOL:
 : MANUFACTURER INSPECTION
 : Q.C INSPECTION

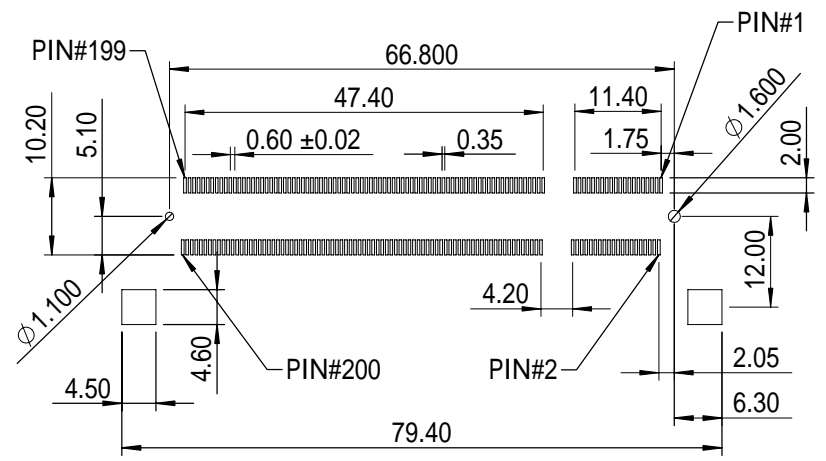

				GENERAL TOLERANCE		DRAW: Roy	PART NO: 0703A1BE92E	
				X. ±0.30	X.° ± 2.00°	CHECKED:	TITLE: DDR S.O. DIMM 200P ASSEMBLY	
				.X ±0.20	.X° ± 1.00°		APPROVE: SEGA	DRAWING NO: 0703A1BE92E
				.XX ±0.10	.XX° ± 0.50°			
8	B	E080230A	Roy	08/06/2008	UNITS: mm	SHEET: 1/3		
REV.	ECO NO.	DRAW	DATE					
MATERIAL:		FINISH:	DATE: 03/14/2008	REV. A	 CONCRRAFT DRAGONSTATE TECHNOLOGY CO., LTD			
A	B	C	D	E				F

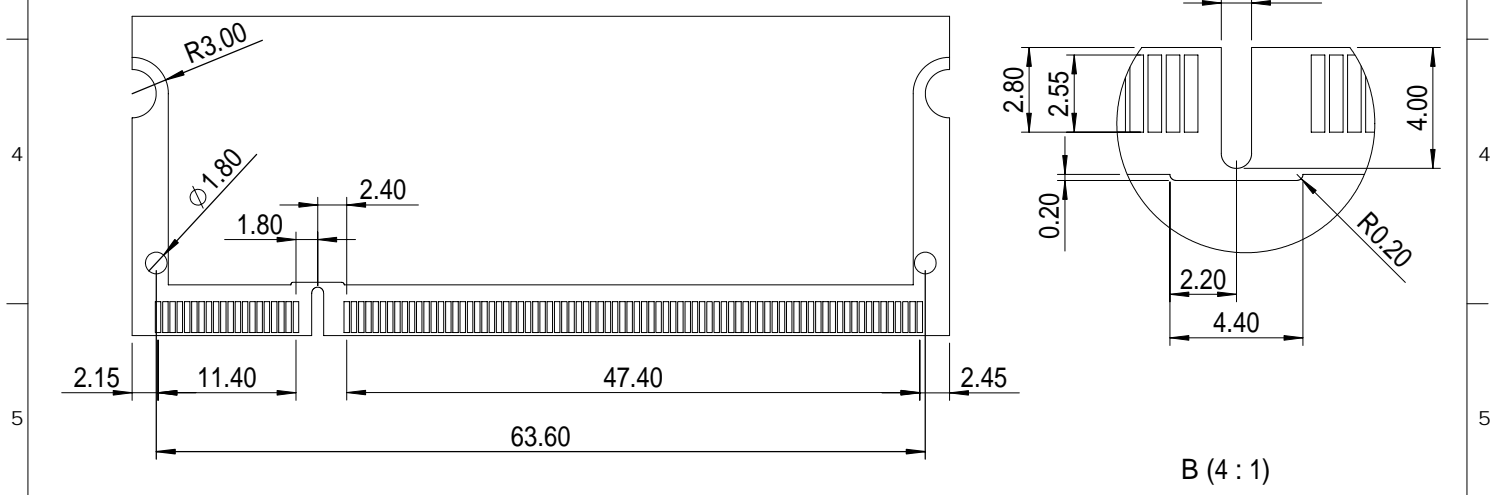
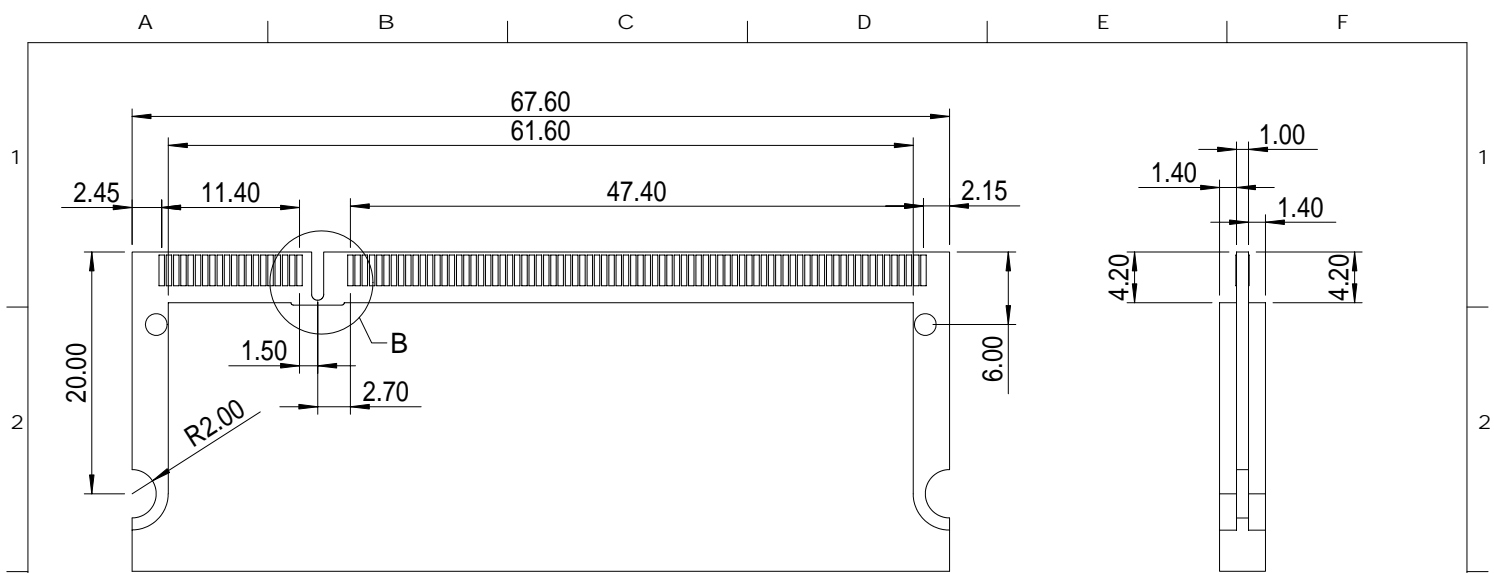

B (4 : 1)

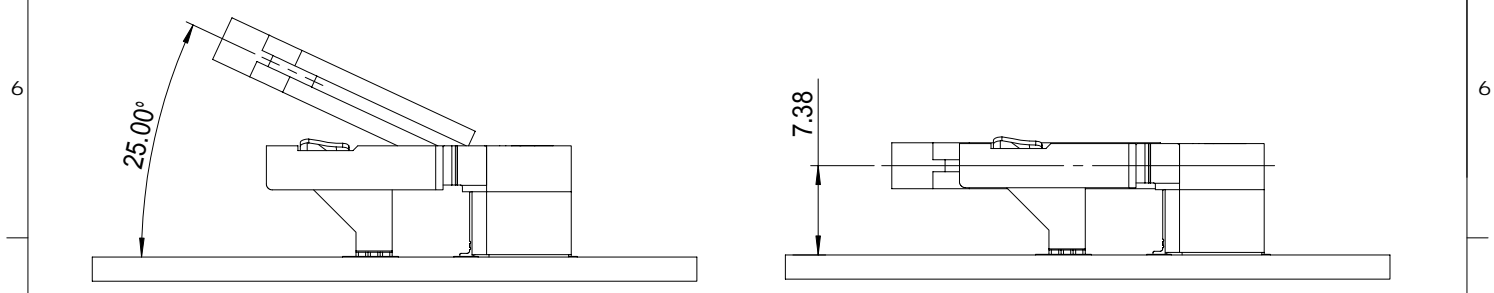

				GENERAL TOLERANCE		DRAW: Roy	PART NO: 0703A1BE92E
				X. ±0.30	X.° ± 2.00°	CHECKED:	TITLE: DDR S.O. DIMM 200P ASSEMBLY
				.X ±0.20	.X.° ± 1.00°		
				.XX ±0.10	.XX.° ± 0.50°	APPROVE: SEGA	DRAWING NO: 0703A1BE92E
				.XXX ±0.05			
B	E080230A	Roy	08/06/2008	UNITS: mm	SHEET: 2 / 3		
REV.	ECO NO.	DRAW	DATE			 CONCRAFT DRAGONSTATE TECHNOLOGY CO., LTD	
MATERIAL:	FINISH:	DATE:	REV. A				
A	B	C	03 / 14 / 2008	D	E	F	

DDR S.O. DIMM 200P 5.2&9.2 OVERLAY FIGURE

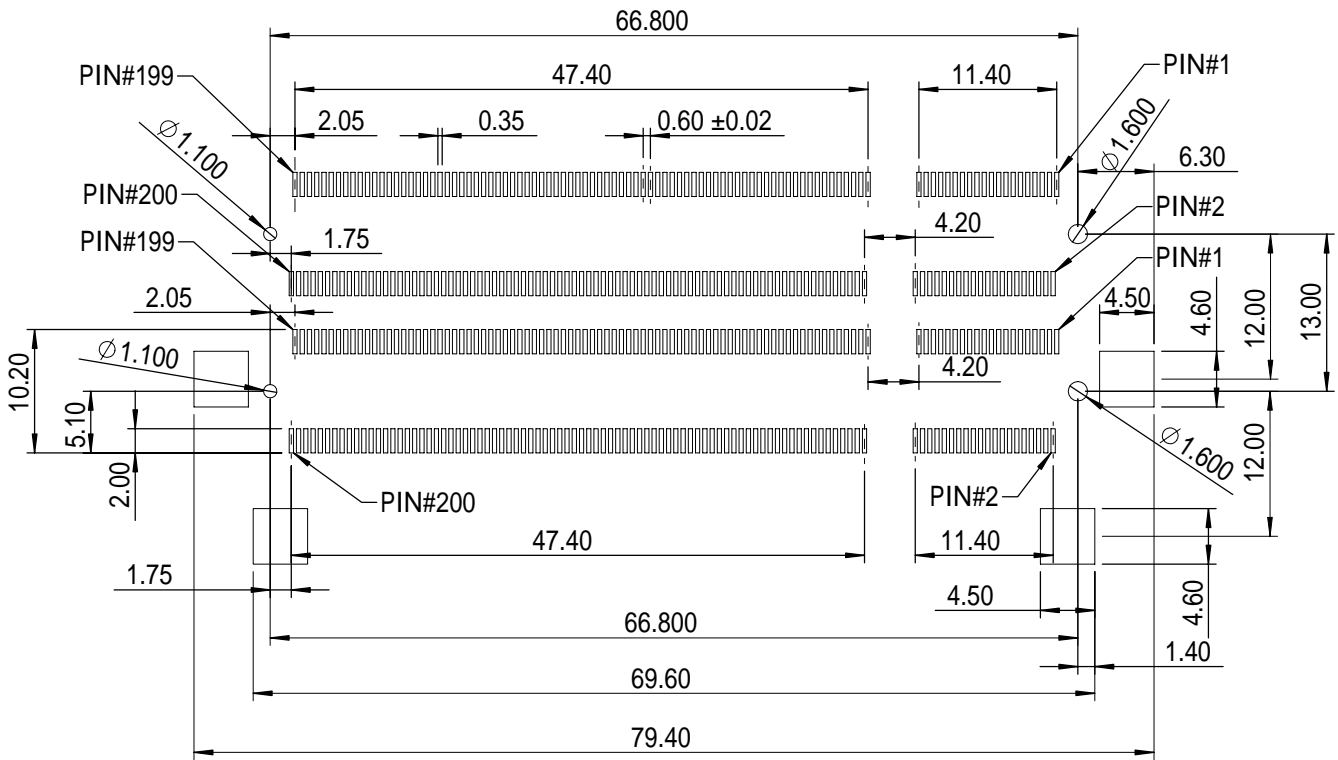
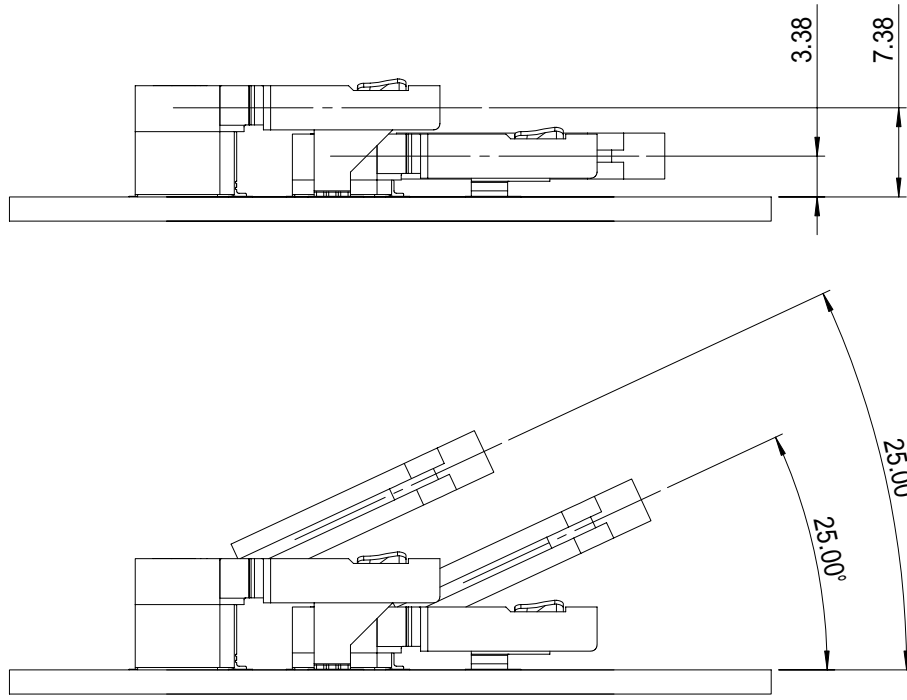

PCB LAYOUT : COMPONENT SIDE(5.2&9.2 TYPE)

				GENERAL TOLERANCE		DRAW:	PART NO:
				X. ±0.30	X.° ± 2.00°	Roy	0703A1BE92E
				.X ±0.20	.X° ± 1.00°	CHECKED:	TITLE:
				.XX ±0.10	.XX° ± 0.50°		DDR S.O. DIMM 200P ASSEMBLY
				.XXX ±0.05		APPROVE:	DRAWING NO:
B	E080230A	Roy	08/06/2008	UNITS: mm	SHEET: 3 / 3	SEGA	0703A1BE92E
REV.	ECO NO.	DRAW	DATE			 CONCRAFT DRAGONSTATE TECHNOLOGY CO., LTD	
MATERIAL:		FINISH:	DATE: 03 / 14 / 2008	REV. A			