

EDCON-COMPONENTS

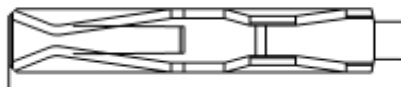

Specifications

- Voltage Rating:
- Current Rating
- Operating Temperature
- Contact Resistance
- Withstanding Voltage
- Insulation Resistance
- Applicable Wire
- Applicable P.C.B
- Applicable FPC/FFC
- Solder Height
- Crimp Tensile Strength

Drawing (dimensions all into mm)

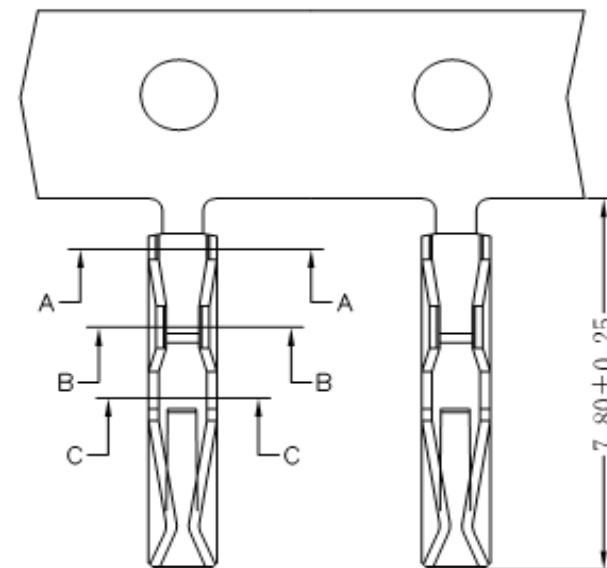
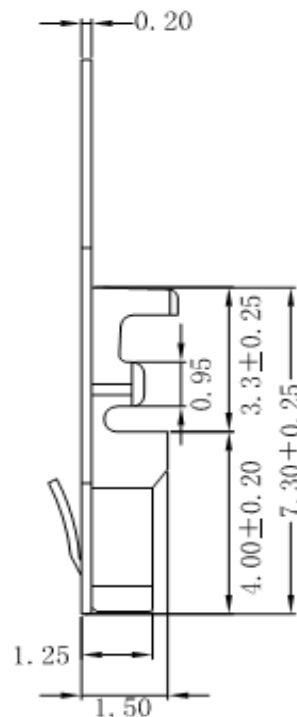
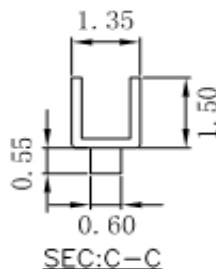
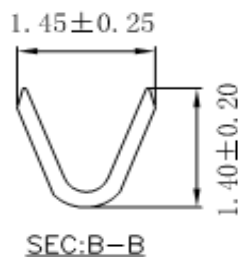
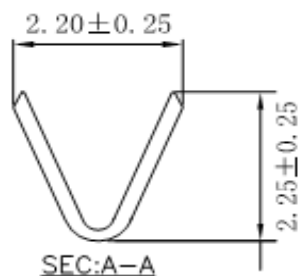

Terminal to Housing Serie xxxxxx
Pitch 2,00mm

Part No.: **T68T1017**

Customer:

DRW:	Jason	CHKD	Wilson	MATL:	Wilson	TOLERANCE	Mason	DATE	02.04.2009
APPD:	Schumi			FINISH	Jamy		Sheet No.	1 from 2	

www.edcon-components.com

email: info@edcon-components.com

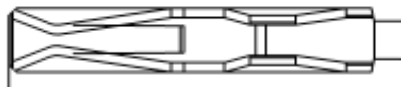

Ordering Informations

Serie	AWG-Wire	Contact Plating	Packing						
-------	----------	-----------------	---------	--	--	--	--	--	--

T68T1017	24	T	TR103						
-----------------	-----------	----------	--------------	--	--	--	--	--	--

24= AWG xx ~ xx	T= Tin Plated	TR103 = Tape /Reel 10000PCS							
	G= Gold Flash Plated								



Terminal to Housing Serie xxxxxx Pitch 2,00mm	
Part No.:	T68T1017
Customer:	

DRW:	Jason	CHKD	Wilson	MATL:	Wilson	TOLERANCE	Mason	DATE	02.04.2009
APPD:	Schumi			FINISH	Jamy		Sheet No.		2 from 2