

EDCON-COMPONENTS



Specifications

Rated Voltage:	5Vp-p max. square wave
Operating Voltage:	4~7Vp-p max. duty square wave
Rated Current:	40mA at 1,5Vo-p square wave 1/2 duty square wave 2731Hz
Coil Resistance:	42Ω +/-4Ω
Typical Sound Output:	85B min
Operating Frequency:	2731Hz +/-500Hz
Operating Temperature:	. -25°C to +70°C
Storage Temperature:	. -30°C to +85°C
Weight	1,5gr.
Life Test	Operate the part at 5Vp-p in room temperature continuously for 1000hours
Operating Temperature	Driving from -20°to +70°C withi n 30minutes for 2 cycles
High Temperature:	. +80 +/-2°C for 96hours
Low Temperature:	. -30 +/-2°C for 96hours
Humidity:	25°C +/-2°C, 90-95%RH, 5hr>up 55°C +/-2°C, 90-95% R H, 0,5hr>55°C +/-2°C, 90-95%RH, 5hr>down to 25°C+/-2°C 90-95%RH, 0,5hr, 10 cycles
Thermal Shock:	. -30°C +/-2°C, 30min>+20°C 15min> +80° C +/-2°C 30min> +20°C, 15min 5cycles
Shock	980/s² shock for each 3 mutually perpendicular directions to each of times by half sine wave
Vibration	1,5mm with 10 to 50Hz of vibration frequency to each of 3 perpendicular directions for 2hrs.
Drop Test	Dropped naturally from 700mm height onto the surface of 10mm thick wooden board. 2 directions upper and side of the part are to be applied

manufacture under normal operations.

Features

Flame Retardant Plastic

Applications

Automatic Control Equipment
Communication Equipment
Electronic Instruments

Warranty

All specifications must be satisfied after the test (Recovery: 2 to 4 hrs of recovery under the standard condition after the removal from test chamber). 90% min soldering pads shall be with solder (except the edge of pad).

THT Magnetic Transducer

Part No.: **I20025**

Customer:

DRW:	Jason	CHKD	Wilson	MATL:	Wilson	TOLERANCE	Mason	DATE	10.06.2010
APPD:	Schumi			FINISH	Jamy		Sheet No.		1 from 4

www.edcon-components.com

email: info@edcon-components.com

EDCON-COMPONENTS



Dimensions (mm)

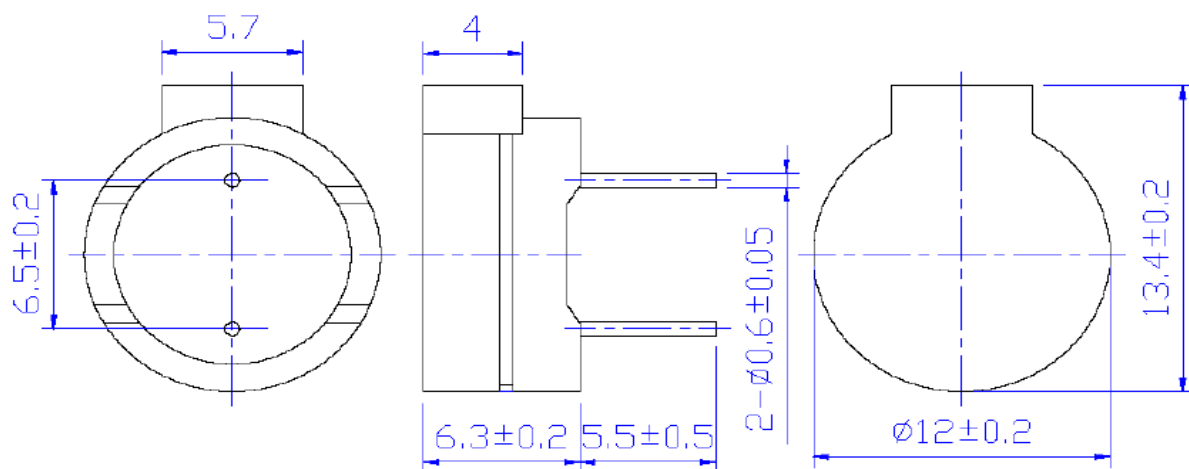

Characteristics

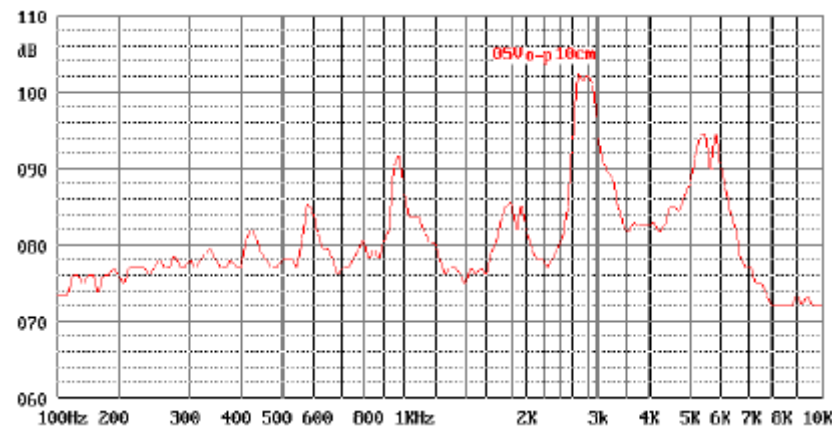

THT Magnetic Transducer

Part No.: **I20025**

DRW:	Jason	CHKD	Wilson	MATL:	Wilson	TOLERANCE	Mason	DATE	10.06.2010
APPD:	Schumi			FINISH	Jamy		Sheet No.	2 from 4	

Customer:

www.edcon-components.com

email: info@edcon-components.com

EDCON-COMPONENTS



Ordering Informations

Serie	Model-No.	ROHS	Package						
I20025	12E05422.7	R	TY						

R = ROHS Conform	TY = Tray Packing
N = NON ROHS Conform	TU = Tube Packing

THT Magnetic Tranducer	
Part No.:	I20025
Customer:	

DRW:	Jason	CHKD	Wilson	MATL:	Wilson	TOLERANCE	Mason	DATE	10.06.2010
APPD:	Schumi			FINISH	Jamy		Sheet No.		3 from 4



Soldering Profile Curve

Classification Reflow Profile (JEDEC J-STD-020C)

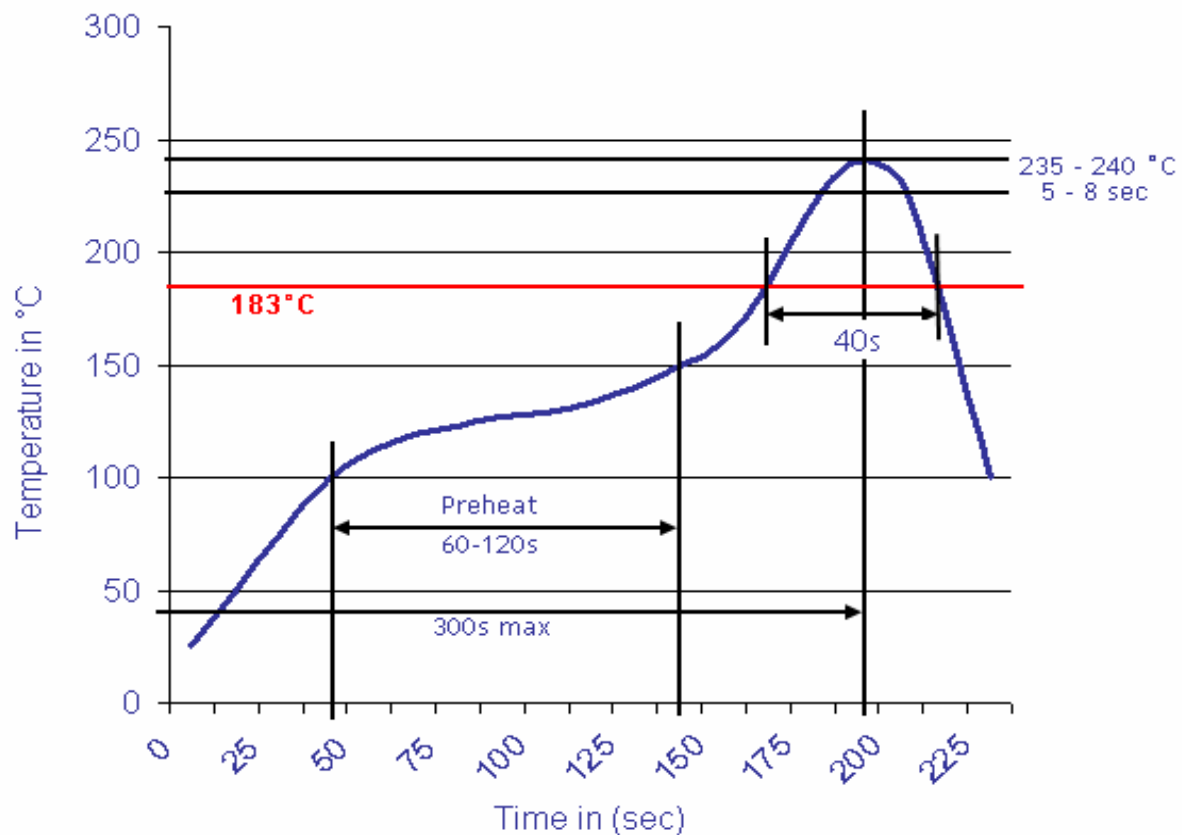

THT Magnetic Transducer

Part No.: **I20025**

DRW:	Jason	CHKD	Wilson	MATL:	Wilson	TOLERANCE	Mason	DATE	10.06.2010	Customer:
APPD:	Schumi			FINISH	Jamy		Sheet No.	4 from 4		