

EDCON-COMPONENTS



Specifications

Rated Voltage:	3V p-p max. 1/2 duty square wave
Operating Voltage:	1,5~ 4V p-p max. 1/2 duty square wave
Rated Current:	90mA at 3V o-p square wave 1/2 duty square wave
Coil Resistance:	15Ω +/-3Ω
Typical Sound Output:	88B min at 3V o-p square wave 1/2 duty square wave
Operating Frequency:	2731 Hz +/-500Hz
Operating Temperature:	. -30°C to +85°C
Storage Temperature:	. -40°C to +90°C
Termination:	2 soldering pads, Sn plated over Brass
Case Materials:	Plastic LCP
Diaphragm	Ni Alloy Disc N50
Weight	0,6gr.
Life Test	At 3Vp-p in room temperature continuously for 1000hours
High Temperature: Tol.2°C	No function at +90°C for 240hours; function at 85°C for 240hours
Low Temperature: Tol. 2°C	No function at -40°C for 240hours; function at 30°C for 240hours
Humidity:	. +40°C +/-2°C, 95% +/-5% RH, 240hours . -30°C +/-2°C, 0,5hours . +25°C +/-2°C, 0,25hours; . +85°C +/-2°C, 0,5hours
Thermal Shock:	Go up or Drop time is 0,5hr. 3hrs per cycle total is 5 cycles
Vibration:	1,5mm with 10 to 50Hz of vibration frequency to each of 3 perpendicular directions of 2 hours
Shock:	980m/s ² (100g) shock for each mutually perpendicular directions, half sine wave, 3 times each
Drop Test:	Dropped naturally from 750mm height onto the surface of 10mm wooden board. 2 directions upper and side of the parts are appl.
Soldering Heat Resistance:	Samples put through reflowing soldering over 2 times
Solderability:	Samples put on the PCB with solder paste through reflowing soldering oven 1 times for a period of one (1) year from date of manufacture under normal operations.

Features

Reliable Solid State Piezoelectric Technology
Corrosion Resistance Diaphragm
Flame Retardant Plastic
Tape and Reel Packaging for auto mounting

Applications

Automatic Control Equipment
Communication Equipment
Electronic Instruments

Warranty

All specifications must be satisfied after the test (Recovery: 2 to 4 hrs of recovery under the standard condition after the removal from test chamber). 90% min soldering pads shall be with solder (except the edge of pad).

SMD Electro Magnetic Transducer

Part No.: **I14013**

Customer:

DRW:	Jason	CHKD	Wilson	MATL:	Wilson	TOLERANCE	Mason	DATE	10.06.2010
APPD:	Schumi			FINISH	Jamy		Sheet No.		1 from 4

www.edcon-components.com

email: info@edcon-components.com

EDCON-COMPONENTS



Dimensions (mm)

Characteristics

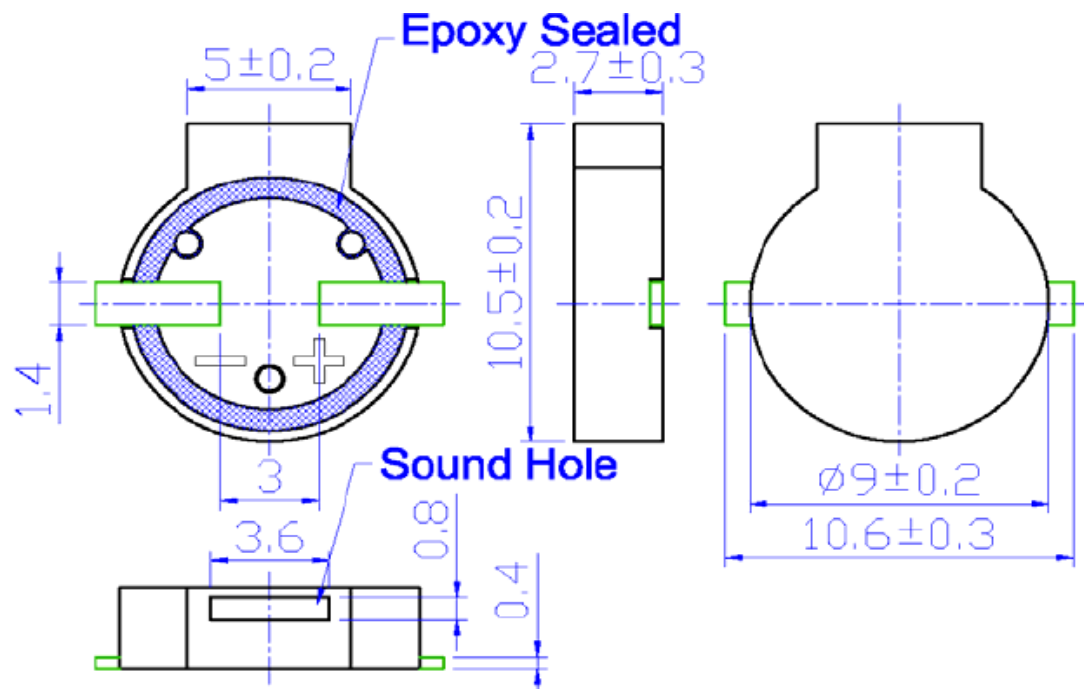

**SMD Electro Magnetic
Tranducer**

Part No.: **I14013**

DRW:	Jason	CHKD	Wilson	MATL:	Wilson	TOLERANCE	Mason	DATE	10.06.2010	Customer:
APPD:	Schumi			FINISH	Jamy		Sheet No.	2 from 4		

www.edcon-components.com

email: info@edcon-components.com

EDCON-COMPONENTS



Ordering Informations

Serie	Model-No.	ROHS	Package						
I14013	09C03152.7F	R	TR						

R = ROHS Conform	TR = Tape Reel
N = NON ROHS Conform	TU = Tube Packing
	TY = Tray Packing

**SMD Electro Magnetic
Tranducer**

Part No.: **I14013**

DRW:	Jason	CHKD	Wilson	MATL:	Wilson	TOLERANCE	Mason	DATE	10.06.2010
APPD:	Schumi			FINISH	Jamy		Sheet No.		3 from 4

Customer:



Soldering Profile Curve

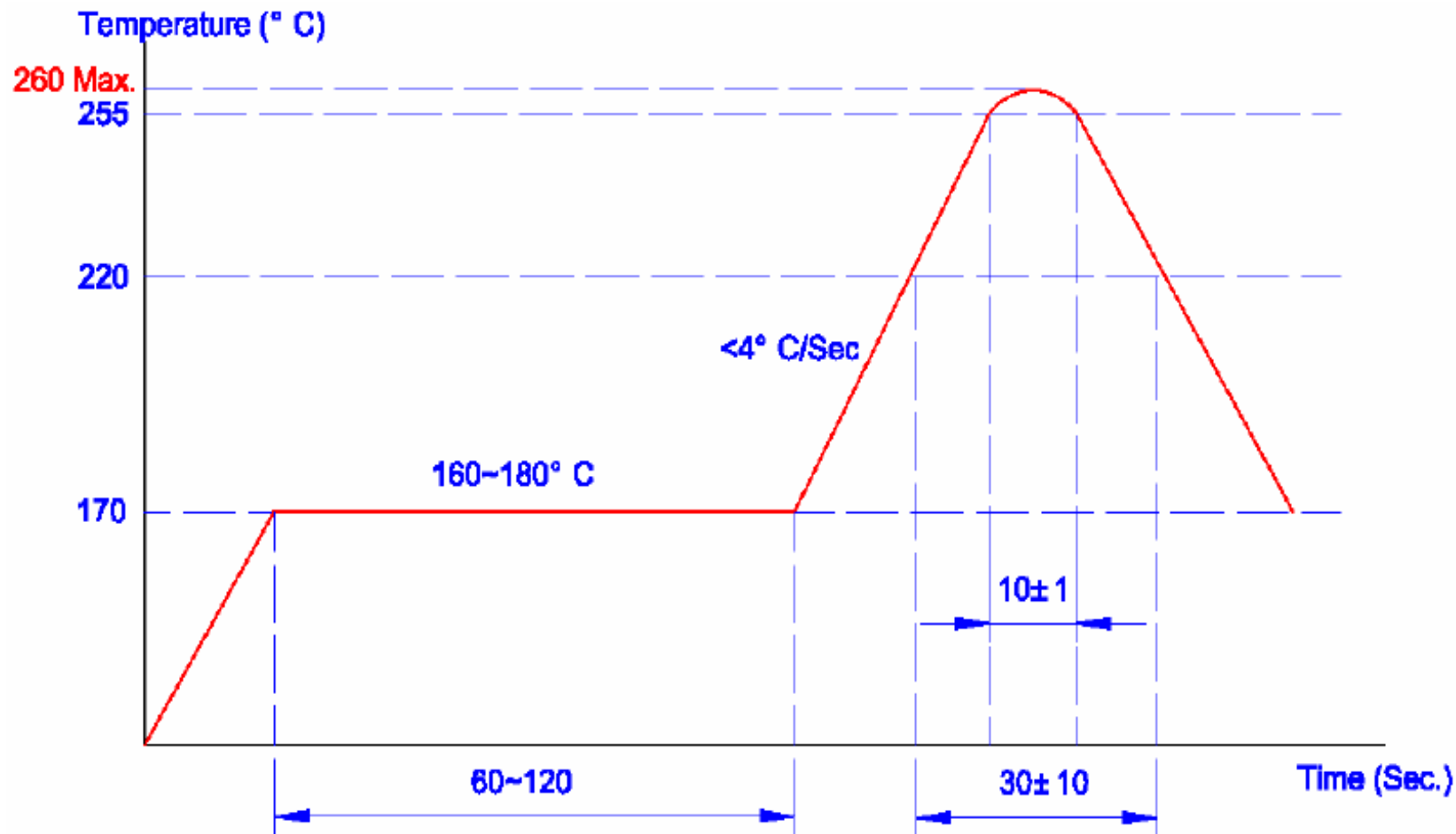

SMD Electro Magnetic Tranducer	
Part No.:	I14013
Customer:	

DRW:	Jason	CHKD	Wilson	MATL:	Wilson	TOLERANCE	Mason	DATE	10.06.2010
APPD:	Schumi			FINISH	Jamy		Sheet No.	4 from 4	