

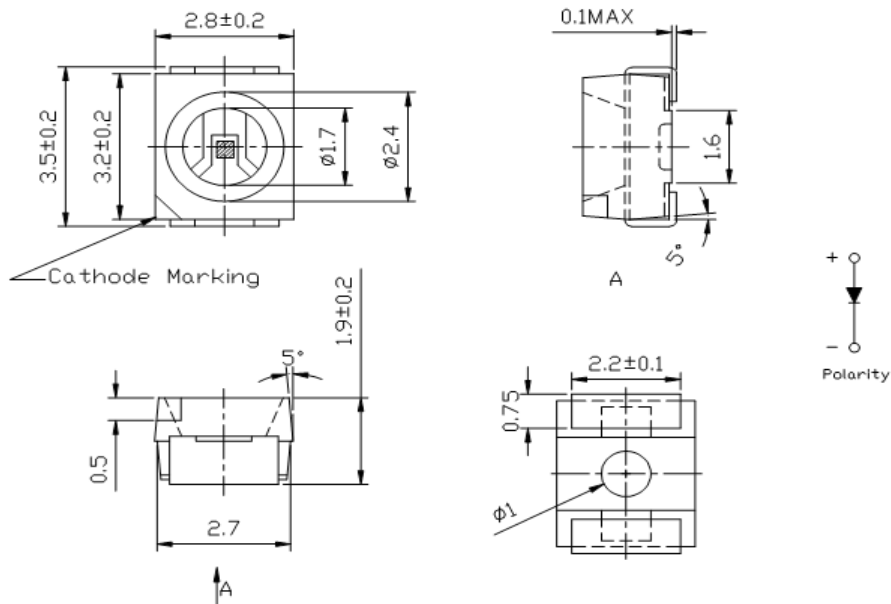

Applications

- Interior automotive lighting
- Optical indicators
- Communication Products
- Backlighting
- Toys

Technical Drawing



Recommended Soldering Pattern

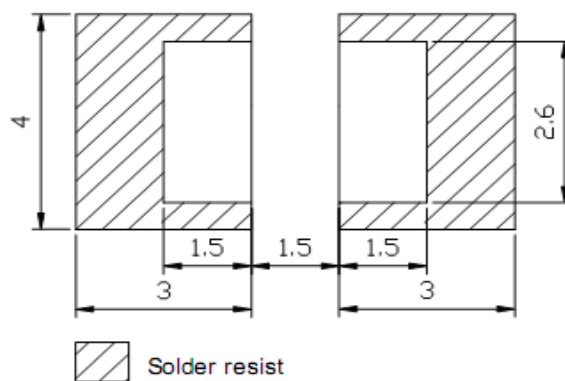

Notes :

All dimensions in mm tolerance is $\pm 0.1\text{mm}$ unless otherwise noted.

| | |
|----------------------|-----------------|
| PLCC2 Red | |
| Part No.: | M11A1288 |
| Customer: | |

| | | | | | | | |
|-------|------|------|-------|--------|------|-------|------------|
| DRW: | Dong | CHKD | Chang | MATL: | Chui | DATE | 27.05.2010 |
| APPD: | Ping | | | FINISH | Hui | Sheet | 1 from 9 |



Absolute Maximum Ratings

Ta=25°C

| <i>Item</i> | <i>Symbol</i> | <i>---</i> | <i>Unit</i> |
|------------------------|-------------------|------------|-------------|
| Power Dissipation | P _D | --- | mW |
| DC Forward Current | I _F | --- | mA |
| Pulsed Forward Current | I _{FP} * | --- | mA |
| Reverse Voltage | V _R | --- | V |
| Operating Temperature | T _{OP} | --- | °C |
| Storage Temperature | T _{ST} | --- | °C |

* 0.1 msec pulse, 10% duty cycle

Electrical / Optical Characteristics

I_F=20mA Ta=25°C

| Emitting Color | Red | | |
|-----------------------------|----------------|-----|----------------|
| Material | --- | | |
| Forward Voltage | typ. | 1.9 | V _F |
| | max. | 2.4 | V _F |
| Wavelength typ. | λ _D | 620 | nm |
| | λ _P | 635 | nm |
| | Δλ | --- | nm |
| Color Temperature | min. | --- | K |
| | max. | --- | K |
| Luminous Intensity * | min. | 300 | mcd |
| | typ. | 450 | mcd |
| Reverse Current | max. | --- | μA |
| Viewing Angle | 2Θ1/2 | 120 | |

* Per NIST standards

| | |
|----------------------------|-----------------|
| PLCC2 Red | |
| Part No.: | M11A1288 |
| Customer: | |

| | | | | | | | |
|-------|------|------|-------|--------|------|-------|------------|
| DRW: | Dong | CHKD | Chang | MATL: | Chui | DATE | 27.05.2010 |
| APPD: | Ping | | | FINISH | Hui | Sheet | 2 from 9 |



Directive Characteristics

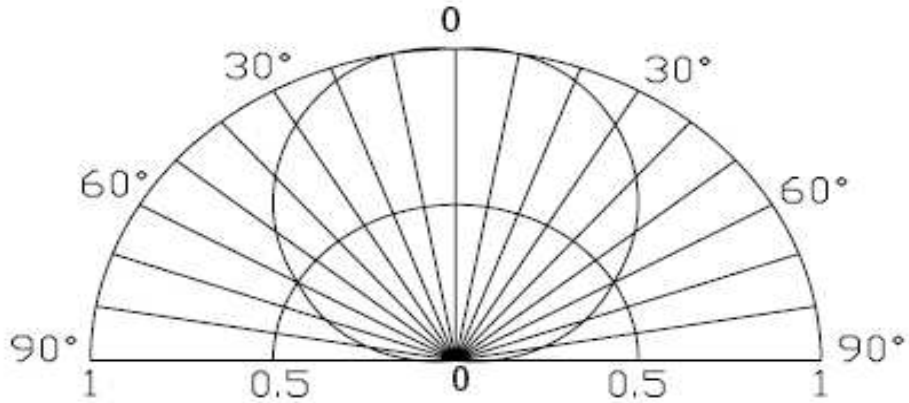

| | |
|----------------------------|-----------------|
| PLCC2 Red | |
| Part No.: | M11A1288 |
| Customer: | |

| | | | | | | | |
|-------|------|------|-------|--------|------|-------|------------|
| DRW: | Dong | CHKD | Chang | MATL: | Chui | DATE | 27.05.2010 |
| APPD: | Ping | | | FINISH | Hui | Sheet | 3 from 9 |



| | |
|----------------------|-----------------|
| PLCC2 Red | |
| Part No.: | M11A1288 |
| Customer: | |

| | | | | | | | |
|-------|------|------|-------|--------|------|-------|------------|
| DRW: | Dong | CHKD | Chang | MATL: | Chui | DATE | 27.05.2010 |
| APPD: | Ping | | | FINISH | Hui | Sheet | 4 from 9 |



Solder Condition

Lead Free Solder



| | |
|----------------------------|-----------------|
| PLCC2 Red | |
| Part No.: | M11A1288 |
| Customer: | |

| | | | | | | | |
|-------|------|------|-------|--------|------|-------|------------|
| DRW: | Dong | CHKD | Chang | MATL: | Chui | DATE | 27.05.2010 |
| APPD: | Ping | | | FINISH | Hui | Sheet | 5 from 9 |



Packing Specifications

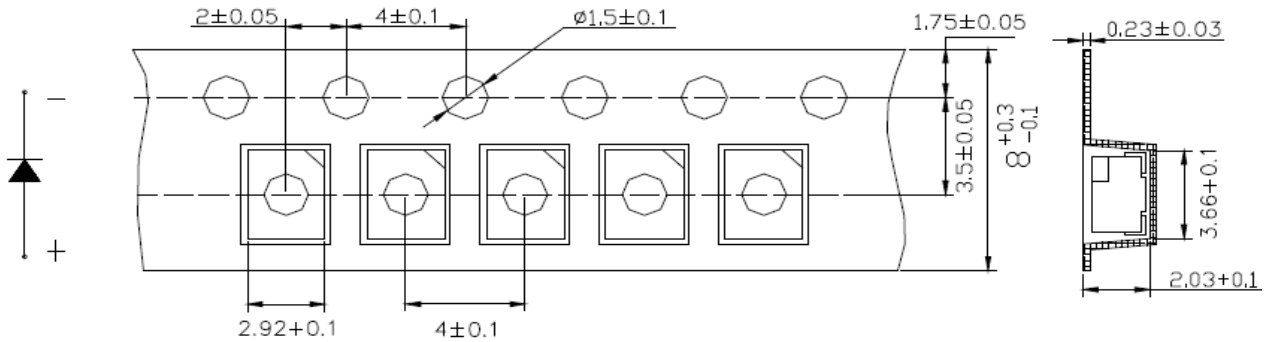

Reel Specifications

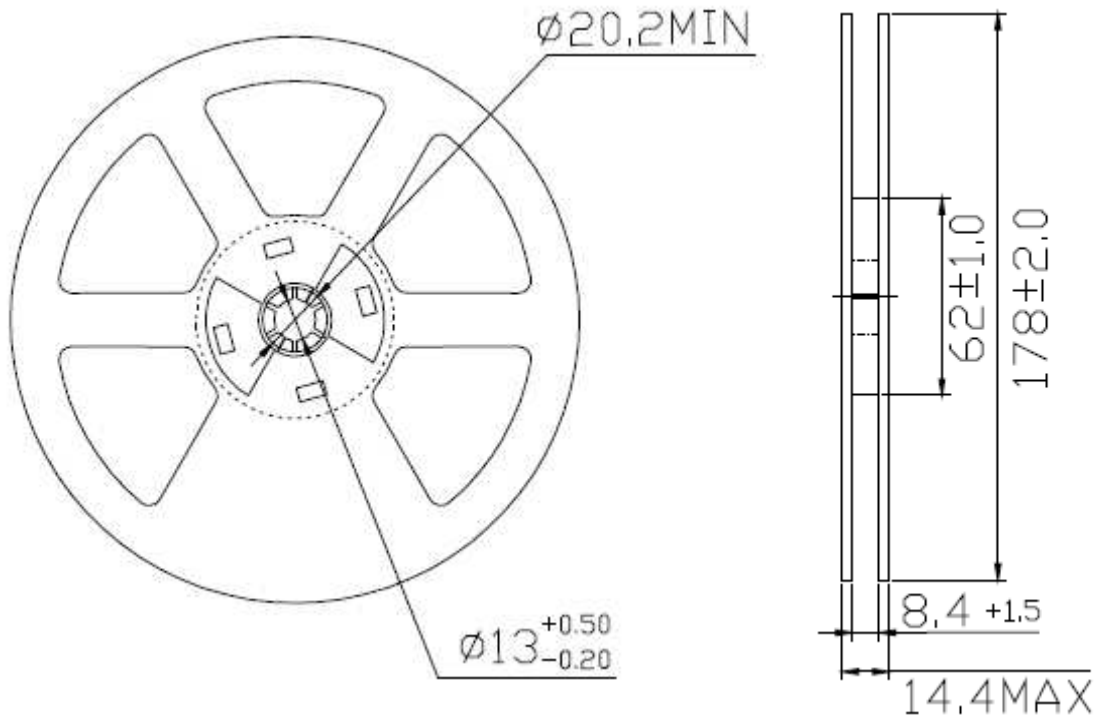

PLCC2
Red

Part No.: **M11A1288**

Customer:

| | | | | | | | |
|-------|------|------|-------|--------|------|-------|------------|
| DRW: | Dong | CHKD | Chang | MATL: | Chui | DATE | 27.05.2010 |
| APPD: | Ping | | | FINISH | Hui | Sheet | 6 from 9 |



Handling Precautions

Compare to epoxy encapsulant that is hard and brittle, silicone is softer and flexible. Although its characteristic significantly reduces thermal stress, it is more susceptible to damage by external mechanical force. As a result, special handling precautions need to be observed during assembly using silicone encapsulated LED products. Failure to comply might lead to damage and premature failure of the LED.

1. Handle the component along the side surfaces by using forceps or appropriate tools



2. Do not directly touch or handle the silicone lens surface. It may damage the internal circuitry.

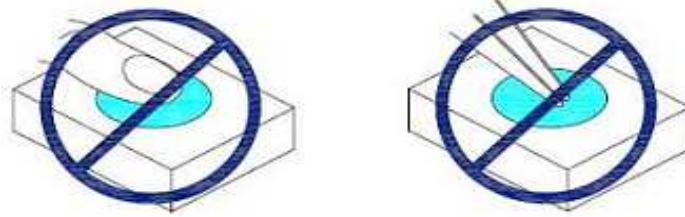

3. Do not stack together assembled PCBs containing exposed LEDs. Outside impact may scratch the silicone lens or damage the internal circuitry.



PLCC2
Red

Part No.: **M11A1288**

Customer:

| | | | | | | | |
|-------|------|------|-------|--------|------|-------|------------|
| DRW: | Dong | CHKD | Chang | MATL: | Chui | DATE | 27.05.2010 |
| APPD: | Ping | | | FINISH | Hui | Sheet | 7 from 9 |



- The outer diameter of the TOP LED pickup nozzle should not exceed the size of the LED to prevent air leaks. The inner diameter of the nozzle should be as large as possible.
- A pliable material is suggested for the nozzle tip to avoid scratching or damaging the LED surface during pickup.
- The dimensions of the component must be accurately programmed in the pick-and-place machine to insure precise pickup and avoid damage during production.



| | | | | | | | |
|----------------------|--|--|--|--|--|-----------------|--|
| PLCC2 Red | | | | | | | |
| Part No.: | | | | | | M11A1288 | |
| Customer: | | | | | | | |

| | | | | | | | |
|-------|------|------|-------|--------|------|-------|------------|
| DRW: | Dong | CHKD | Chang | MATL: | Chui | DATE | 27.05.2010 |
| APPD: | Ping | | | FINISH | Hui | Sheet | 8 from 9 |



Color table curve

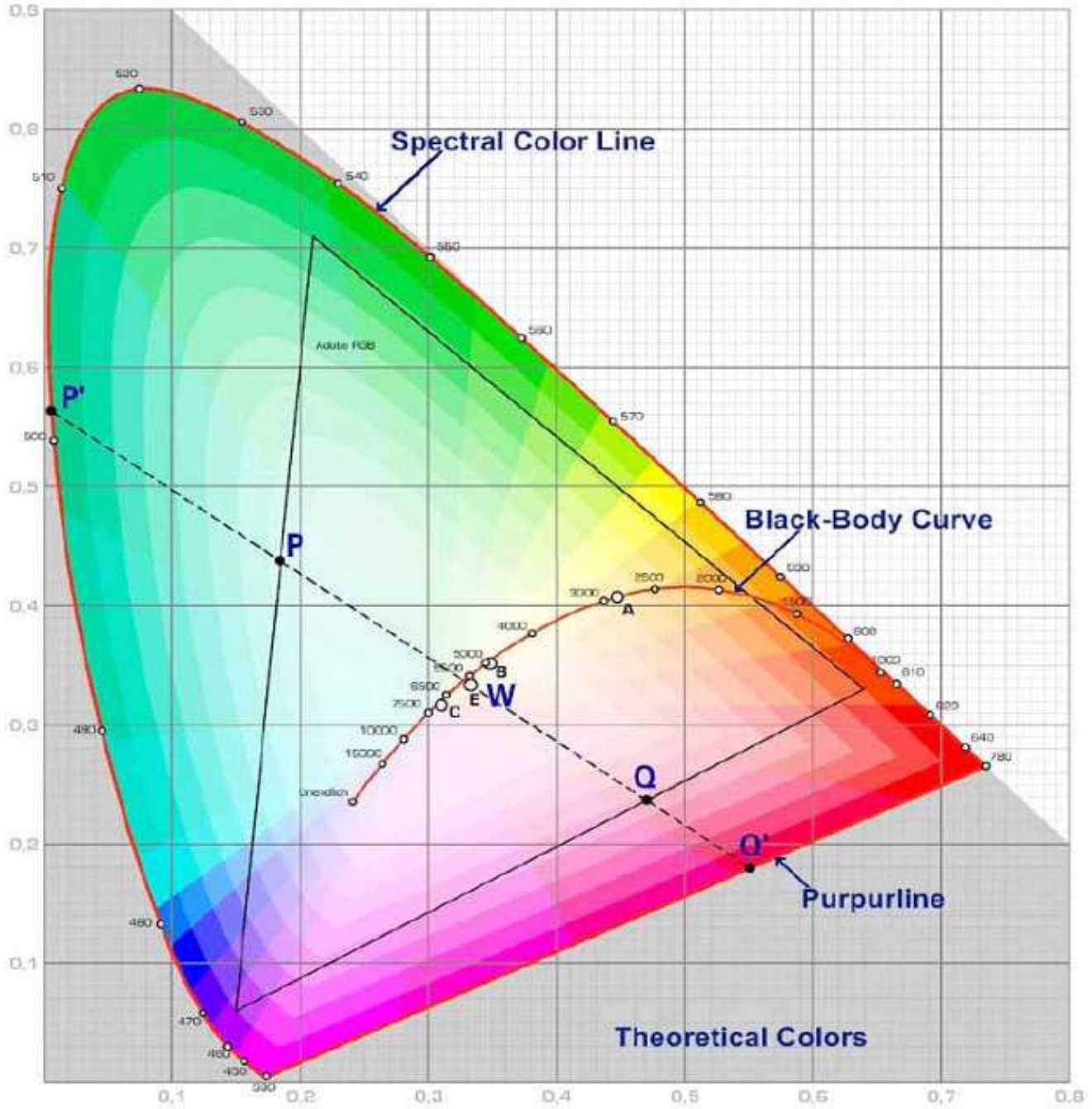

| | |
|----------------------------|-----------------|
| PLCC2 Red | |
| Part No.: | M11A1288 |
| Customer: | |

| | | | | | | | |
|-------|------|------|-------|--------|------|-------|------------|
| DRW: | Dong | CHKD | Chang | MATL: | Chui | DATE | 27.05.2010 |
| APPD: | Ping | | | FINISH | Hui | Sheet | 9 from 9 |

Copyright by EDCON-COMPONENTS